

FT-980

TECHNICAL SUPPLEMENT

YAESU MUSEN CO., LTD.

C.P.O. BOX 1500
TOKYO, JAPAN

CONTENTS

	(Page)
ERRATA FOR THE FT-980 OPERATING MANUAL	2
SOLDERING AND DESOLDERING TECHNIQUE	4
GENERAL PERFORMANCE IMPROVEMENT MODIFICATIONS	7
CAT SYSTEM SERIAL I/O DATA MANUAL	13
UNIT LOCATIONS	18
SERVICE AND ALIGNMENT	20
COMPONENT APPLICATIONS	32
FREQUENCY RELATIONSHIPS	49
SIGNAL PATHS	50
CPU BOARD BLOCK DIAGRAM	54
CONNECTION DIAGRAM	55
PARTS LAYOUTS, SCHEMATICS, SIGNAL LEVELS AND VOLTAGE CHARTS	
RF UNIT	56
IF UNIT	60
AF UNIT	63
VFO UNIT	66
PLL AND VCO UNITS	69
CPU UNIT	74
FSK UNIT	77
LPF AND RELAY UNITS	79
PROTECTOR UNIT	80
DIAL UNIT	81
REG UNIT	83
CONTROL UNIT	85
KEY MATRIX UNIT	86
DISPLAY UNITS (A, B and C)	87
MONITOR UNIT	90
100W PA UNIT	91
10W PA UNIT	92
100W PS UNIT	93
10W PS UNIT	94
PI UNIT	95
MISCELLANEOUS UNITS	96
FIF-80 INTERFACE UNIT	97
FRONT PANEL EXPLODED VIEW	98
REAR PANEL EXPLODED VIEWS	99
PARTS LIST	100

FT-980

TECHNICAL SUPPLEMENT



This manual is intended to serve as a technical supplement to the FT-980 Operating Manual. Detailed information regarding functions, installation, interconnections, operation, and installation of options has been provided in the Operating Manual, and is not reprinted herein. Therefore, this Technical Supplement is not intended to serve as an independent reference, but to be used in conjunction with the information provided in the Operating Manual.

Because there are nearly eight hundred semiconductor devices in the FT-980, circuit description information is provided in the form of numerous block diagrams and a complete Component Applications list. It is our hope that this manner of providing functional information will prove to be more convenient for the owner and technician than would a lengthy verbal description. Those readers who are not familiar with the basic types of analog and digital circuits that serve as the building blocks of the FT-980 are encouraged to study instructional material, such as that contained in handbooks on amateur radio and digital circuit design, before attempting to understand the design of the FT-980. Each block in the block diagrams represents one such basic circuit, while the Component Applications list provides additional details for each semiconductor. Specific circuit details are provided in the schematic diagrams.

The few modifications that have been developed for the FT-980 since the start of production are all included in this Manual. All of the general performance improvement modifications have been incorporated from Production Lot 3 onwards, while some have been incorporated in some transceivers in earlier Lots (1 and 2).

While we believe this technical information is correct and factual, Yaesu assumes no liability for damage that may result from typographical or other errors that may be present. Your cooperation in pointing out any inconsistencies in the technical information would be appreciated.

Yaesu Musen reserves the right to make changes in the circuitry of this transceiver, in the interest of technological improvement, without notification of the owner.

ERRATA FOR THE FT-980 OPERATING MANUAL

The following corrections and additions apply to the first printing of the FT-980 Operating Manual:

Page 20

Later printings of the Operating Manual include important notes related to the interconnection of linear amplifiers. Page 3 of this Technical Supplement is a replacement for page 20 of the first printing of the Operating Manual.

Page 21

The note beneath the drawing of the ACC-2 plug wiring should be replaced with the following:

“(Do not jumper from pin 4 to GND)”

Page 22

In diagram 2, showing the signal flow through the IF filters with only the optional CW-W filter (XF-8.9HC) installed in position XF₂₀₀₆, the label on the arrow pointing into the CW-W filter should say “CW-N”, and not “CW-W”. The CW-W signal passes through SSB filter position XF₂₀₀₅.

Page 33

The following paragraph is added to step 3:

If the XF-455.8MCN CW-N filter is not being installed, and is not installed already, locate plug P₇₁ (on J₂₀₀₁), and reverse the wires in locations 3 and 4, so that the white/orange wire ends up at pin 3, and white/red at pin 4.

Also, the next paragraph is added to step 5:

Check the colors of the wires at pins 3 and 4 of P₇₁ (on J₂₀₀₁). Make sure that the white/red wire is at pin 3, and the white/orange wire is at pin 4. If not, reverse the connectors at these pins.

and the drawing at the right is added to the page, showing the method of removing the wire connectors from P₇₁.

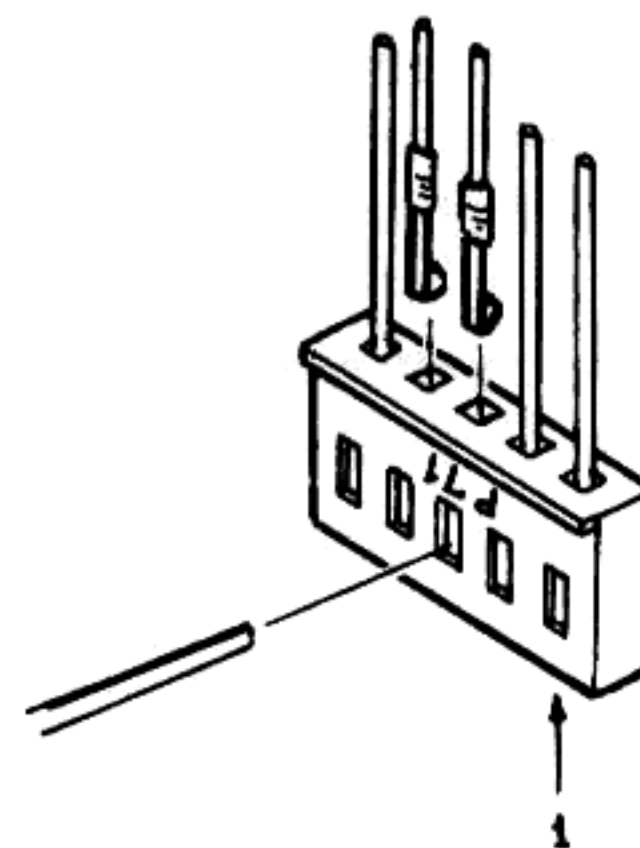

LINEAR AMPLIFIER INTERCONNECTIONS

When a linear amplifier is used with the FT-980, check the current required to control the T/R relay in the linear amplifier. If less than 200 mA, the T/R control line can be directly connected to TX GND and GND on ACC-2 jack. However, also be sure that a back pulse cancelling diode is installed across the T/R relay in your linear amplifier. If this diode is not present, install a general purpose rectifier diode as shown in Figure 1.

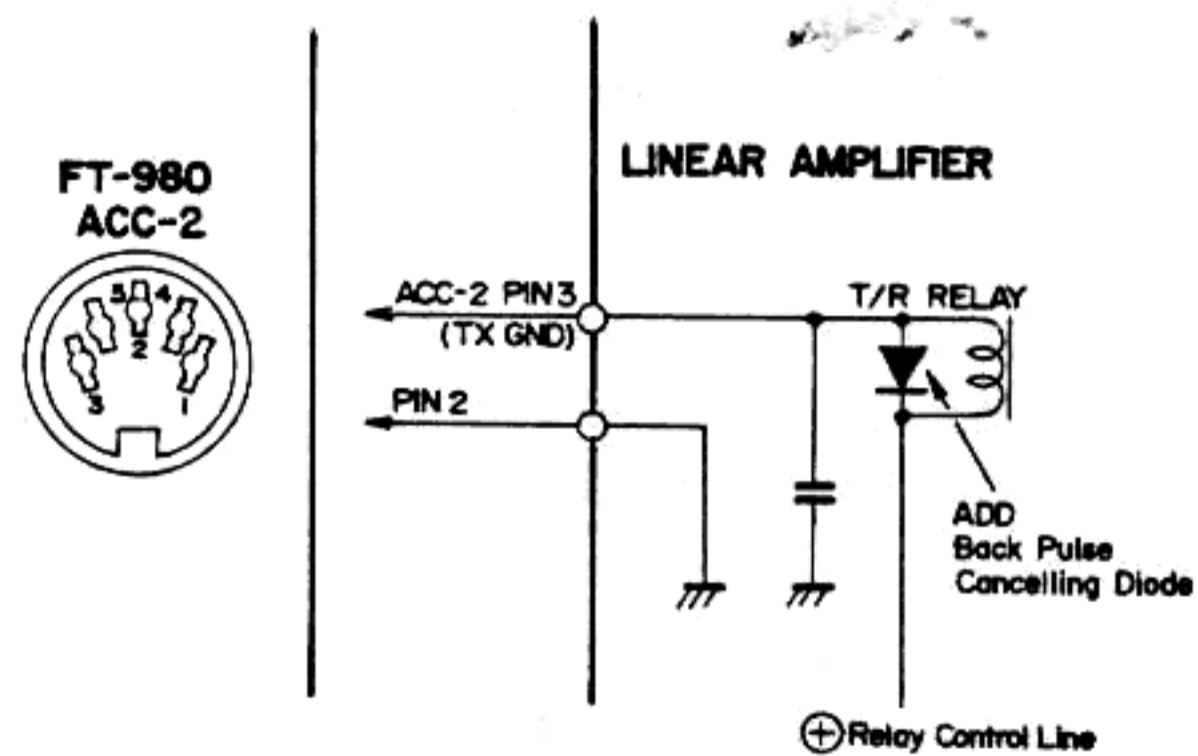

Figure 1

When the required T/R relay current is higher than 200 mA, the T/R control line from the linear amplifier must not be connected directly to the ACC-2 jack, but an extra relay box must be used to avoid damage to the T/R relay in the FT-980. Refer to Figure 2, and make the relay box for the interconnection. This relay box is not available from Yaesu.

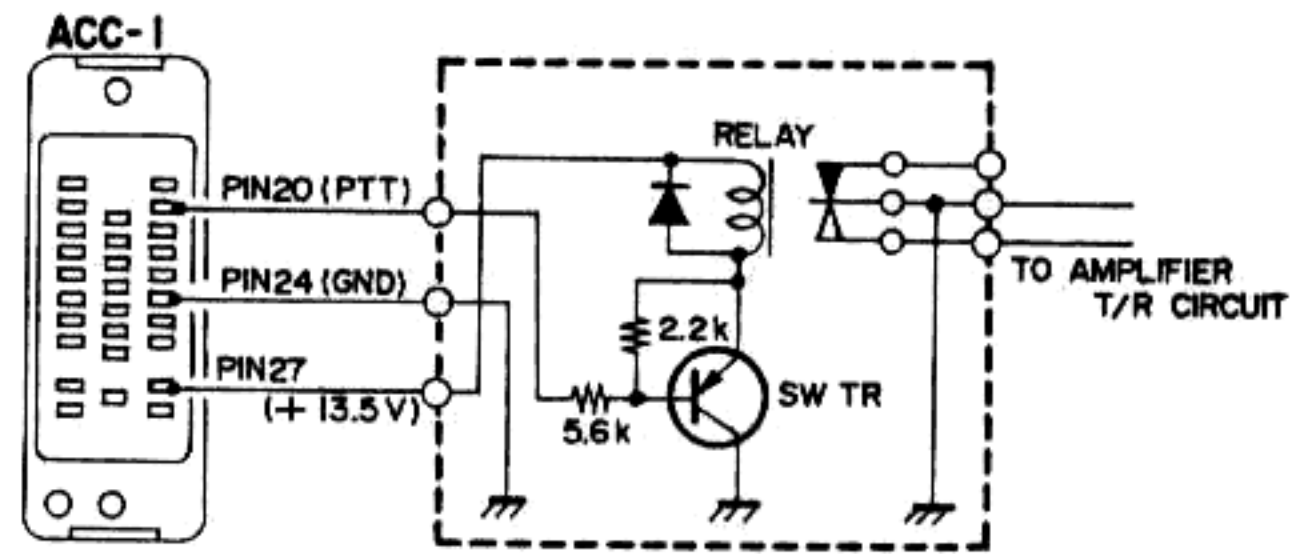
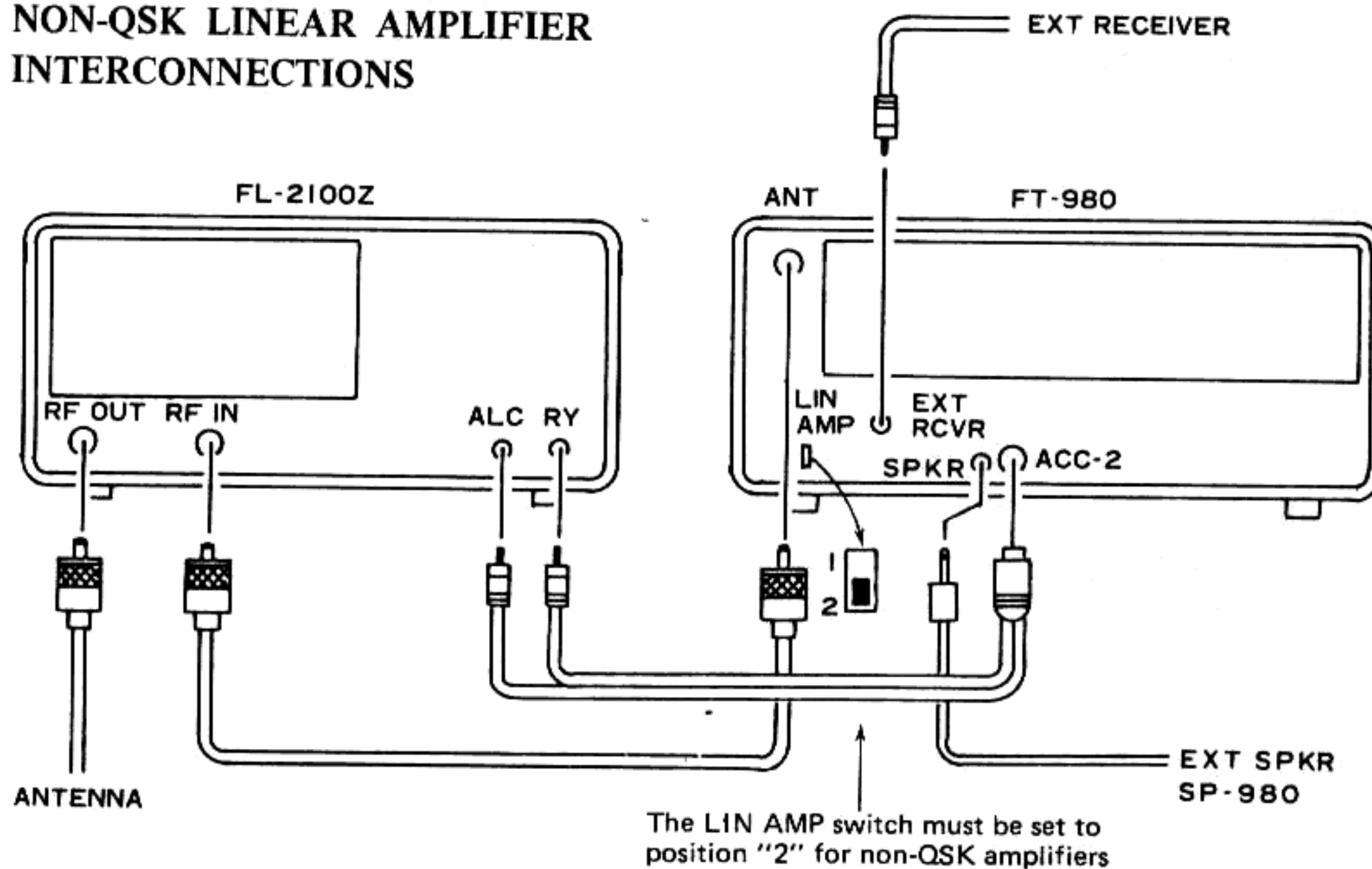
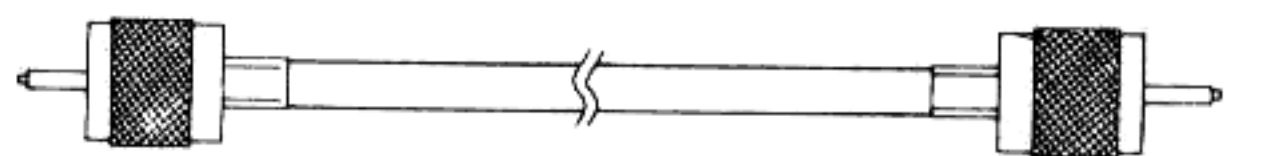

Figure 2

NON-QSK LINEAR AMPLIFIER INTERCONNECTIONS



FL-2100Z }
FC-102 }
FC-902 }



FT-980(ANT)

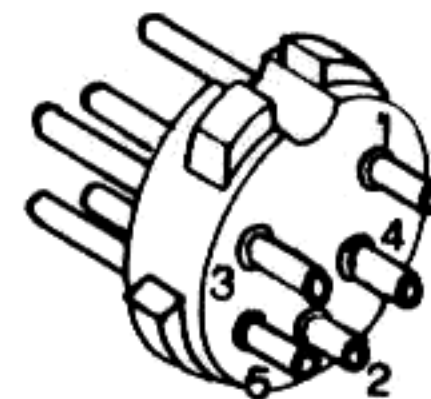

- 1 EXT ALC
- 2 GND
- 3 TX GND
- 4 DELAY
- 5 RX GND

If the closing time of the T/R relay in the linear amplifier is long enough to cause the ALC of the FT-980 to pulse at the start of transmission, install a jumper between pins 4 and 2 of this plug. If in doubt, install the jumper.

Please read the caution notice on page 32.

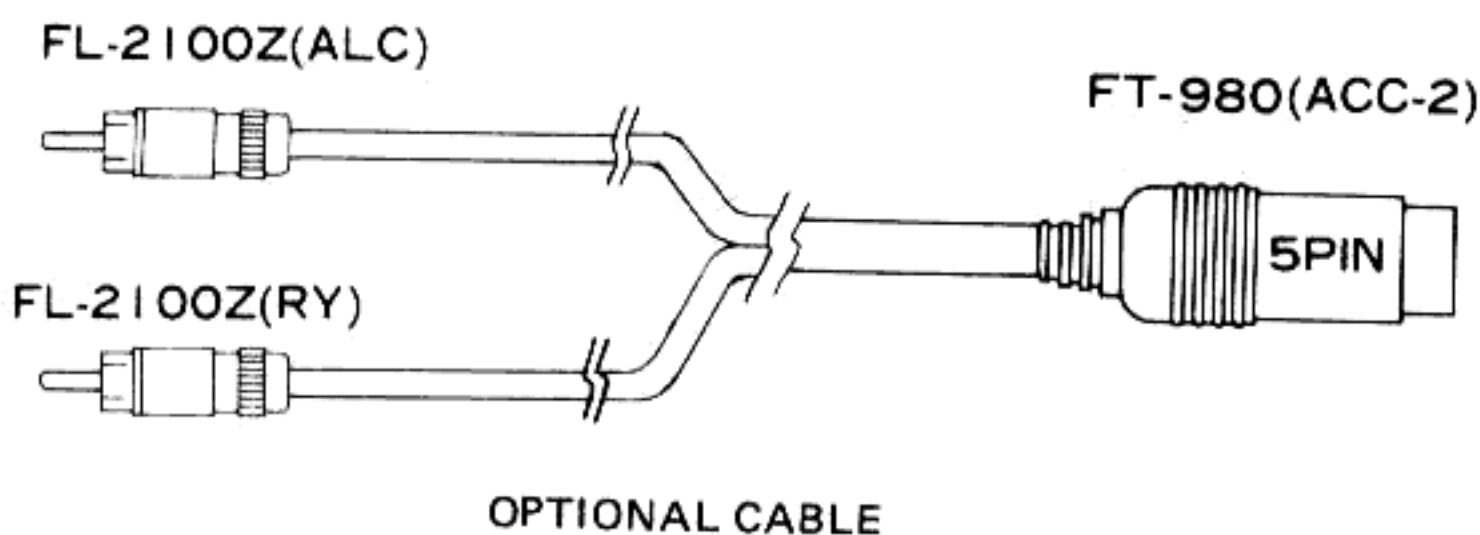

OPTIONAL CABLE

ACC-2 Plug Connections

SOLDERING AND DESOLDERING TECHNIQUE

SOLDERING AND DESOLDERING TECHNIQUE ON PRINTED CIRCUIT BOARDS

The FT-980 circuit boards are tough, but mishandling during soldering can cause circuit traces to "lift." While this does not cause permanent damage to the board, much servicing trouble can result, because of the tendency for this lifted trace to break. A few simple precautions will keep your circuit boards in A-1 condition.

1. Use only a 12 to 30-watt chisel-tip soldering iron, with the tip rounded or isolated from AC and DC potential. Voltage at the tip can easily destroy CMOS components.
2. Use only the minimum amount of heat necessary to remove a component, or to cause the solder to "flow" when installing a new component.
3. USE ONLY 60/40 ROSIN CORE SOLDER.
4. Use solder removing braid and flux to absorb excess solder before installing a new component. A solder sucker can also be used, but must be handled with care to avoid lifting traces.
5. Do not attempt to remove DIP ICs without first cutting all of the pins on the component side of the board, unless you have the correct desoldering equipment (spring-loaded clamp and all-pin desoldering tip).

If you do lift a trace, don't worry! Read on to find out how to repair traces like a pro.

NOTES ON USE OF CMOS COMPONENTS:

As CMOS devices are extremely sensitive to damage from static electricity, special precautions must be observed.

In storage, use only conductive sponge specially designed for CMOS components.

When installing a CMOS part in a socket, or on a circuit board, be certain that the power is off. In addition, the technician should rest his hand on the chassis as the component is inserted, so as to place his hand at the same potential as the chassis (better to discharge small amounts of static electricity through your fingers than through a \$5 IC!).

When soldering a CMOS part onto a circuit board, use a low-wattage iron, and be sure to ground the tip with a clip lead, if the tip is not grounded through a three-wire power cord.

INSERTION OF PARTS ON CIRCUIT BOARDS

All of the below are acceptable ways of inserting components into circuit board mounting holes.



(a) Bend leads slightly

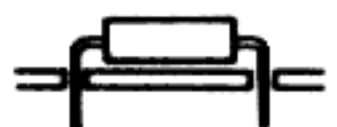

(b) Straight-in mounting

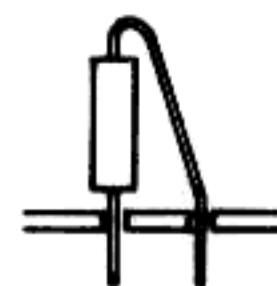

(c) Vertical mounting

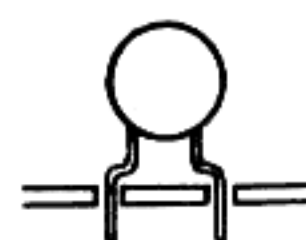

(d) Preformed disc ceramic capacitor



(e) Preformed resistor, diode, etc.

SOLDERING AND DESOLDERING TECHNIQUE

SOLDERING AND DESOLDERING TECHNIQUE ON PRINTED CIRCUIT BOARDS

The FT-980 circuit boards are tough, but mishandling during soldering can cause circuit traces to "lift." While this does not cause permanent damage to the board, much servicing trouble can result, because of the tendency for this lifted trace to break. A few simple precautions will keep your circuit boards in A-1 condition.

1. Use only a 12 to 30-watt chisel-tip soldering iron, with the tip rounded or isolated from AC and DC potential. Voltage at the tip can easily destroy CMOS components.
2. Use only the minimum amount of heat necessary to remove a component, or to cause the solder to "flow" when installing a new component.
3. USE ONLY 60/40 ROSIN CORE SOLDER.
4. Use solder removing braid and flux to absorb excess solder before installing a new component. A solder sucker can also be used, but most be handled with care to avoid lifting traces.
5. Do not attempt to remove DIP ICs without first cutting all of the pins on the component side of the board, unless you have the correct desoldering equipment (spring-loaded clamp and all-pin desoldering tip).

If you do lift a trace, don't worry! Read on to find out how to repair traces like a pro.

NOTES ON USE OF CMOS COMPONENTS:

As CMOS devices are extremely sensitive to damage from static electricity, special precautions must be observed.

In storage, use only conductive sponge specially designed for CMOS components.

When installing a CMOS part in a socket, or on a circuit board, be certain that the power is off. In addition, the technician should rest his hand on the chassis as the component is inserted, so as to place his hand at the same potential as the chassis (better to discharge small amounts of static electricity through your fingers than through a \$5 IC!).

When soldering a CMOS part onto a circuit board, use a low-wattage iron, and be sure to ground the tip with a clip lead, if the tip is not grounded through a three-wire power cord.

INSERTION OF PARTS ON CIRCUIT BOARDS

All of the below are acceptable ways of inserting components into circuit board mounting holes.

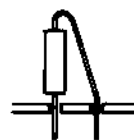
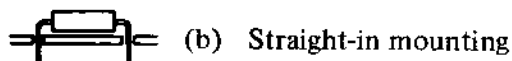
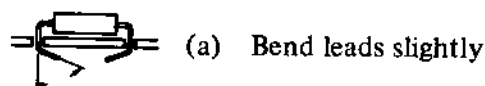

(c) Vertical mounting

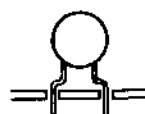

(d) Preformed disc ceramic capacitor



(e) Preformed resistor, diode, etc.

BASIC SOLDERING PRACTICE

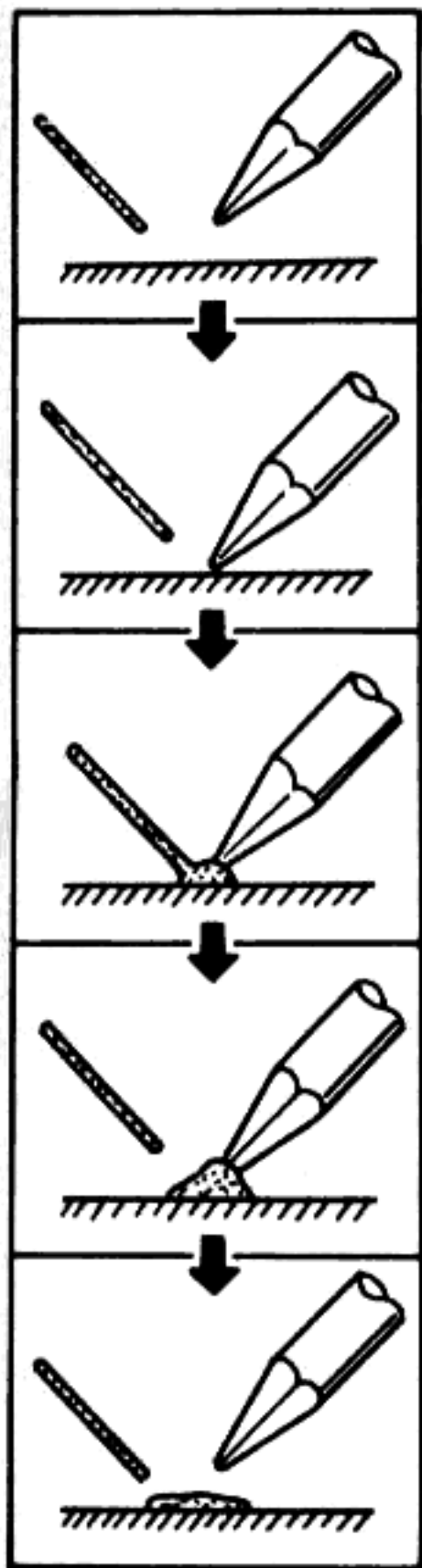

- (1) Prepare soldering iron and solder. The tip of the iron should be thoroughly tinned and wiped clean of excess solder.
- (2) Apply soldering iron to surface to be soldered. Do not press the iron into the surface.
- (3) Apply solder to junction of iron and heated surface.
- (4) When enough solder is applied, remove solder. Continue to apply heat just until solder flows cleanly.
- (5) Remove iron from work. Do not apply more heat than necessary for good solder flow.

Soldering to terminal posts:

(Be certain to apply heat to both post and wire.)

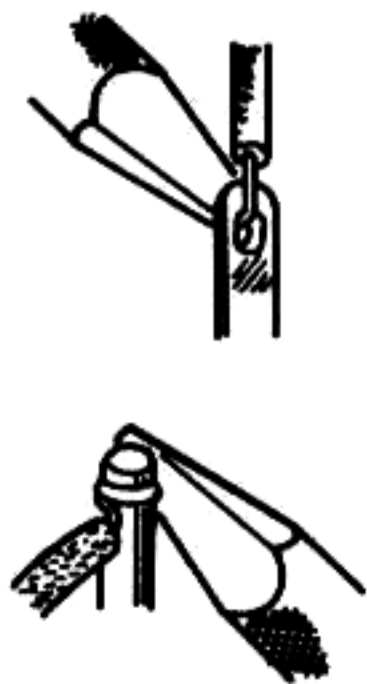
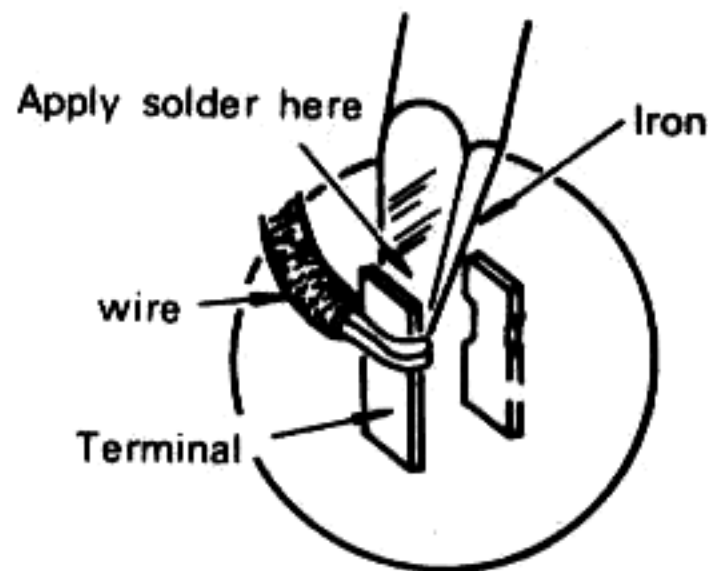

EXAMPLES OF POOR SOLDERING PRACTICE

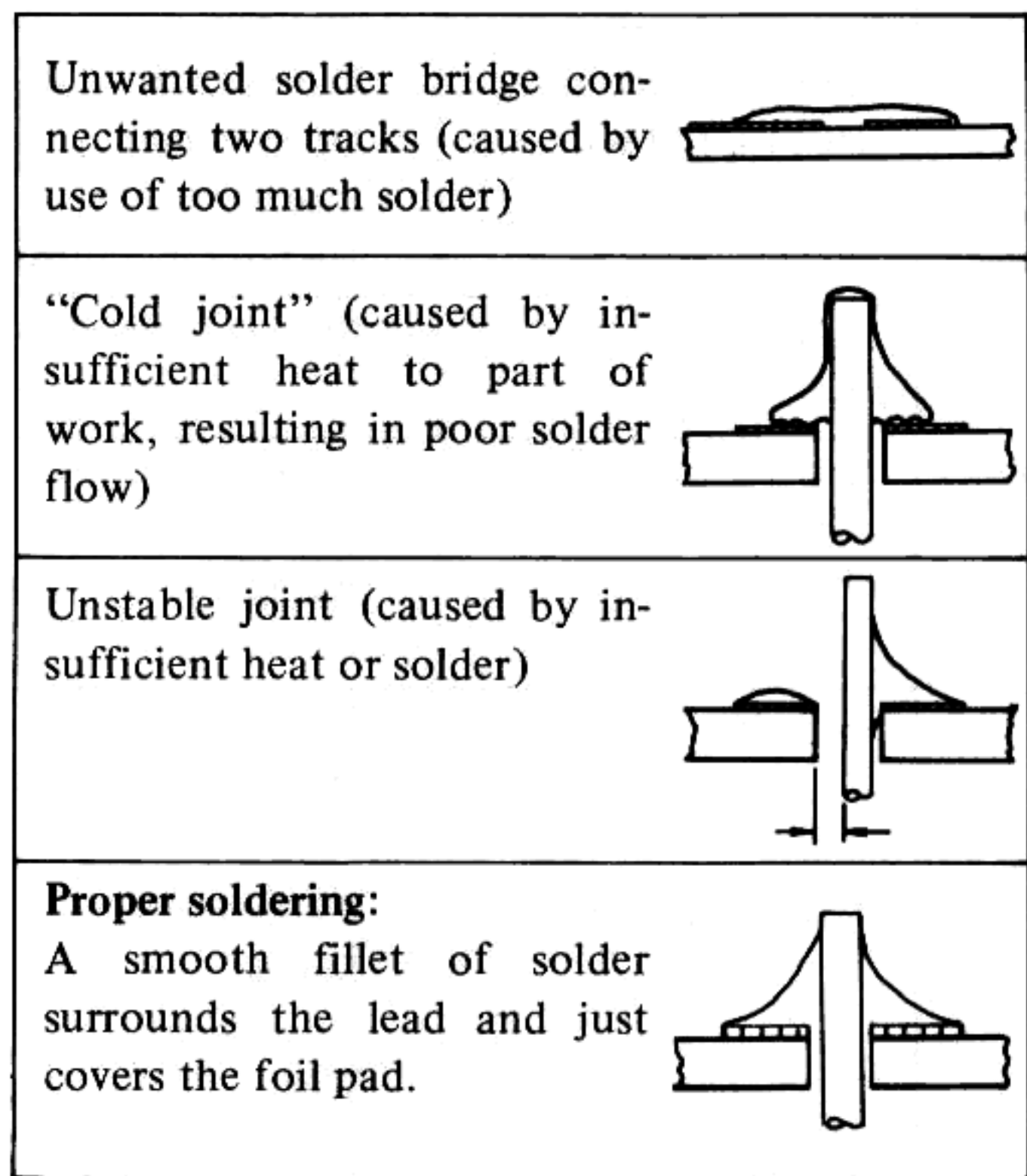

If you have previously lifted a trace, make an etch cut on each side of the lifted trace as shown in the drawing, and install a wire bridge.

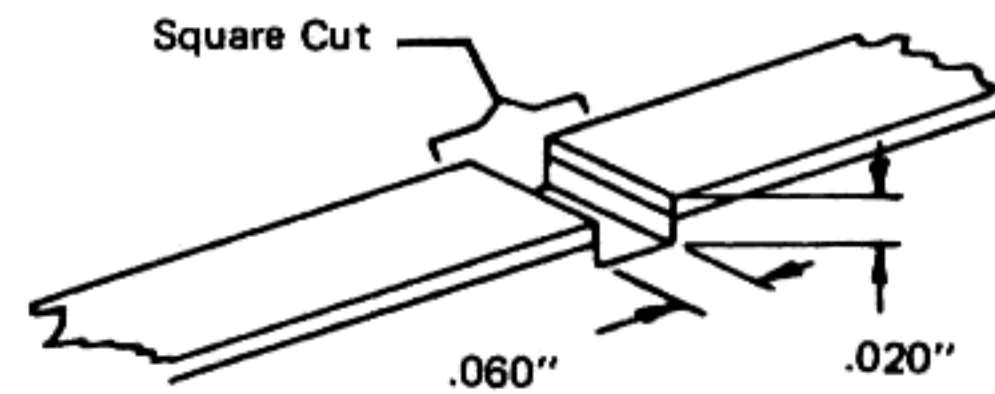
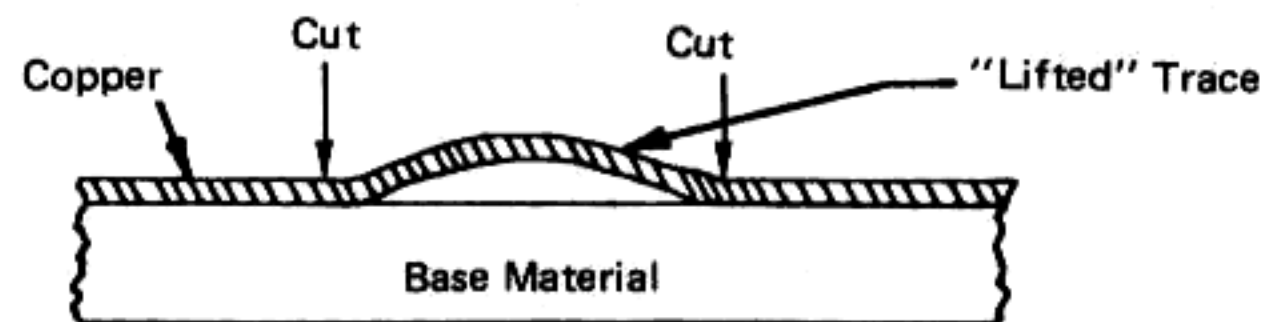

Coat Cut Area With Eastman 910
After Soldering Wire Bridge

TYPICAL PART FAILURES, CAUSES AND SYMPTOMS

PARTS	CAUSE OF TROUBLE	SYMPTOMS
Semiconductors (IC, FET, TR)	High supply voltage Open circuit Excessive drive High temperature	Short or open circuit Output decreases to 1/2 at 80°C Internal noise Instability
MOS FET MOS IC	Static electricity	Total failure Short or open circuit
Crystal Crystal filter	Shock High temperature Aging	No oscillation Off frequency Frequency drift Filter bandpass change
Resistor	Excessive power High temperature	Component burned Value changed Open circuit
Potentiometer	Excessive power Shock Dust or oil Wear	Component burned Open circuit Noise Unsmooth rotation
Capacitor	Excess voltage High temperature Aging	Shorted Leakage Open/decreased capacitance
Variable capacitor Trimmer capacitor	Ratings exceeded Dust between plates Shock, forced rotation	Shorted Leakage Unsmooth rotation
Coils	Ratings exceeded Misadjusted Core or bobbin broken	Open or short circuit Leakage or shorted turns Detuned
Switch	Ratings exceeded Aging Dust or oil	Poor contact Unsmooth operation Open circuit
Relay	Ratings exceeded Humidity Dust or oil on contacts	Coil open Poor or intermittent contact Noise

GENERAL PERFORMANCE IMPROVEMENT MODIFICATIONS

This set of simple modifications improves a number of performance aspects of the FT-980. Some of these have already been carried out in some early models, but all have been done on transceivers having serial numbers above XX030000 (Lot 3).

Serial numbers are composed of a letter and a number, indicating the date of manufacture, followed by six digits. The first two digits (closest to the date code) are the Production Lot number. So, for example, serial number 0C123456 is from Production Lot 12, set number 3456. Before making any modification, make sure that the procedure to be followed applies to the Lot number of the particular transceiver being modified.

Also, before making any modification, check to see if the intended modification has already been carried out by a Yaesu agent, dealer or previous owner.

The component changes are summarized below, and actual details of the modifications are given pictorially on the following pages.

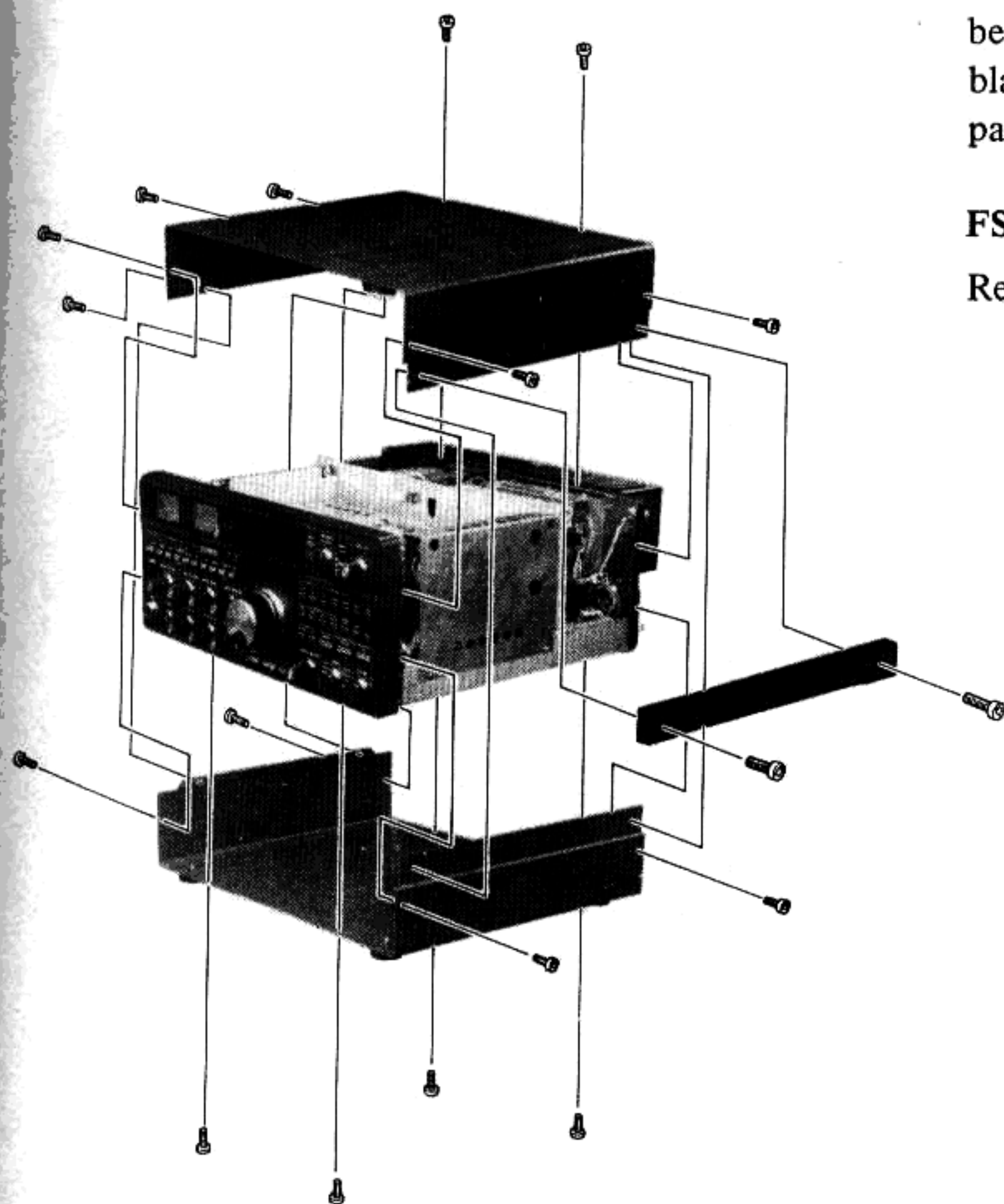

RF Unit (page 8)

Add type 1SS53 (general purpose silicon) diode D_{1096} between the common anodes of the diodes connected to J_{1016} and pin 10 of Q_{1028} . The cathode of the new diode connects to Q_{1028} . Install on the solder side of the board, and use plastic insulating sleeves on each lead of the diode.

PLL/VCO Unit (page 9)

Remove resistors R_{7067} and R_{7093} . On the solder side of the board, cut the indicated track on the copper pattern in the area between Q_{4011} and Q_{4013} , and install the two jumpers as indicated in the figures on page 10.

VFO Unit (page 11)

Remove resistors R_{4036} , R_{4037} and R_{4038} , capacitor C_{4042} , and diode D_{4002} . Replace R_{4036} with 1.5 kilohms in the same location as the original part. Replace R_{4037} with 100 kilohms, but install one lead in the hole originally used for the nearest lead of C_{4042} (removed), as illustrated.

In the VCO enclosure on the VFO Unit, remove capacitors C_{4009} and C_{4011} , and replace both with the same value CH-type (instead of RH and UJ, removed). Make sure that these have not already been changed before removing: the CH types have black paint on the top, or are marked "CH". See page 12.

FSK Unit

Remove capacitor C_{1802} , shown on page 12.

RF UNIT

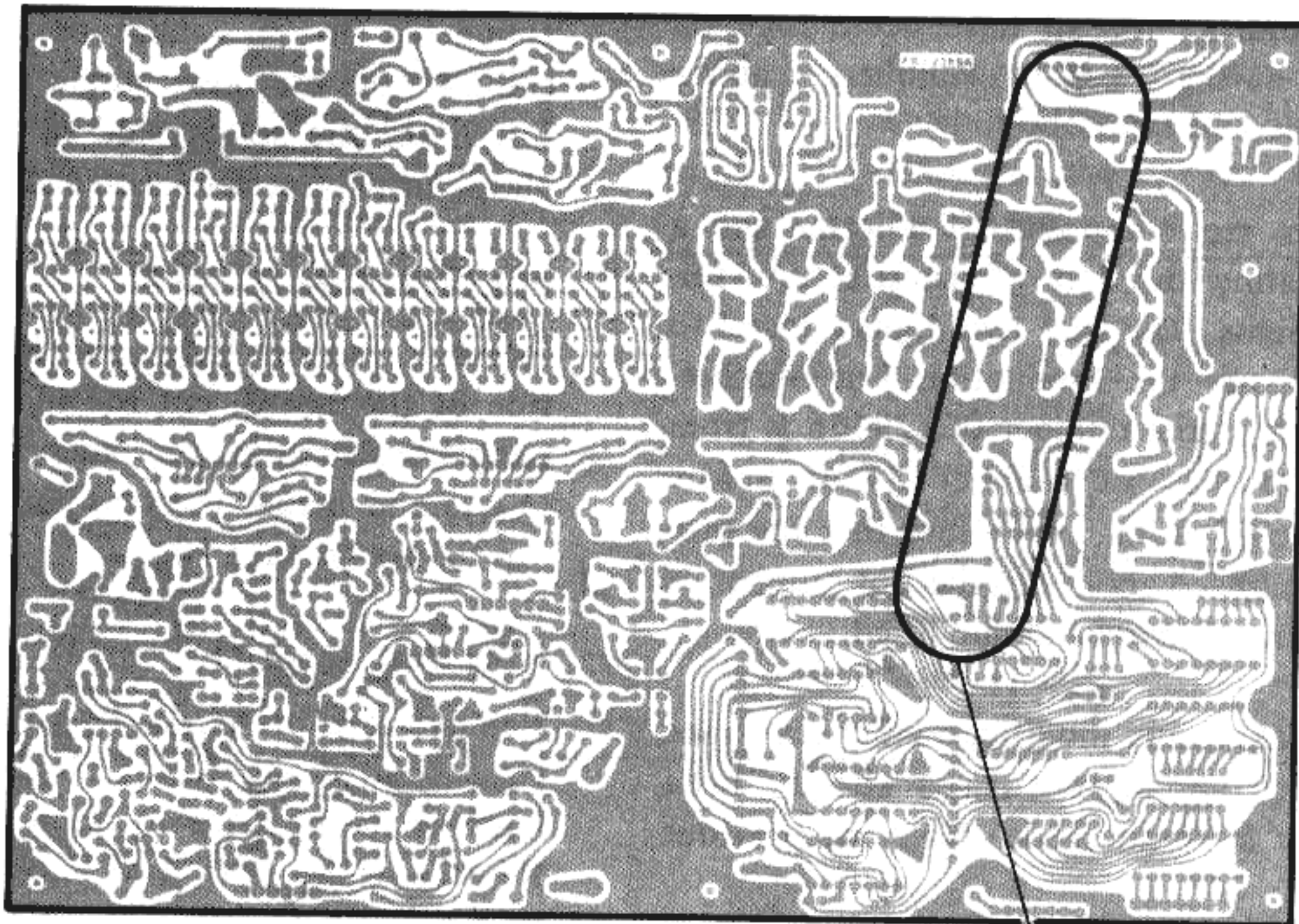

RF UNIT (PB-2389A)

Solder side

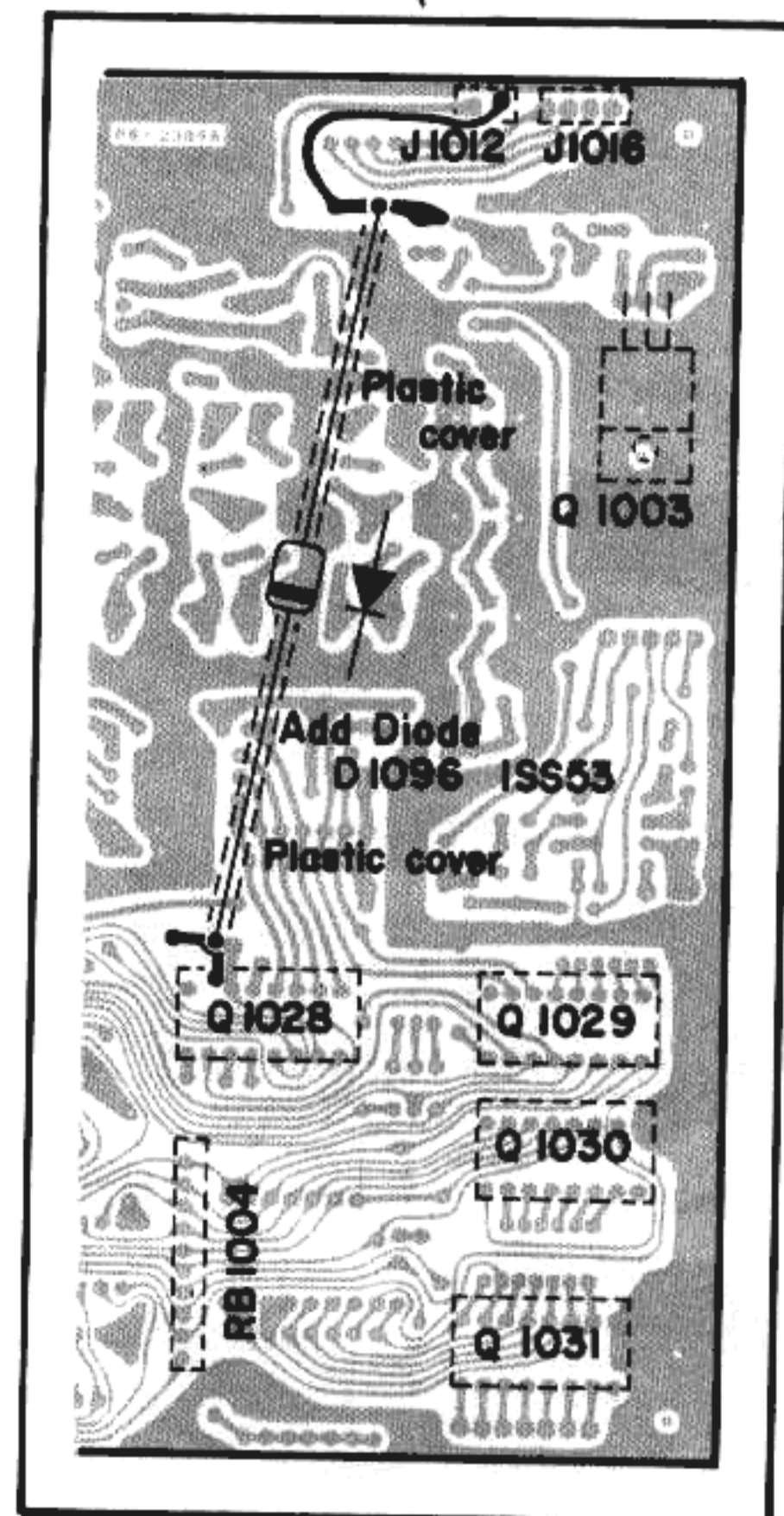
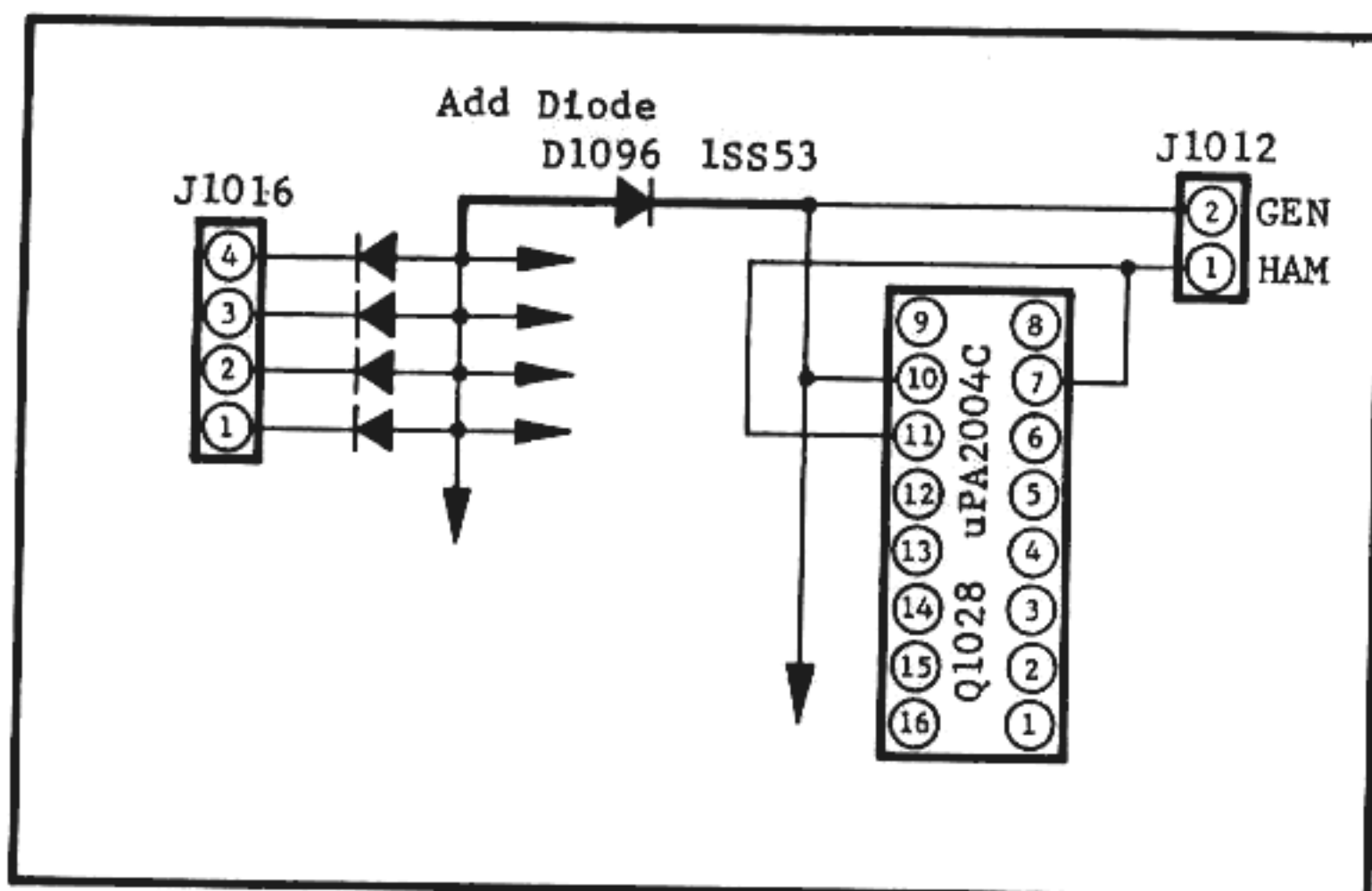

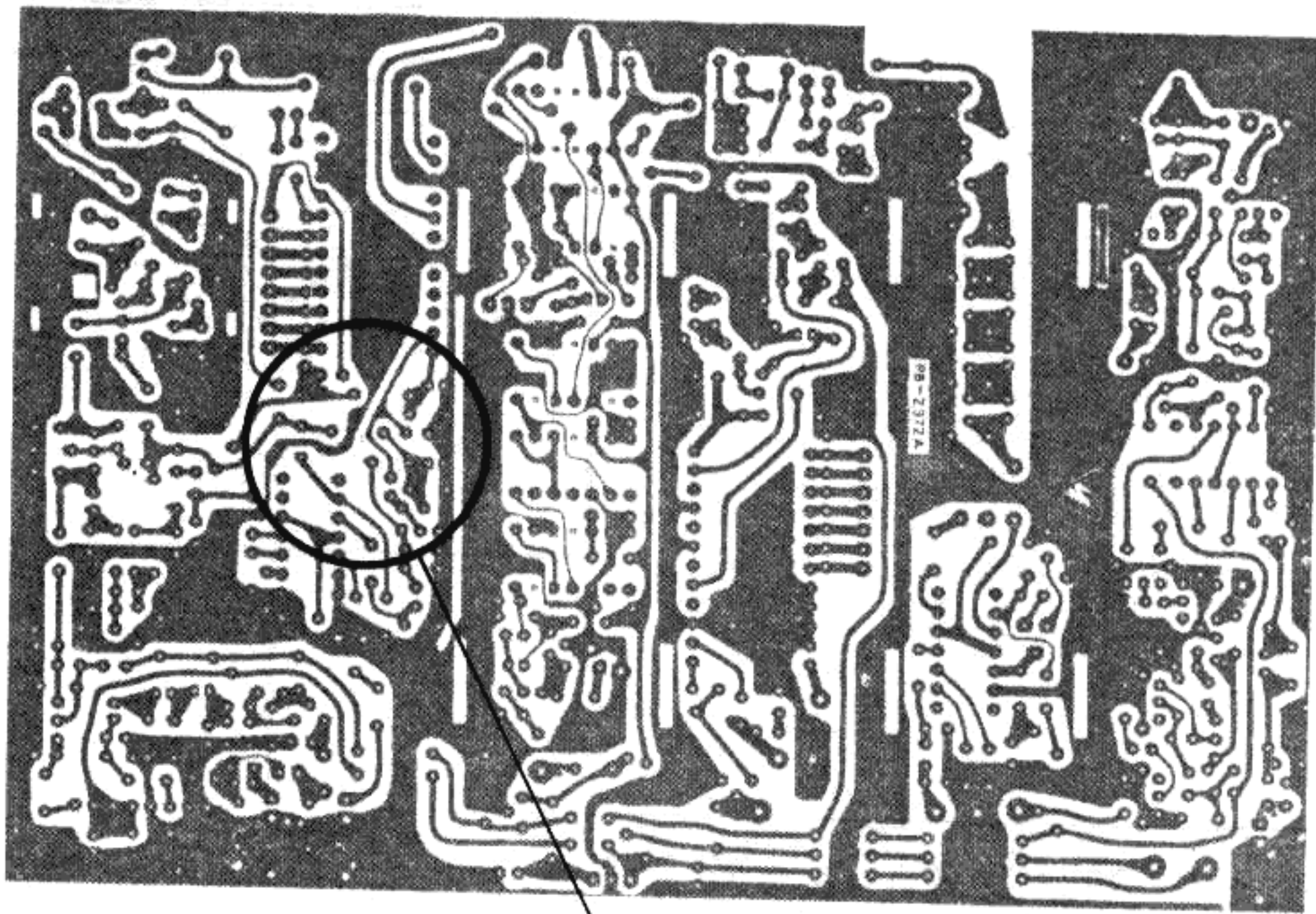

PLL/VCO UNIT

Solder side

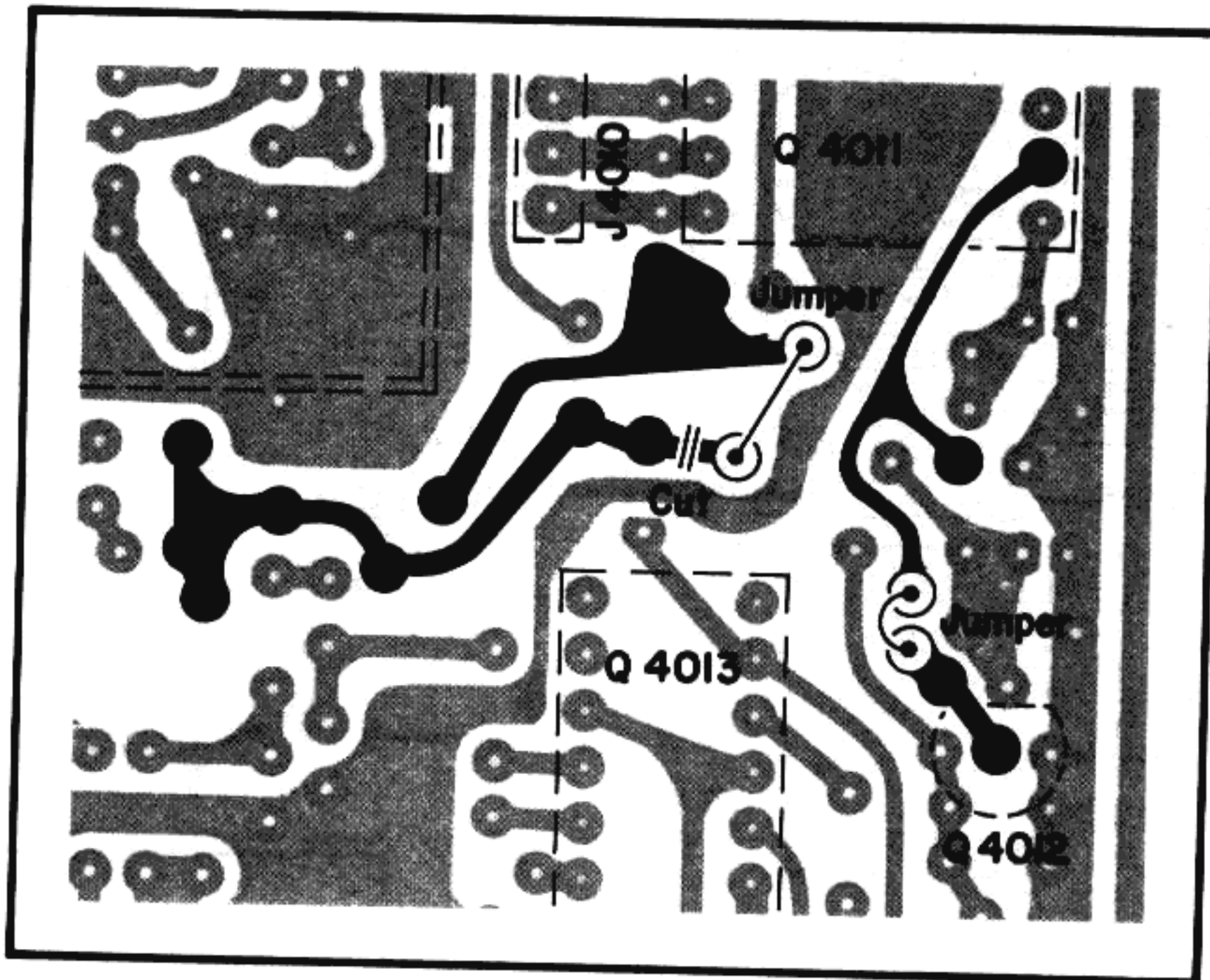

VFO UNIT

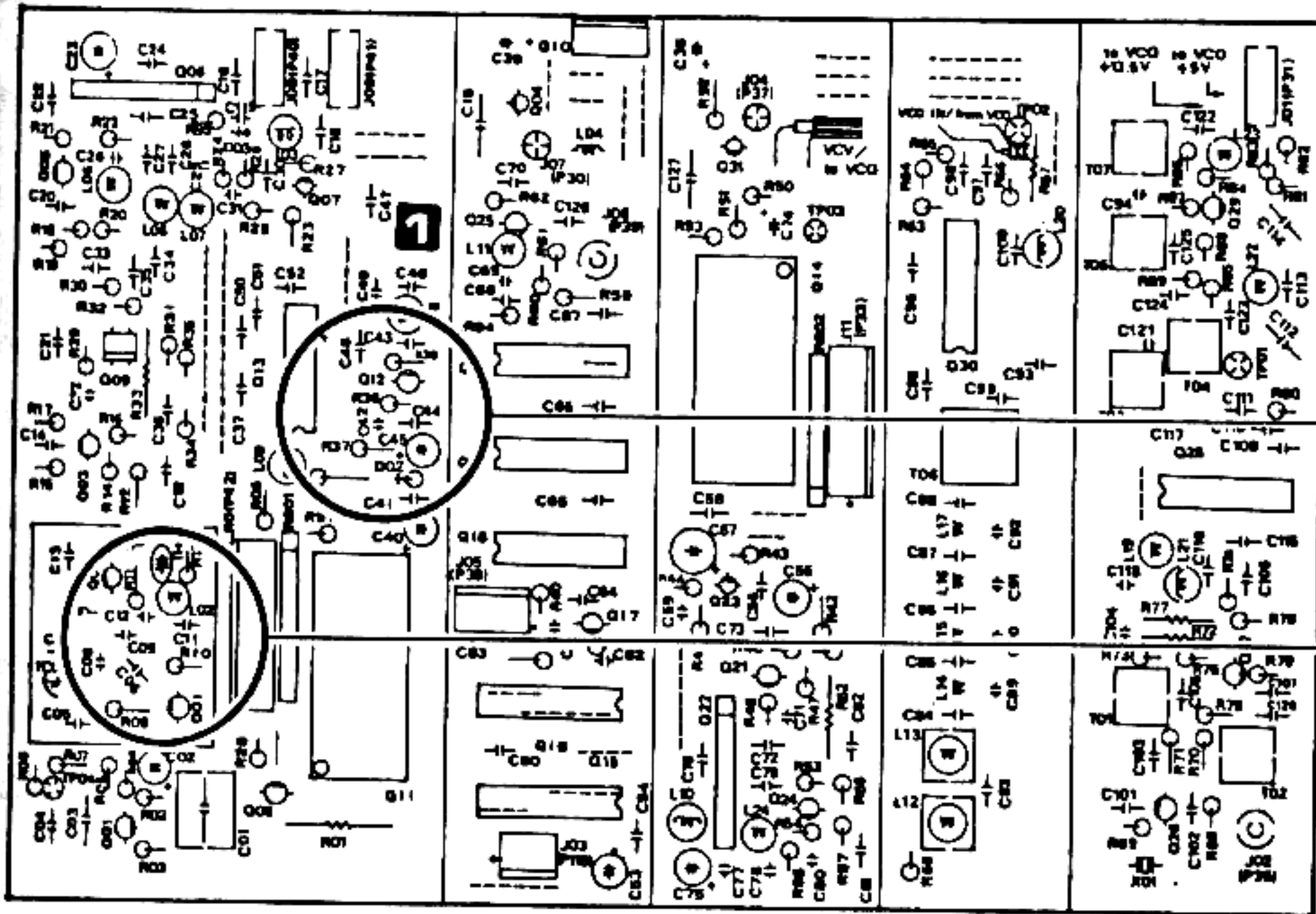

VFO UNIT (PB-2374A)

Component side

See below

See next page

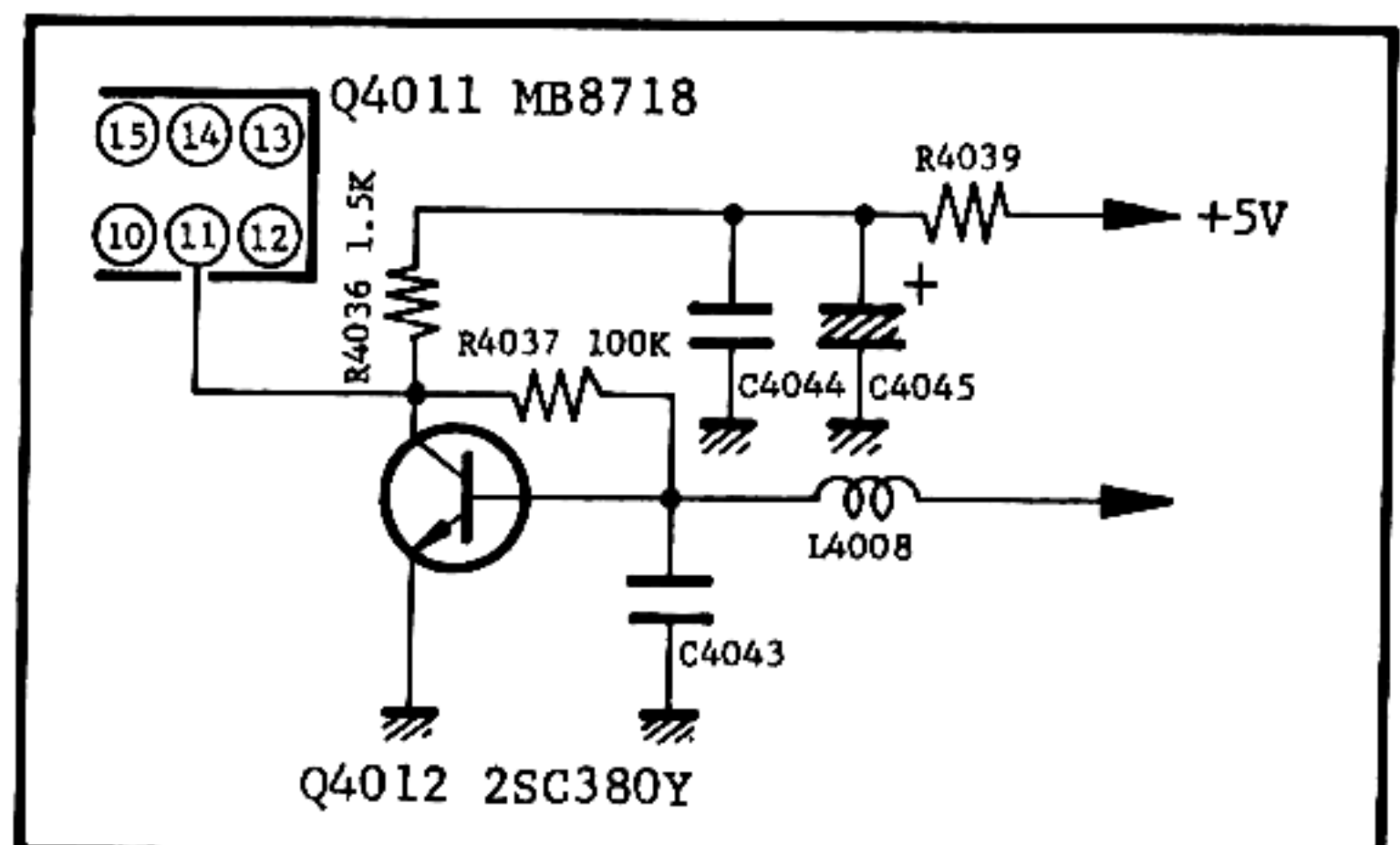
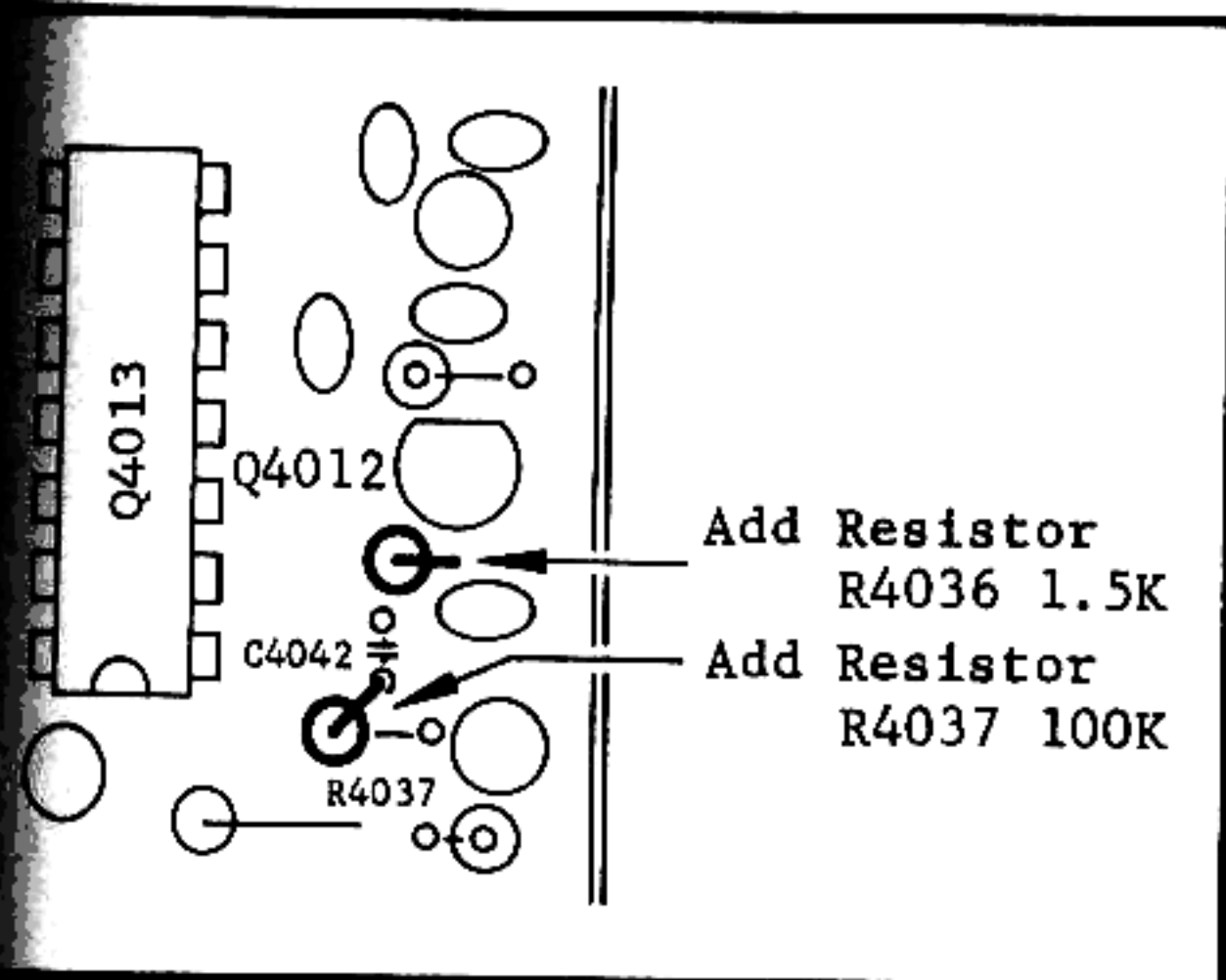
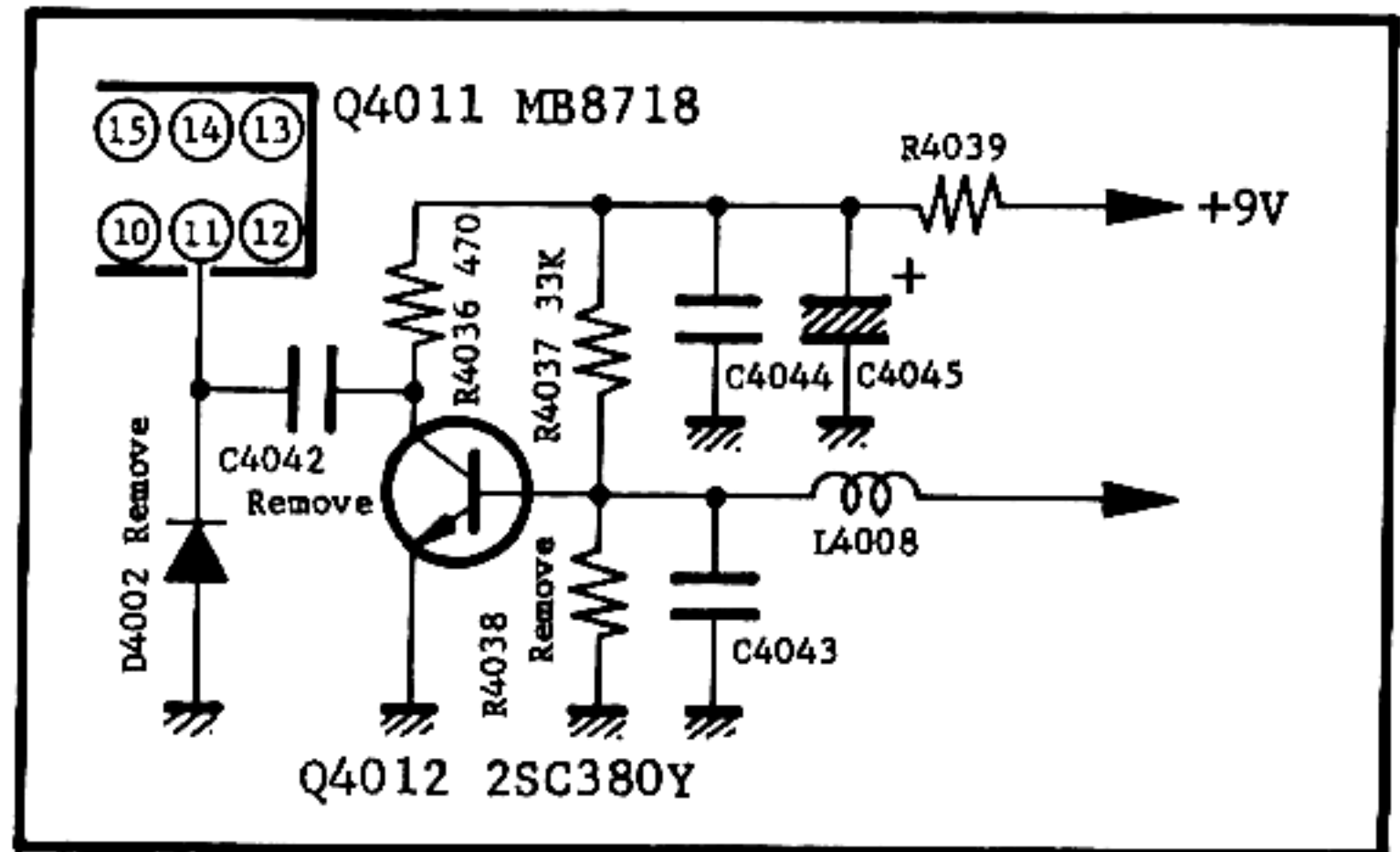
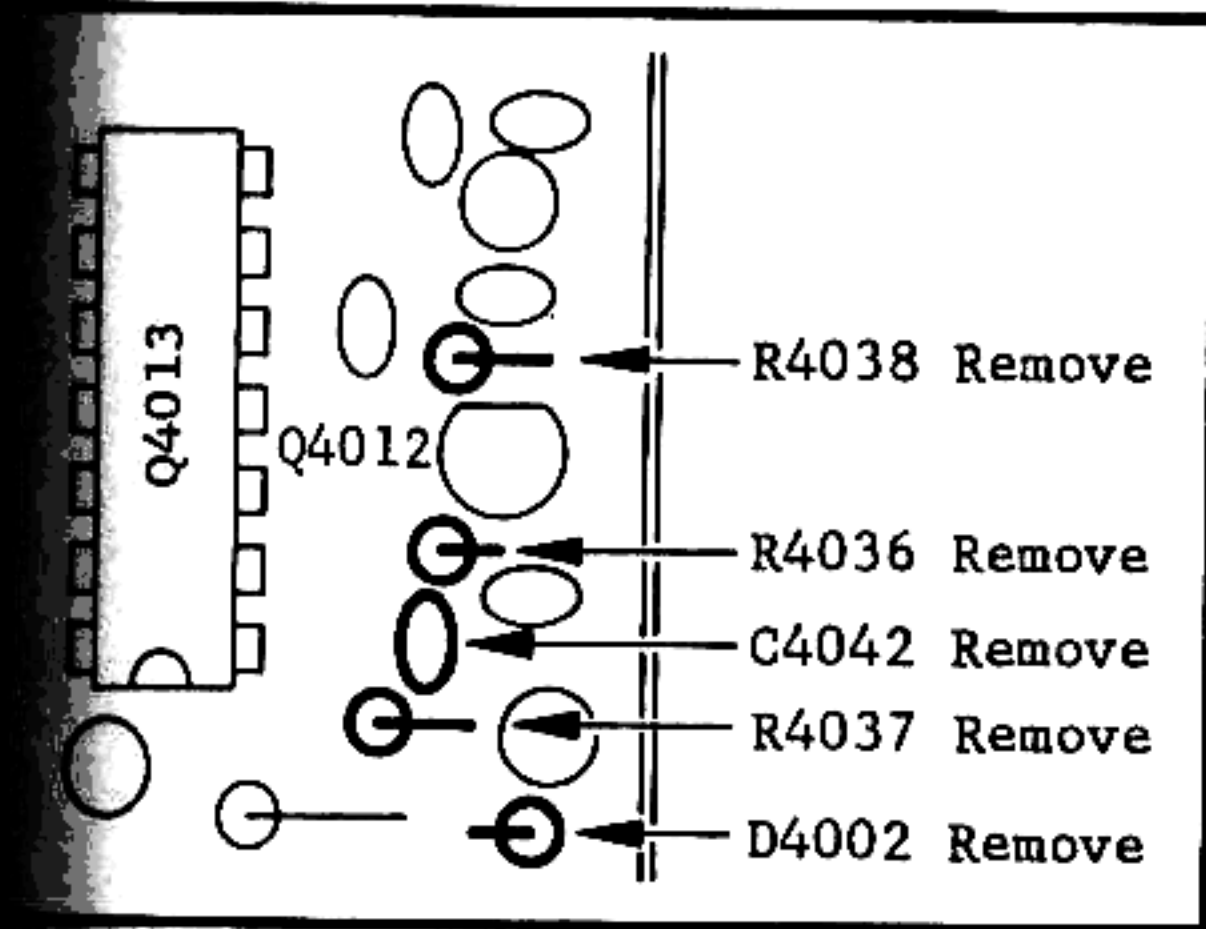

VCO (on VFO Unit)

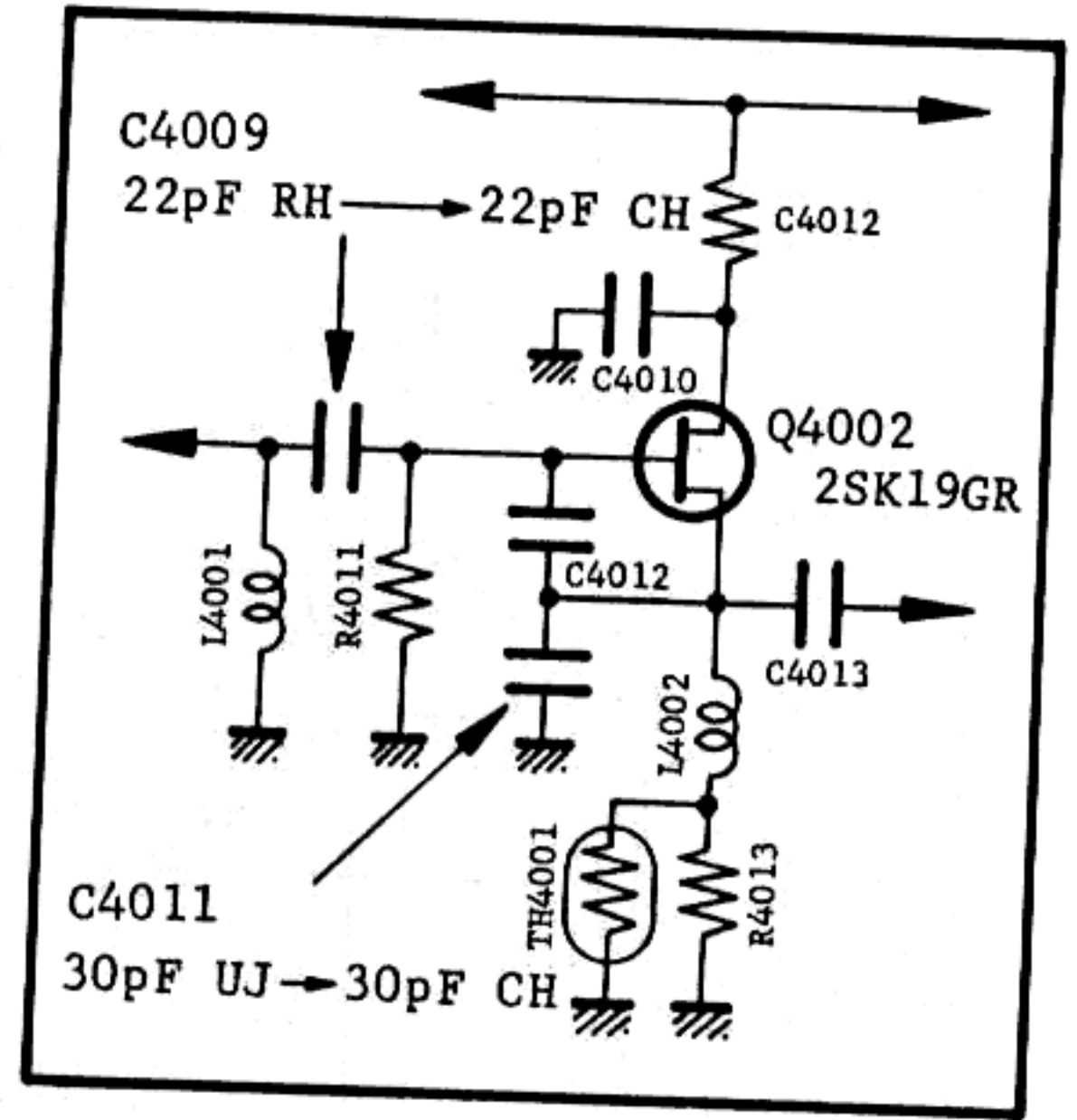
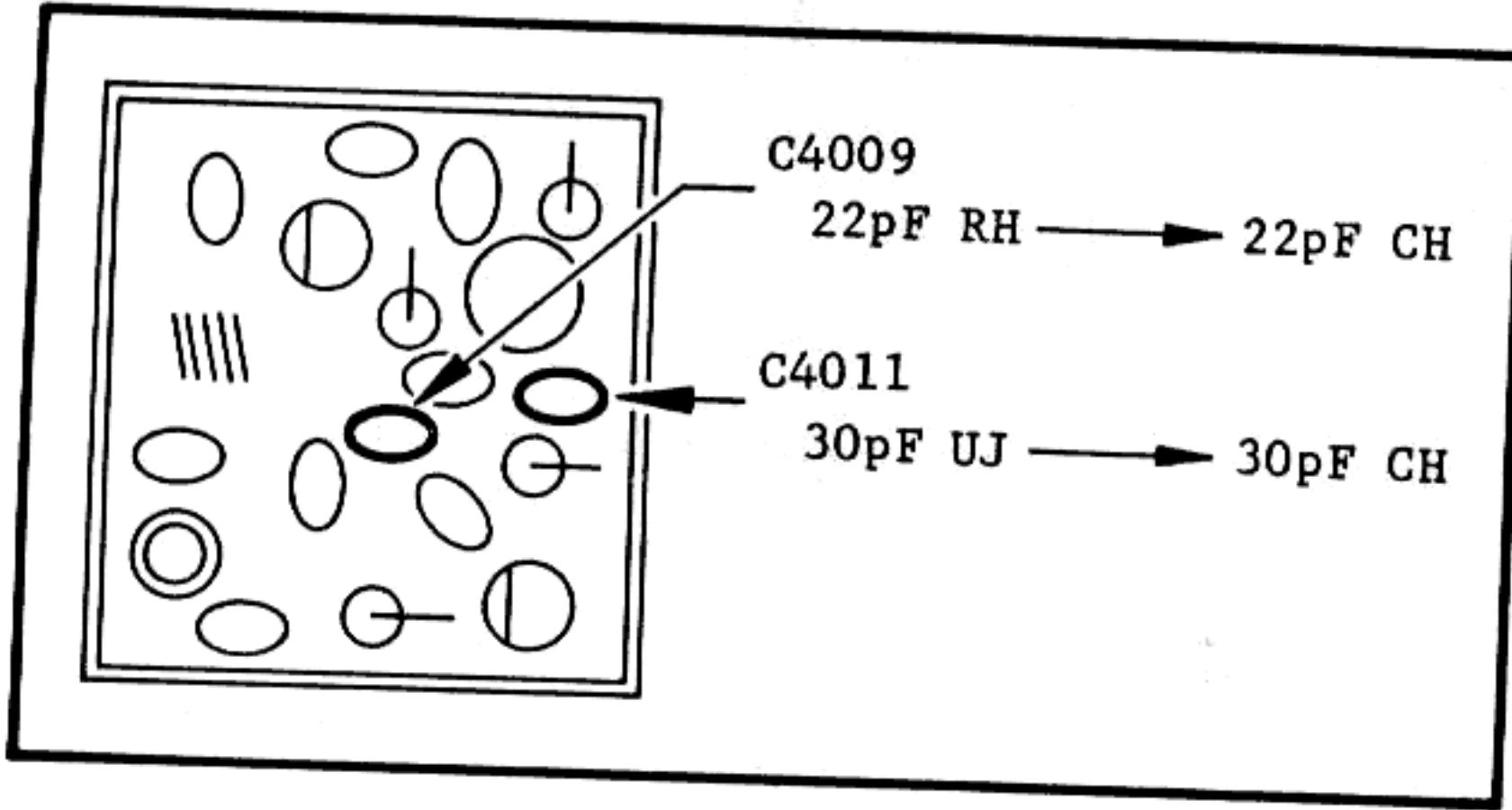

FSK UNIT

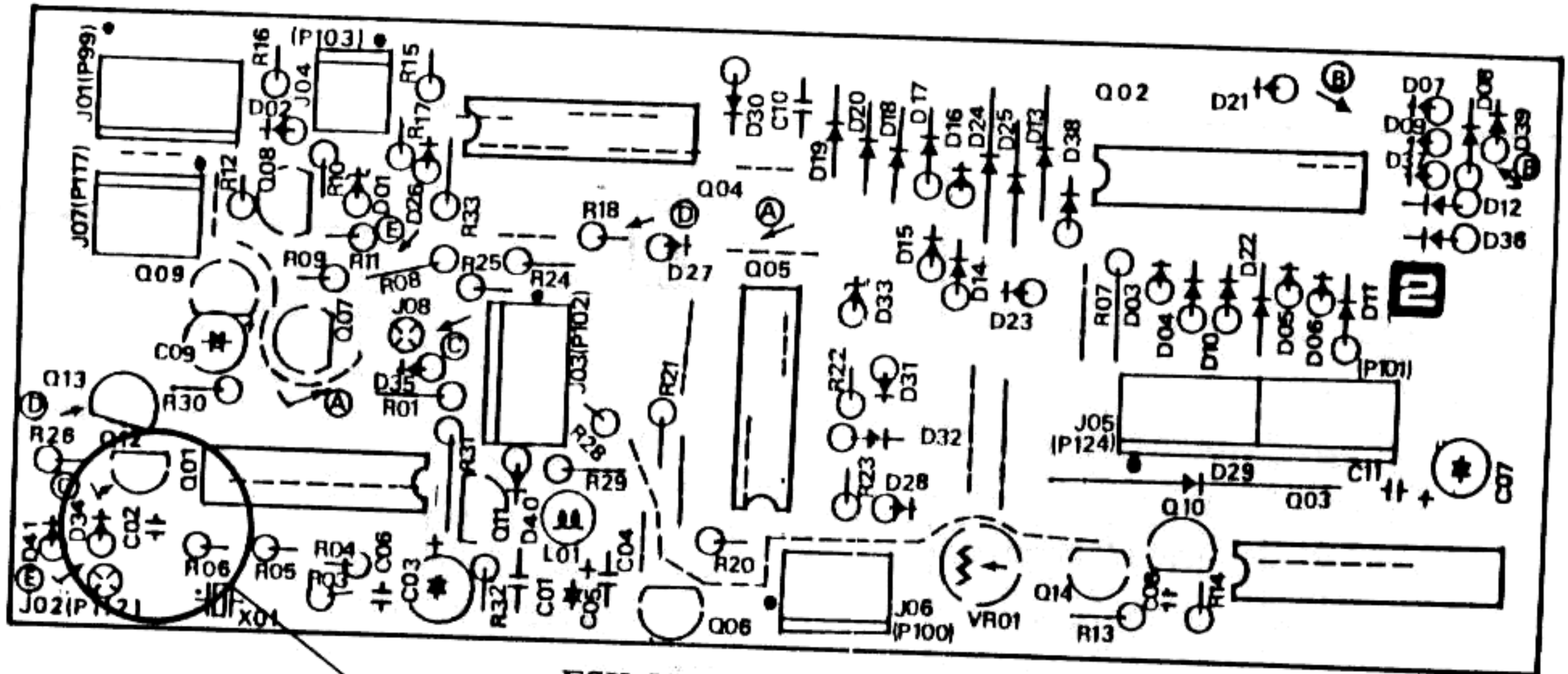

FSK UNIT (PB-2388B)

Component side

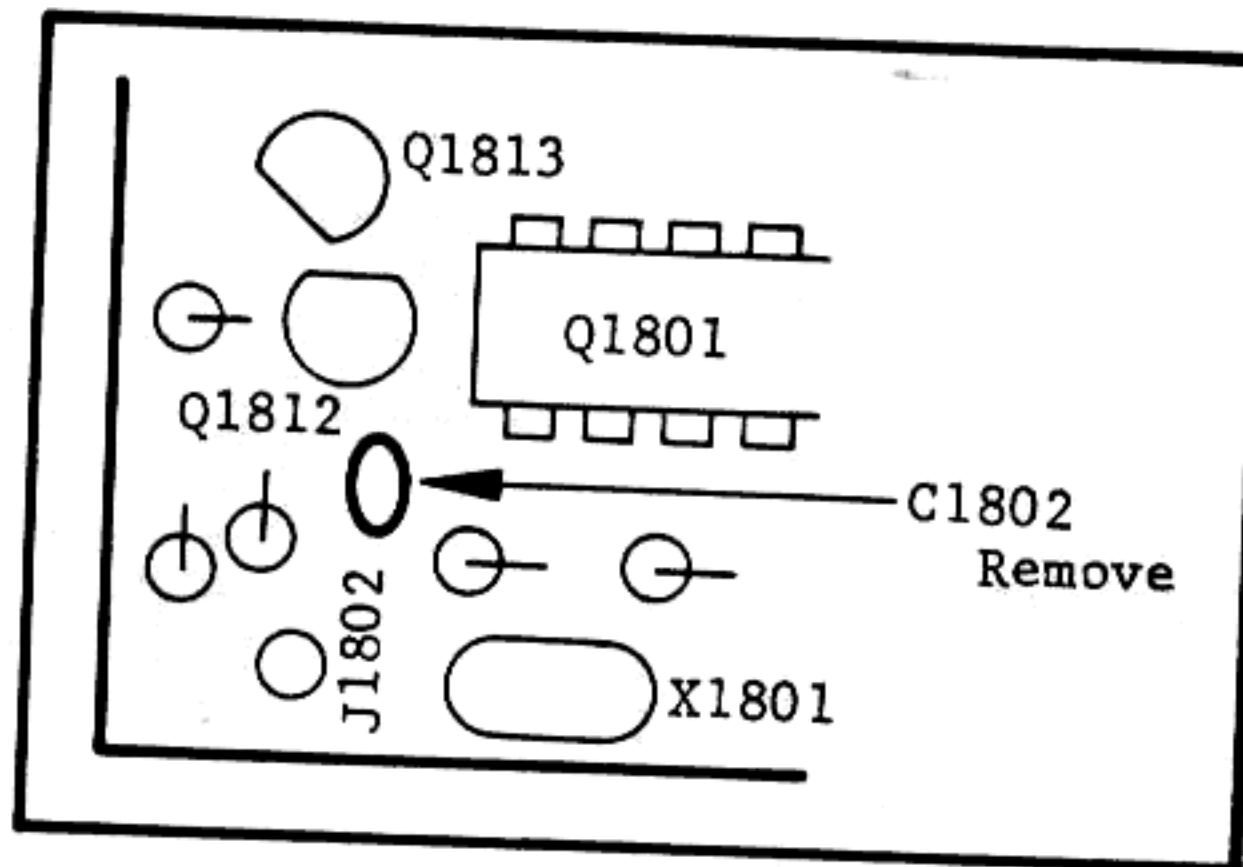

CAT SYSTEM SERIAL I/O DATA MANUAL FOR THE FT-980

The CAT (Computer-Aided Transceiver) System in the FT-980 allows use of an external micro-computer to control most of the operating functions of the transceiver. Control signal interface is via two serial data lines, accessible through the EXT CNTL jack on the rear of the transceiver. Yaesu offers a number of different Interface Units

for making the necessary data format conversions to connect some of the common brands of micro-computers. Software is provided with the Yaesu Interface Units. The EXT CNTL jack also provides access to the receiver AGC line, for application in user's programs.

EXT CNTL PINOUT

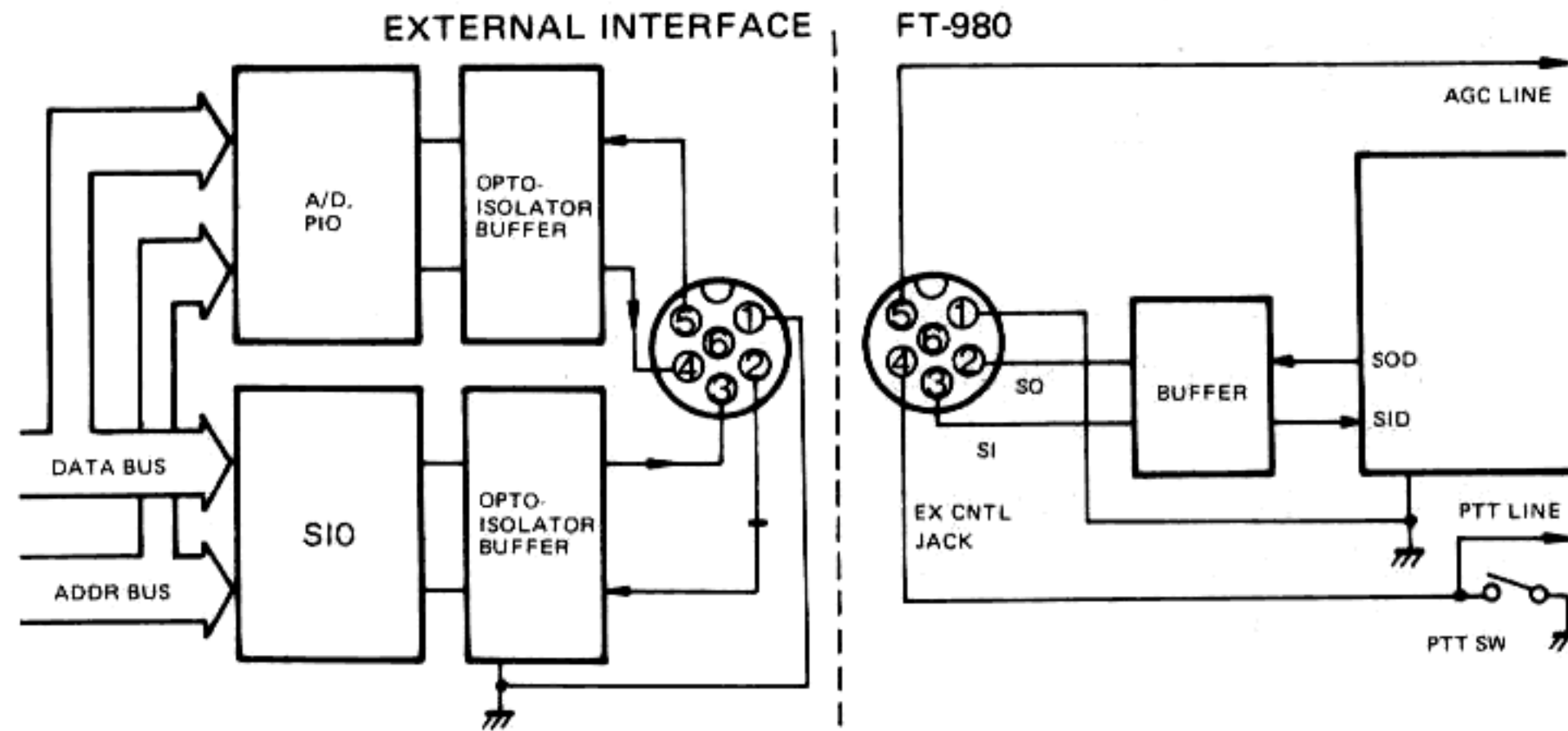

PIN NAME	DESCRIPTION
1 GND	Common ground for signal lines and shielding.
2 SO	Serial Output: standard TTL-level data line.
3 SI	Serial Input: accepts standard TTL-level data.
4 PTT	Push-to-talk line: ground to transmit. Open circuit voltage is 13.5V DC.
5 AGC	Automatic Gain Control: analog signal output ranging from +0.4V DC during strong signal reception, to +2.6V DC when no signal is being received.
6 NC	no connection

DATA TIMING FORMAT (4800 bits/second)

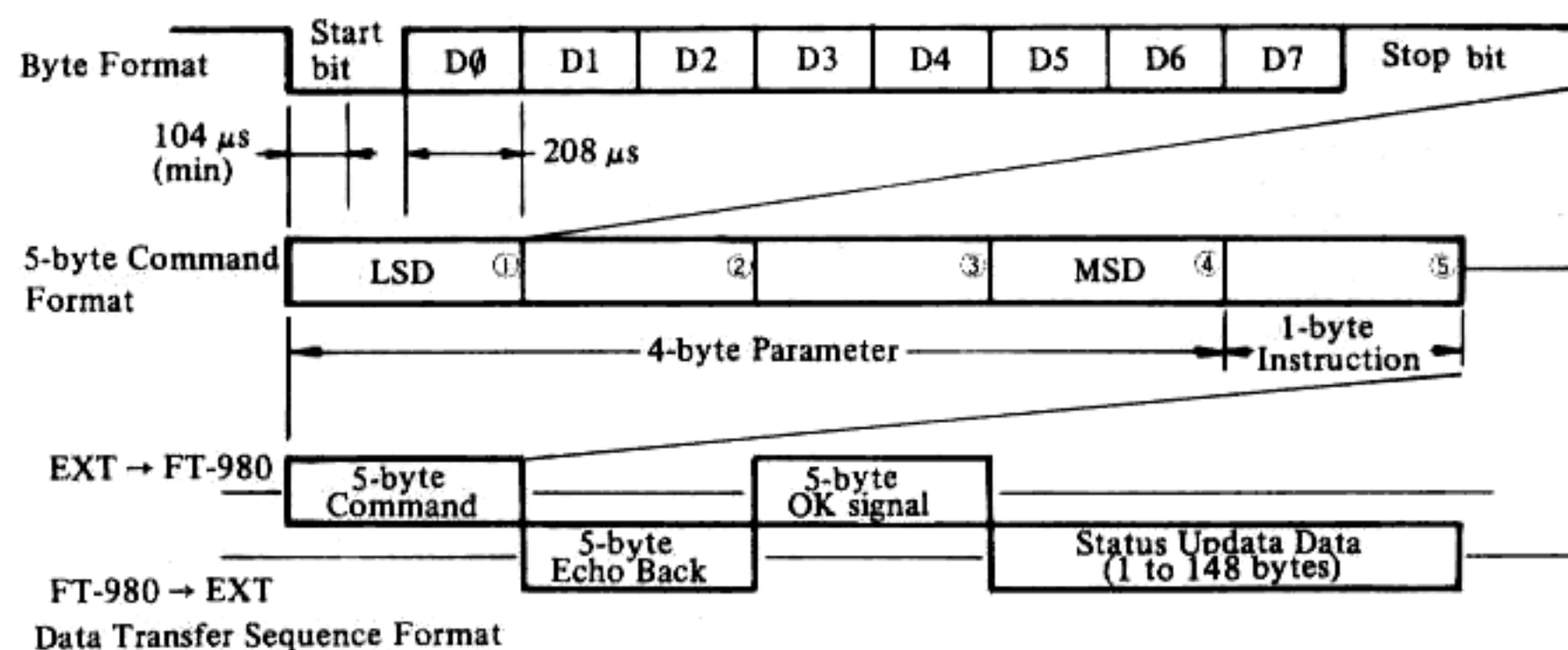

Shown below are examples of two basic types of commands. Each is five bytes in length.

Frequency Command
(Example: to set 14.25000 MHz)

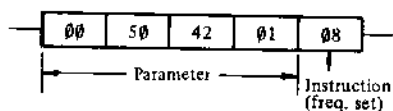

Mode Command
(Example: to select LSB mode)

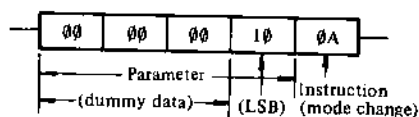

As illustrated in the Frequency Command example, frequency parameter data is sent least-significant digit first. The Mode Command example shows how dummy data ("00") is required in some commands, preceding significant parameter bytes. See Table 2 (page 16) for a list of Command Byte Codes.

Once the 5-byte command has been sent to the transceiver, it will respond with an "Echo Back" of the same command, if received correctly. The computer should be programmed to compare this Echo Back with the command sent, and if these do not match, the command must be sent to the transceiver again, as an error has occurred. If the Echo Back is identical to the original command, the computer must send a 5-byte "OK" signal (four "00" bytes followed by "0B"). The FT-980 will then execute the instruction, and return 1, 5, 6, 22 or 148 "Status Update" bytes to the computer to update the transceiver status in memory and on the display (Tables 1 and 3). No dummy bytes are included in the Status Update data returned from the FT-980.

"OK" Signal Command

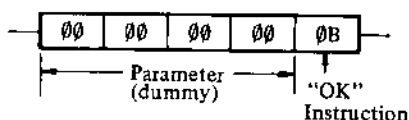

PROGRAMMING

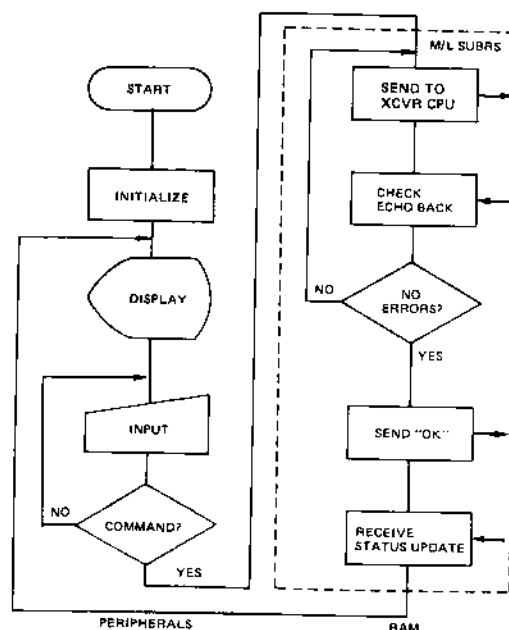

Data handling routines in the external computer should be in machine language, as BASIC and other high-level languages are generally too slow to handle the required routines during data transfer.

It is preferable to keep the command control of the FT-980 functions with the transceiver, and only switch to the external computer when necessary. The control source is switched by sending five "00" bytes, which constitutes the External Control ON/OFF Command. When this is sent to activate control from the computer, all status data (148 bytes) will be returned. Once the computer has sent its command(s) and received the Update Status from the FT-980, control should be returned to the transceiver by again sending the External Control ON/OFF Command. While the external computer is in control, the related front panel controls on the FT-980 are disabled.

All commands must contain five bytes, so when no parameter (or a shortened parameter) is required, dummy ("00") bytes must be inserted. Commands are exchanged in both directions, while Status Update data is unidirectional (from the FT-980 to the computer only), sent after the command has been executed by the transceiver. The length of the Status Update data depends upon the command executed, and can be 1, 5, 6, 22 or 148 bytes long, as indicated in Table 1.

TABLE 1. STATUS UPDATE DATA, BYTE FORMAT

Command Executed	Status Update Data Length	Status Update Bytes (see TABLE 3)
EXT CNTL ON/OFF	148	All (1-148)
STATUS CHECK	148	" "
+10 Hz	5	1-5
-10 Hz	5	"
IF WIDTH	1	23
IF SHIFT	1	26
FSK	1	24
RPTR SPLIT	6	1-5 and 25
FREQ SET	5	1-5
LDB	1	28
+100 Hz	5	1-5
-100 Hz	5	"
+5 kHz	5	"
-5 kHz	5	"
BAND UP	148	All (1-148)
BAND DOWN	148	" "
OTHERS (User Prog.)	22	1-22

Status Update Data does not include dummy bytes; all bytes are significant.

TABLE 2. COMMAND BYTE CODES

Command	Instruction byte	Parameter*	Parameter info	Command	Instruction byte	Parameter*	Parameter info
EXT CNTL ON/OFF	00			VFO STATUS SELECT	0A	1C	RXM
ALL STATUS CHECK**	01					1D	RXV
+10Hz	02					1E	MR
-10Hz	03					1F	VFO
IF WIDTH	04	00 FE	7F=±0.00	GENR VFO	0A 21		
IF SHIFT	05	00 1E	0F=±0.0	HAM VFO	0A 22		
FSK	06	00	AS PER FSK SHIFT SWITCH	TAB U-SET	0A 23		
		40	425Hz	TAB L-SET	0A 24		
		80	850Hz	TAB ON/OFF	0A 25		
		C0	170Hz	TX CLAR	0A 26		
REPEATER SPLIT	06	00	SEE STATUS UPDATE BYTE 25 IN TABLE 3.	RX CLAR	0A 27		
		80		MEMORY SHIFT	0A 28		
		40		MEMORY WRITE	0A 29		
		C0		100Hz UP	0A 18		
		20		100Hz DWN	0A 20		
		A0		5kHz UP	0A 2C		
FREQ. SET	08	xx xx xx xx	FREQ.	5kHz DWN	0A 2B		
				BAND UP	0A 2F		
LDB	09			BAND DWN	0A 2D		
MEMORY CHANNEL	0A	00 0F		"OK" SIGNAL	0B		***
MODE SELECT	0A	10	LSB				
		11	USB				
		12	CWW				
		13	CWN				
		14	AMW				
		15	AMN				
16	FSK						
17	FM						
OFFSET	0A	1B					

* Parameter codes must include dummy bytes (00) where required to make all parameter codes 4 bytes long. Commands requiring one parameter byte have first three bytes as dummy.

** ALL STATUS CHECK returns entire contents of status memory in FT-980.

*** The "OK" Signal is required for execution of all commands, and it is not echoed back.

TABLE 3. STATUS UPDATE BYTE CODES (from FT-980)

BYTE NO.	BYTE CODES						
1	STATUS FLAG BITS	0	TX=1 RX=0				
		1					
		2					
		3	SPLIT=1				
		4					
		5	VFO=1 MR=0				
		6	UP=1, DWN=0				
	CLAR	7	ON=0, OFF=1				
2-5	OPERATING FREQUENCY						
6	MODE 00=LSB 01=USB 02=CWW 03=CWN 04=AM-W 05=AM-N 06=FSK 07=FM						
7	VFO STATUS 00=GEN 80=HAM 81=AUX1 HAM/GEN/AUX 82=AUX2 83=AUX3						
8-11	UPPER TAB (FREQ)						
12-15	LOWER TAB (FREQ)						
16	MEM CH SELECTOR POSITION (00-0F)						
17	MODE SELECTOR POSITION (00-07)						
18	XCVR OFFSET (01=SPLIT, 00=SIMP)						
19	SELECT SW 00=VFO, 02=RX M 01=MR, 03=RX V						
20	TAB FLAG 00=OFF, 80=ON						
21	CLARIFIER FLAG	RX		TX			
		00=OFF,		OFF			
		20=ON,		OFF			
		40=OFF,		ON			
60=ON,		ON					
22	MEM SHIFT 00=OFF 01=ON						
23	IF WIDTH 00=FE (CTR=7F)						
24	FSK SHIFT 00=INT 40=425 80=850 C0=170						
25	REPEATER SPLIT CODE						
		BAND	50	70	144	220	430
			54	74	148	226	440
	DATA						
	00		+1	±0	+0.6	+1.6	+5
	80		-1	±0	-0.6	-1.6	-5
	40		+1	±0	+0.6	+1.6	+7.6
	C0		-1	±0	-0.6	-1.6	-7.6
	20		+1	±0	+0.6	+1.6	+1.6
	A0		-1	±0	-0.6	-1.6	-1.6
E0		±0	±0	±0	±0	±0	

BYTE NO.	BYTE CODES			
26	IF SHIFT 00-1E (CTR=0F)			
27	EXT CNTRL 00=OFF, 01=ON			
28	LDB FLAG 00=OFF, 01=ON			
29	MODE OF SELECTED MEM CHANNEL (same code format as BYTE No. 6)			
30	VFO STATUS OF SELECTED MEM CH (same code format as BYTE No. 7)			
31-34	MEMORY SHIFT FREQUENCY			
35-38	MEMORY CLARIFIER FREQUENCY			
39	MODE OF SELECTED VFO (same code format as BYTE No. 6)			
40	VFO STATUS OF SELECTED VFO (same code format as BYTE No. 7)			
41-44	HAM VFO FREQUENCY			
45-48	GEN VFO FREQUENCY			
49-52	CLARIFIER FREQUENCY			
53-58	MEM CH1 FREQ., VFO STATUS and MODE			
59-64	" CH2 " " " " " " "			
65-70	" CH3 " " " " " "			
71-76	" CH4 " " " " " "			
77-82	" CH5 " " " " " "			
83-88	" CH6 " " " " " "			
89-84	" CH7 " " " " " "			
85-100	" CH8 " " " " " "			
101-106	" CH9 " " " " " "			
107-112	" CH10 " " " " " "			
113-118	" CH11 " " " " " "			
119-124	" CH12 " " " " " "			
125-130	" CH13 " " " " " "			
131-136	" CH14 " " " " " "			
137-142	" CH15 " " " " " "			
143-148	" CH16 " " " " " "			

* Example of CH data:
USB, HAM, 14.25000MHz is coded as
01 81 01 42 50 00

UNIT LOCATIONS

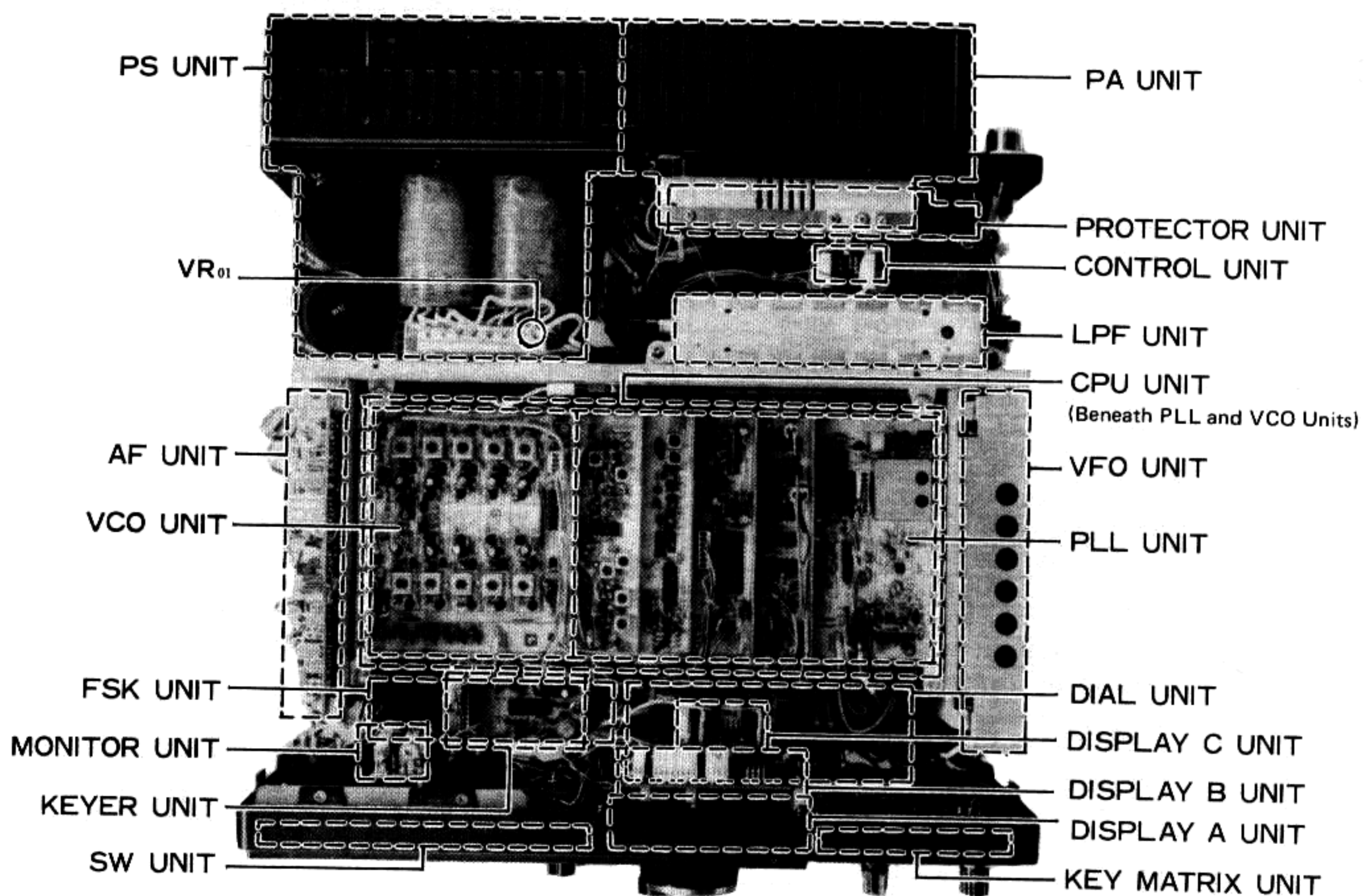

TOP VIEW

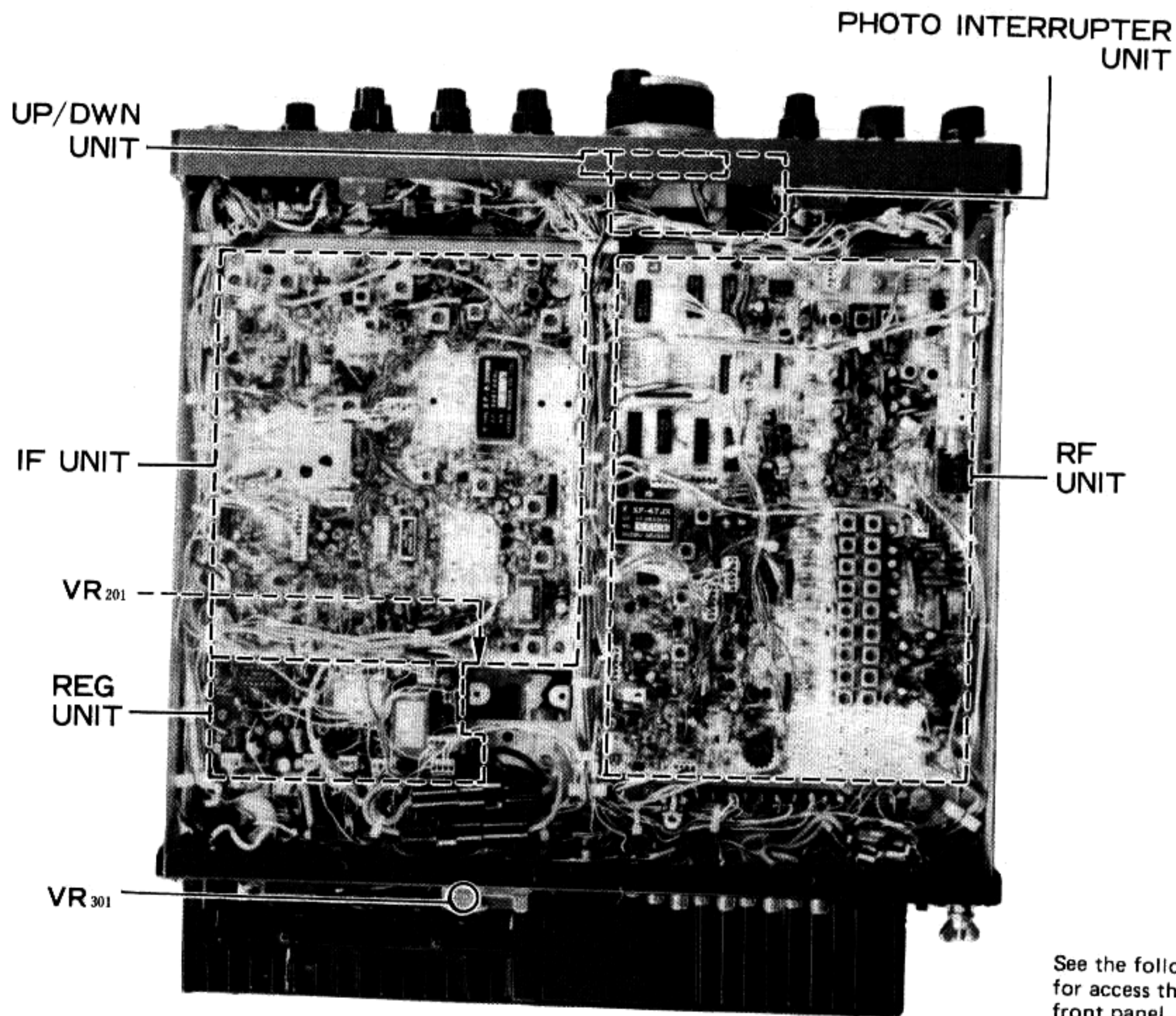

BOTTOM VIEW

See the following page for access through the front panel.

UNIT ACCESS THROUGH THE FRONT PANEL

The inside of the front panel and the units attached thereto can be easily accessed by performing the following steps:

1. Remove the top and bottom covers as shown on page 7.
2. With the transceiver placed on its side, loosen the two hex head setscrews at the front of the

ATT selector shaft coupler, and slide the shaft out of the front panel.

3. Remove the upper front panel mounting screws (one on either side of the transceiver), and loosen the lower screws. The front panel may now be folded forward, with the lower screws serving as hinges.

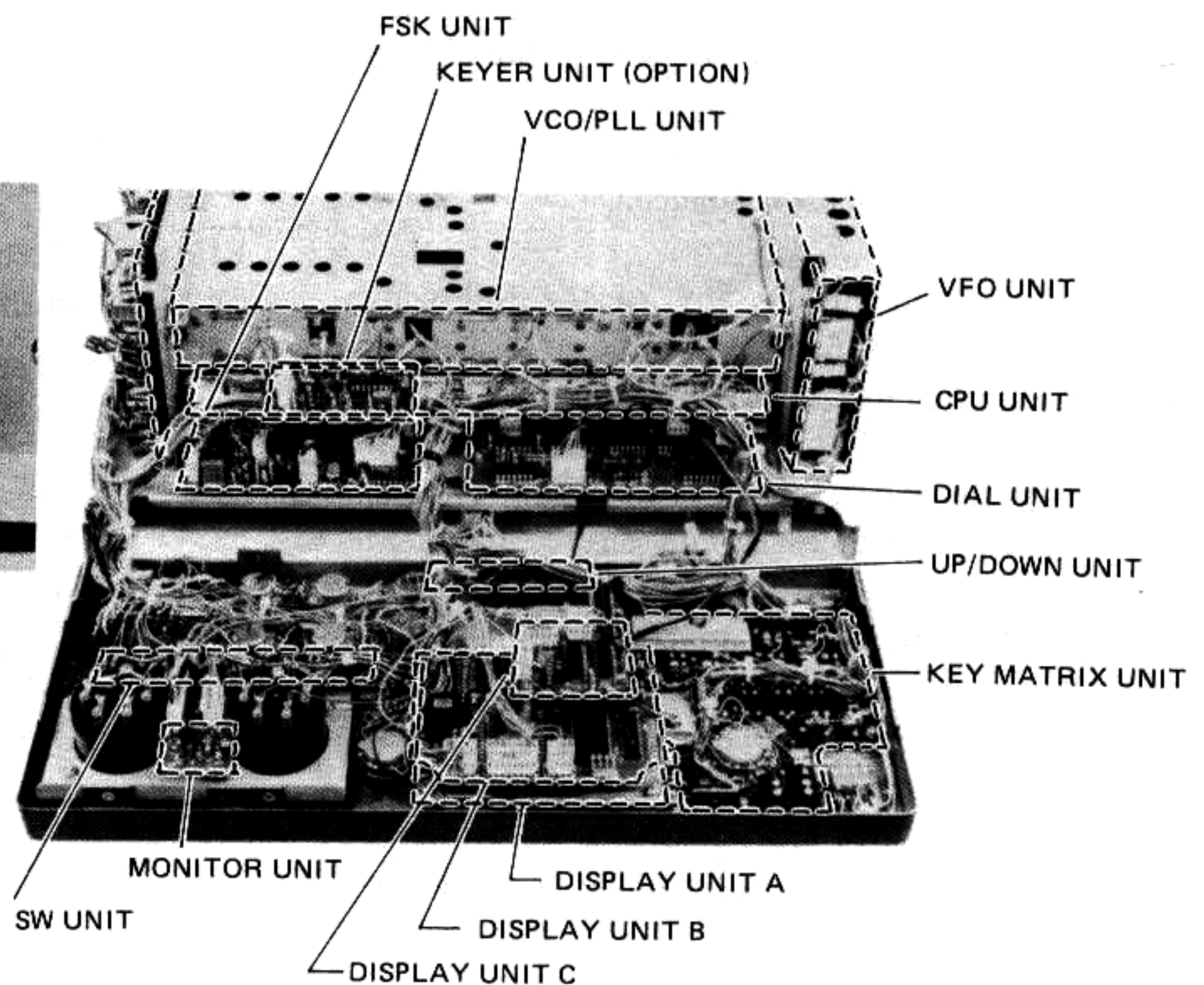
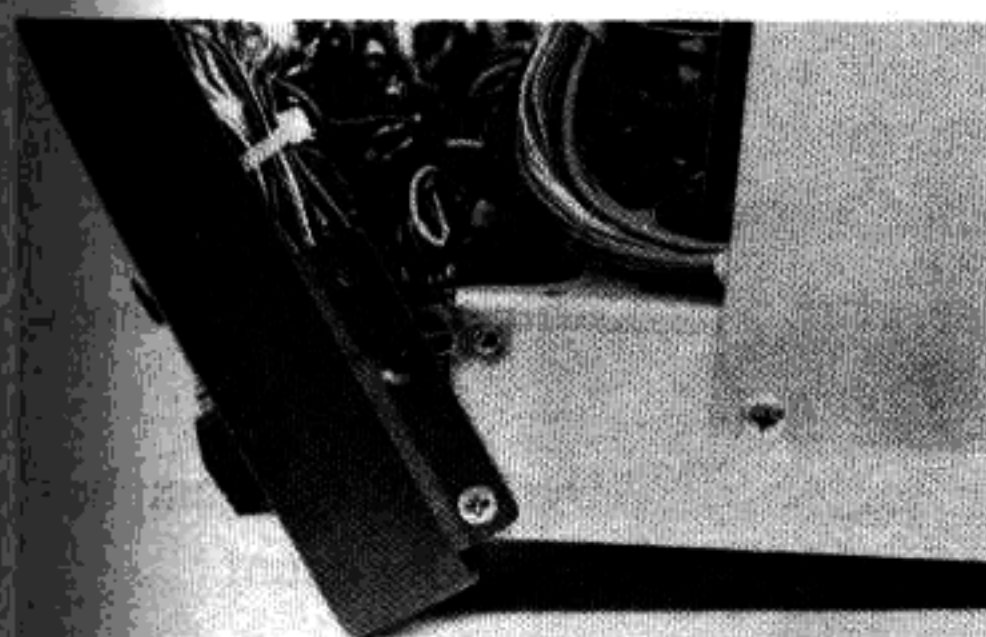
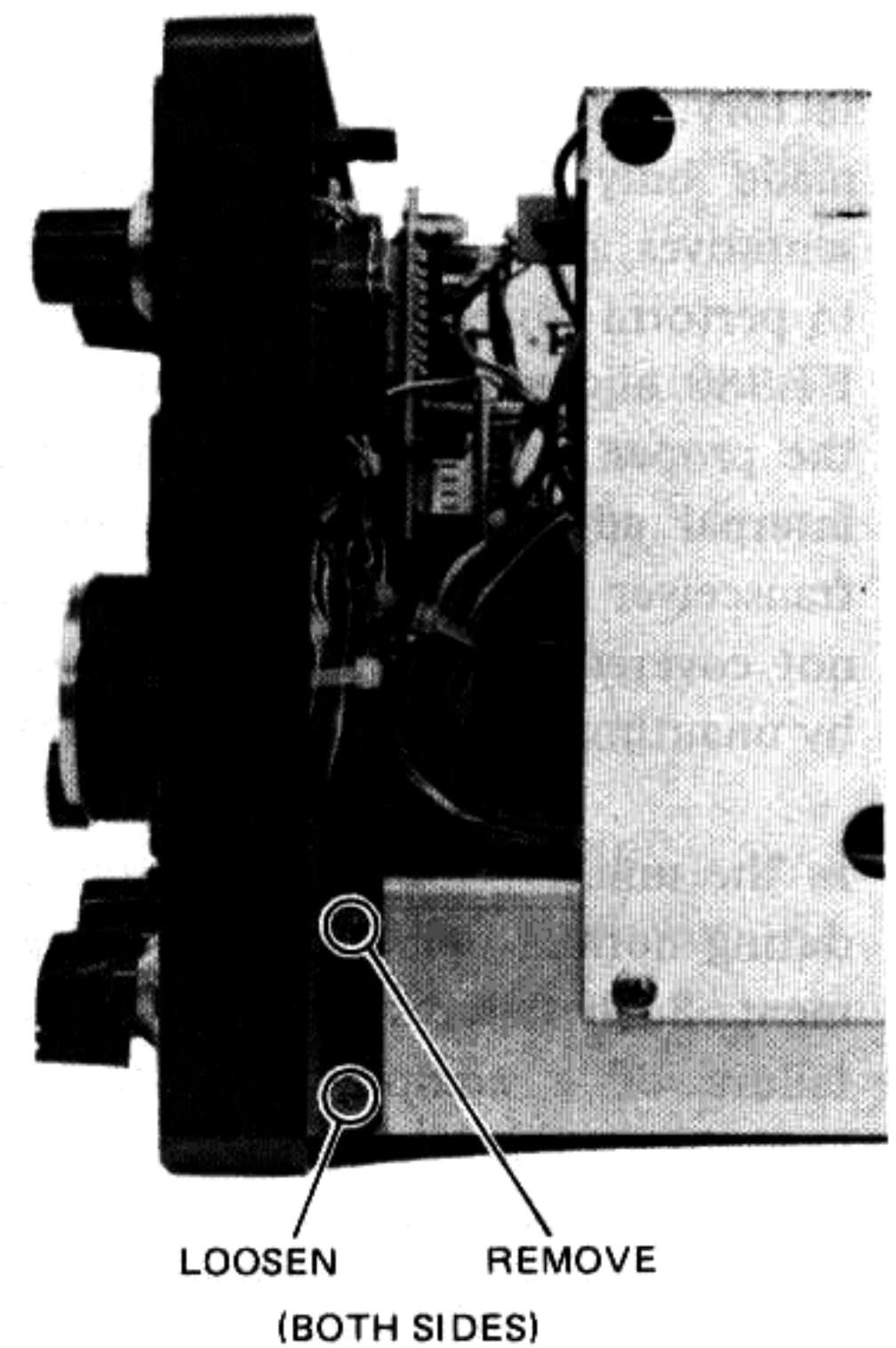
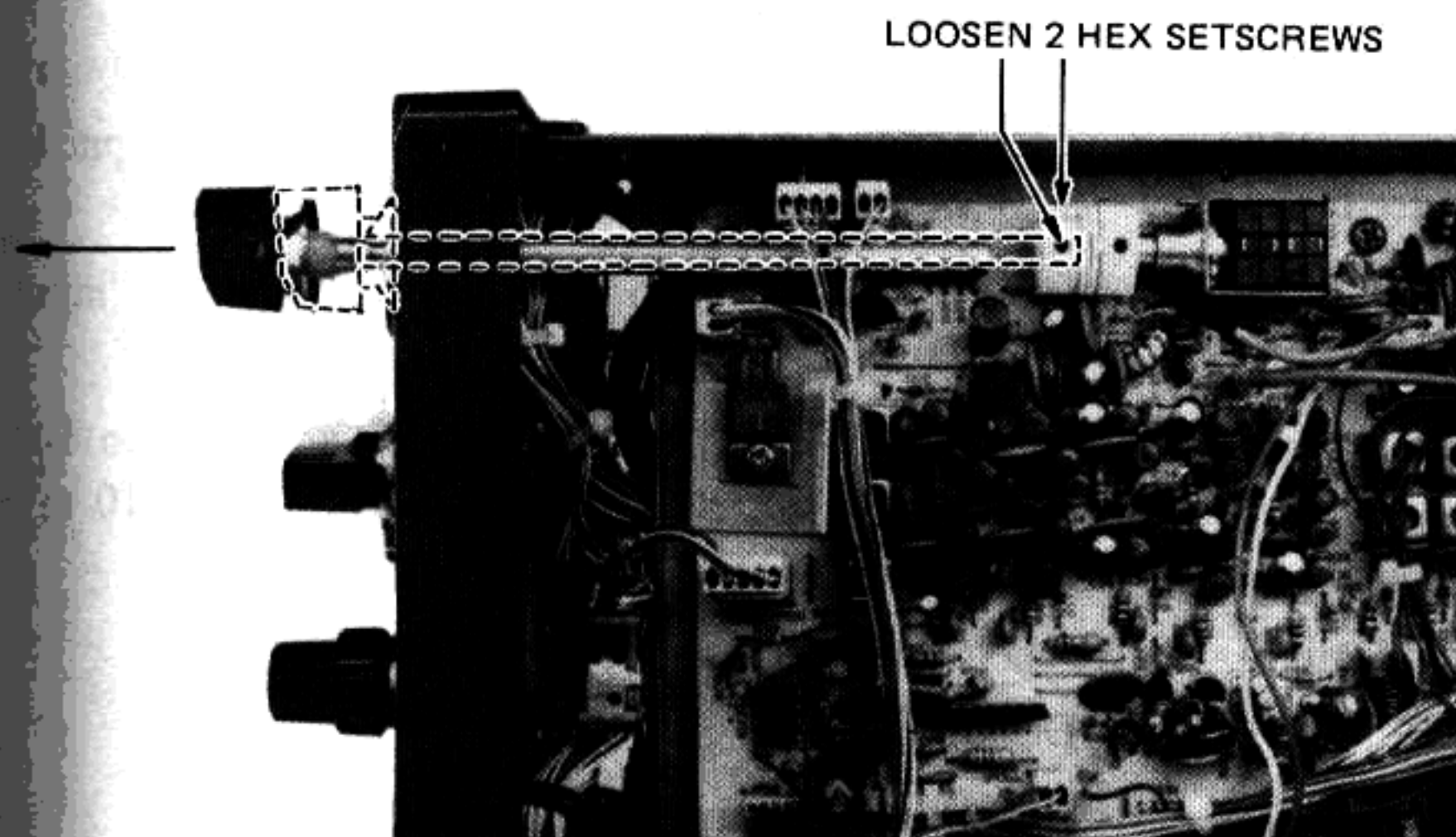

SERVICE AND ALIGNMENT

The FT-980 is carefully designed to allow the knowledgeable operator to make all adjustments required for various station conditions, modes and operator preferences simply from the controls on the front and rear panels, without opening the case of the transceiver. These adjustments are described in the FT-980 Operating Manual.

The following procedures cover the sometimes critical and tedious adjustments that are not normally required once the transceiver has left the factory. We recommend that these adjustments be made only by authorized Yaesu service representatives, as many are interdependent and difficult to perform correctly without prior experience with FT-980 alignment. Without such experience and the proper test equipment, any attempt to make internal adjustments is likely to cause degraded transceiver performance, the correction of which is not covered by the warranty policy when caused by unauthorized internal adjustments.

In the unlikely event that a sudden failure occurs during normal operation, do not attempt realignment. Such failures are almost always due to the failure of a component, often in an external accessory, or a problem with the antenna system. Once the external connections have all been checked, if the transceiver is still suspect, the Yaesu representative through whom the transceiver was originally purchased should be contacted immediately for instructions regarding repair. Authorized Yaesu service technicians automatically perform complete performance checks and realignment of all circuits that may be affected once a faulty component has been replaced.

Those who do undertake any of the following alignments are cautioned to proceed only at their own risk. Yaesu must reserve the right to change circuits and alignment procedures in the interest of improved performance, without notifying owners. Under no circumstances should any realignment be attempted unless the normal function and operation of the transceiver are clearly understood, the malfunction has been carefully analyzed and any faulty components replaced, and the need for a specific realignment determined to be absolutely necessary. Procedures not involving adjustments are termed checks, and are included for troubleshooting purposes.

The following test equipment (and thorough familiarity with its use) is required for complete alignment. While most steps do not require all of the equipment listed, the interactions of such adjustments may require that more complex adjustments be performed afterwards. Do not attempt to perform only a single step unless it is clearly isolated electrically from all other steps. Rather, have all test equipment ready before beginning, and follow all of the steps in the order that they are given in each section.

Alignment Equipment

- Frequency counter with accuracy of 0.1 ppm to 100 MHz
- DC voltmeter with at least 10-Megohm input impedance
- RF voltmeter with at least 5% accuracy to 100 MHz, high impedance, and ranging from 10 mV to 3 Vrms
- AF voltmeter
- DC ammeter ranging to 20A
- DC milliammeter ranging to 500 mA
- Spectrum analyzer or monitor receiver capable of receiving 61–63 MHz; for 62 MHz Bandpass alignment
- Sweep generator covering 5–30 MHz
- X-Y oscilloscope with 35 MHz bandwidth
- RF in-line wattmeter
- Resistive dummy load, 50 ohms, 150W; three required for Reverse ALC alignment
- RF signal generator covering 1–30 MHz, with calibrated output levels from 5 dB μ to 100 dB μ
- AF signal generator with calibrated output levels from 1 mV to 25 mV
- FM deviation meter/SINADer and RF sampling coupler ("T") for FM modulator alignment
- Monitor scope for transmitter output display
- Linear detector for 1–30 MHz

VFO UNIT

A. 30 MHz Coil

Connect the RF voltmeter to TP₇₀₀₈ and adjust T₇₀₁₁ for maximum RF voltage (nom. 140 mVrms).

B. 60 MHz Coil

Connect the RF voltmeter to pin 5 of Q₇₀₁₄ and adjust T₇₀₁₃ for maximum RF voltage (nom. 120 mVrms).

C. 90 MHz Coil

Connect the RF voltmeter to TP₇₀₀₇ and adjust T₇₀₁₂ for maximum RF voltage (nom. 120 mVrms).

D. Reference Oscillator

Note:

Allow the transceiver to sit for one hour with the power OFF in a constant ambient temperature between 15 and 25°C. Then

switch the power ON and wait exactly 5 minutes before performing the following step.

Connect the frequency counter to TP₇₀₀₈ and adjust TC₇₀₀₁ for a reading of 30.000000 MHz, within a tolerance of +5 to -10 Hz.

E. 100 MHz VCO

1. Connect the DC voltmeter (10V range) to TP₇₀₀₅.
2. Adjust the main tuning knob to the point that provides the maximum voltage on the meter, and adjust T₇₀₀₁ so that this voltage is exactly 6V.
3. Check VCV operation by readjusting the main tuning knob for minimum voltage on the meter, which should be between 3.5 and 4.5V.

F. 20 MHz Bandpass Filter

Connect the RF voltmeter to TP₇₀₀₁ and adjust T₇₀₀₂ and T₇₀₀₃ for maximum RF voltage (nom. 18 mVrms).

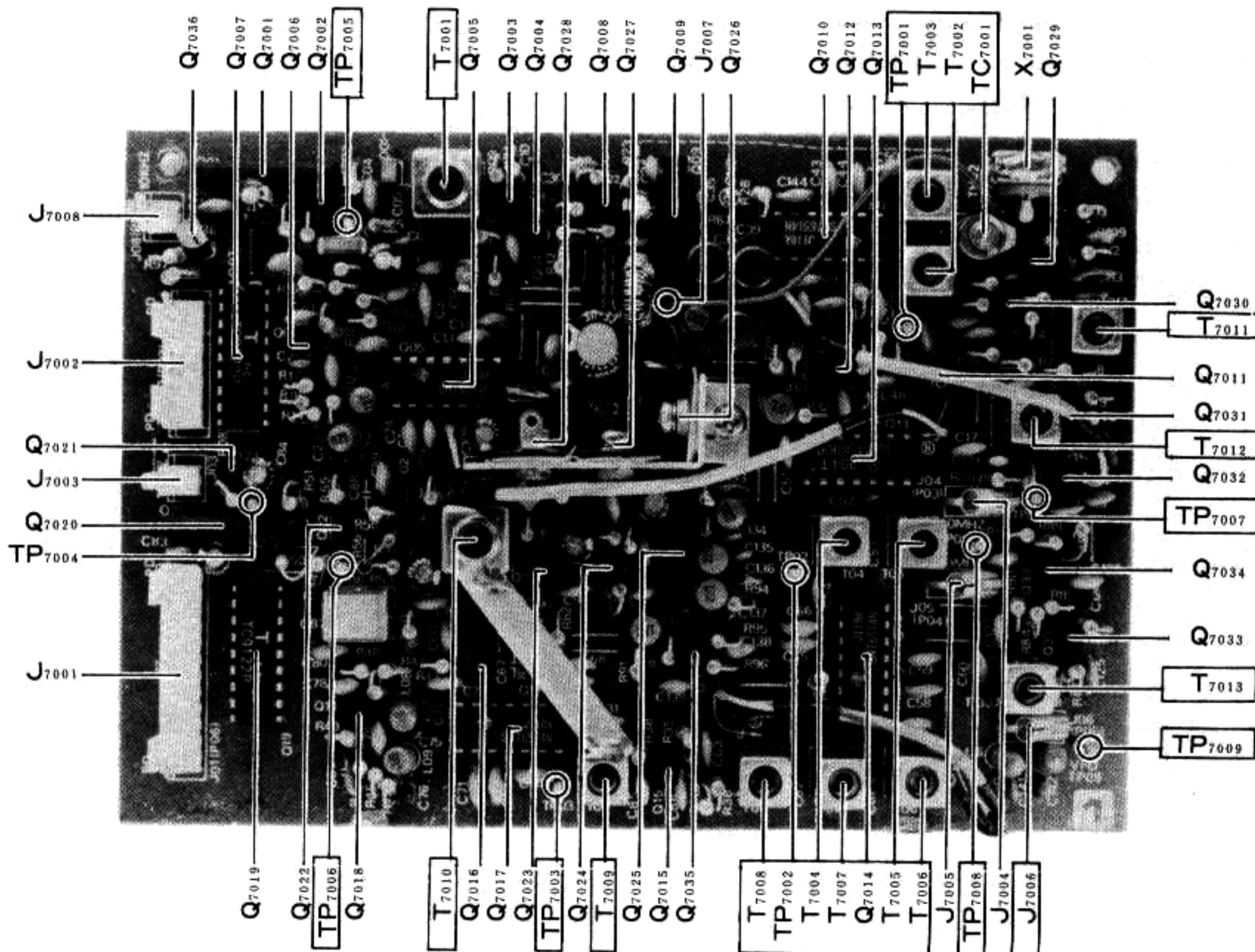

VFO UNIT

G. 2 MHz Bandpass Filter

Connect the RF voltmeter to TP₇₀₀₂ adjust T₇₀₀₄ and T₇₀₀₅ for maximum RF voltage (nom. 80 mVrms).

H. 62 MHz Bandpass Filter

1. Connect the spectrum analyzer (or test receiver) to TP₇₀₀₃ and tune to the signal at 62 MHz \pm 20 kHz.
2. Adjust T₇₀₀₆ - T₇₀₀₉ for peak signal strength, and then connect the RF voltmeter to verify that the signal level is at least 200 mVrms.

I. 55 MHz VCO

1. Connect the DC voltmeter to TP₇₀₀₆. Set the transceiver to USB and tune for a display of xx.499.99 MHz. Set the IF SHIFT control to the 12 o'clock position.
2. Adjust T₇₀₁₀ for an indication of 6.0V on the voltmeter, and check the VCV by tuning to xx.000.00 MHz. The voltmeter should now indicate 1.5-2.5V.

J. VFO Output Level Check

1. Remove P₀₅ from jack J₇₀₀₆, and connect a 50-ohm resistive load across the jack. Connect the RF voltmeter to TP₇₀₀₉.
2. Tune the main knob for maximum, and then minimum RF voltage indication, and calculate the voltage midway between these points, which should be in the range of 140 to 200 mVrms.
3. Calculate the differences between the midway voltage and the two measured extremes. These should each be less than 70 mV.

K. VFO Output Frequency Check

1. Connect the frequency counter to TP₇₀₀₉. Tune the transceiver for either xx.000.00 or xx.500.00 on the display, and ensure that the IF SHIFT control is centered.
2. Referring to the Table, check the counter reading in each mode and for each CW pitch in transmit.

3. Tune the transceiver one step (10 Hz) lower and recheck each mode and pitch for a 10 Hz decrease in counter reading.
4. Move the IF SHIFT control one step, and check for a 100 Hz shift on the counter.

VFO Output Table

	USB	LSB	FSK	AM, FM	CW-RX	CW-TX(PITCH)
xx.000.00 (xx.500.00)	MHz 4.98901	MHz 4.98601	MHz 4.98551	MHz 4.98751	MHz 4.98831	MHz 4.98881(500Hz); 4.98891(600Hz); 4.98901(700Hz)
xx.499.99 (xx.999.99)	MHz 5.48900	MHz 5.48600	MHz 5.48550	MHz 5.48750	MHz 5.48830	MHz 5.48880(500Hz); 5.48890(600Hz); 5.48900(700Hz)

PLL and VCO UNITS

A. 38.0675 MHz Crystal Oscillator

Remove P₃₅ from jack J₄₀₀₂, and connect a 50-ohm resistive load across the jack. Connect the RF voltmeter to J₄₀₀₂, and adjust T₄₀₀₁ for peak voltmeter deflection. Then rotate the core of T₄₀₀₁ one turn counterclockwise from the point of the peak.

B. PLL IF Passband

1. Connect the sweep generator to J₄₀₀₁, and the oscilloscope through the detector to TP₄₀₀₁.
2. Adjust the generator, and then T₄₀₀₃ and T₄₀₀₄, to obtain the passband shown below.

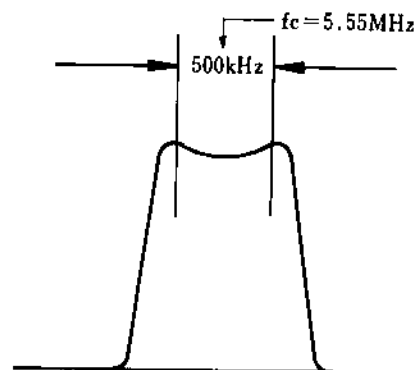

Passband Illustration

3. Move the oscilloscope connection to TP₄₀₀₂, and adjust T₄₀₀₅, T₄₀₀₇ and T₄₀₀₃ and T₄₀₀₄ (again, if necessary), for the passband illustrated.

RF UNIT

Bandpass Filter Alignment Table

A. Bandpass Filters

1. Connect the sweep generator to the ANT jack, and connect the oscilloscope through the detector to TP₁₀₀₁. Set the transceiver to the HAM VFO mode.
2. Referring to the accompanying Table, adjust the transformer pair corresponding to each band for the appropriate illustrated bandpass.

BAND	TRANS FORMER	ALIGNMENT PASSBAND	Passband Illustration
1.9MHz (160m)	T ₁₀₀₃ , T ₁₀₀₄	1.8-2.0 (MHz)	A
3.5MHz (80m)	T ₁₀₀₅ , T ₁₀₀₆	3.5-4.0	A
7MHz (40m)	T ₁₀₀₇ , T ₁₀₀₈	7.0-7.5	A
10MHz (30m)	T ₁₀₀₉ , T ₁₀₁₀	10.0-10.5	A
14MHz (20m)	T ₁₀₁₁ , T ₁₀₁₂	14.0-14.5	A
18MHz (17m)	T ₁₀₁₃ , T ₁₀₁₄	18.0-18.5	B
21MHz (15m)	T ₁₀₁₅ , T ₁₀₁₆	21.0-21.5	B
24.5MHz (12m)	T ₁₀₁₇ , T ₁₀₁₈	24.5-25.0	B
28MHz (10m)	T ₁₀₁₉ , T ₁₀₂₀	28.0-30.0	B

B. First IF Transformers

Set the MARKER switch on and tune the transceiver for peak S-meter deflection. Adjust T₁₀₂₉ and T₁₀₃₀ for peak S-meter deflection.

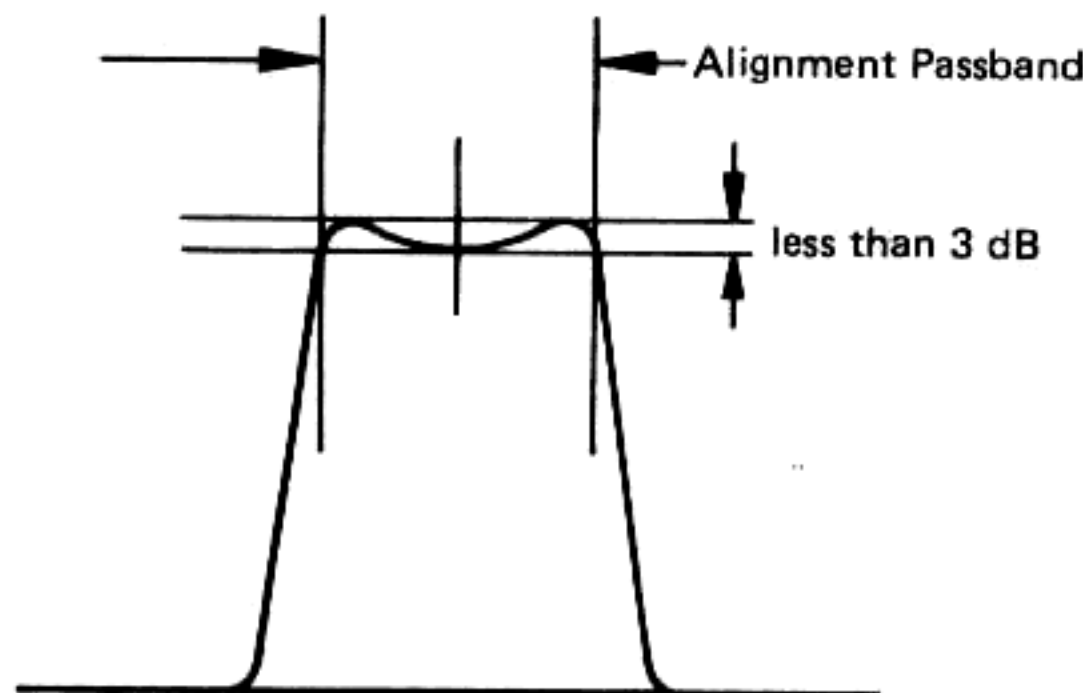

Passband Illustration A

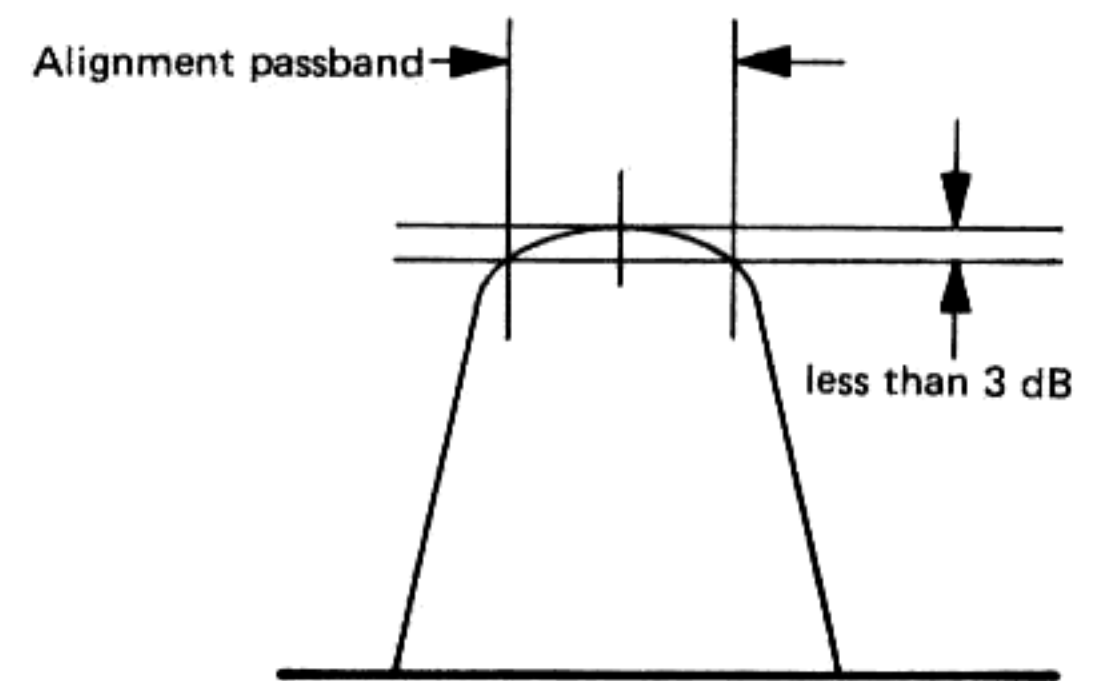

Passband Illustration B

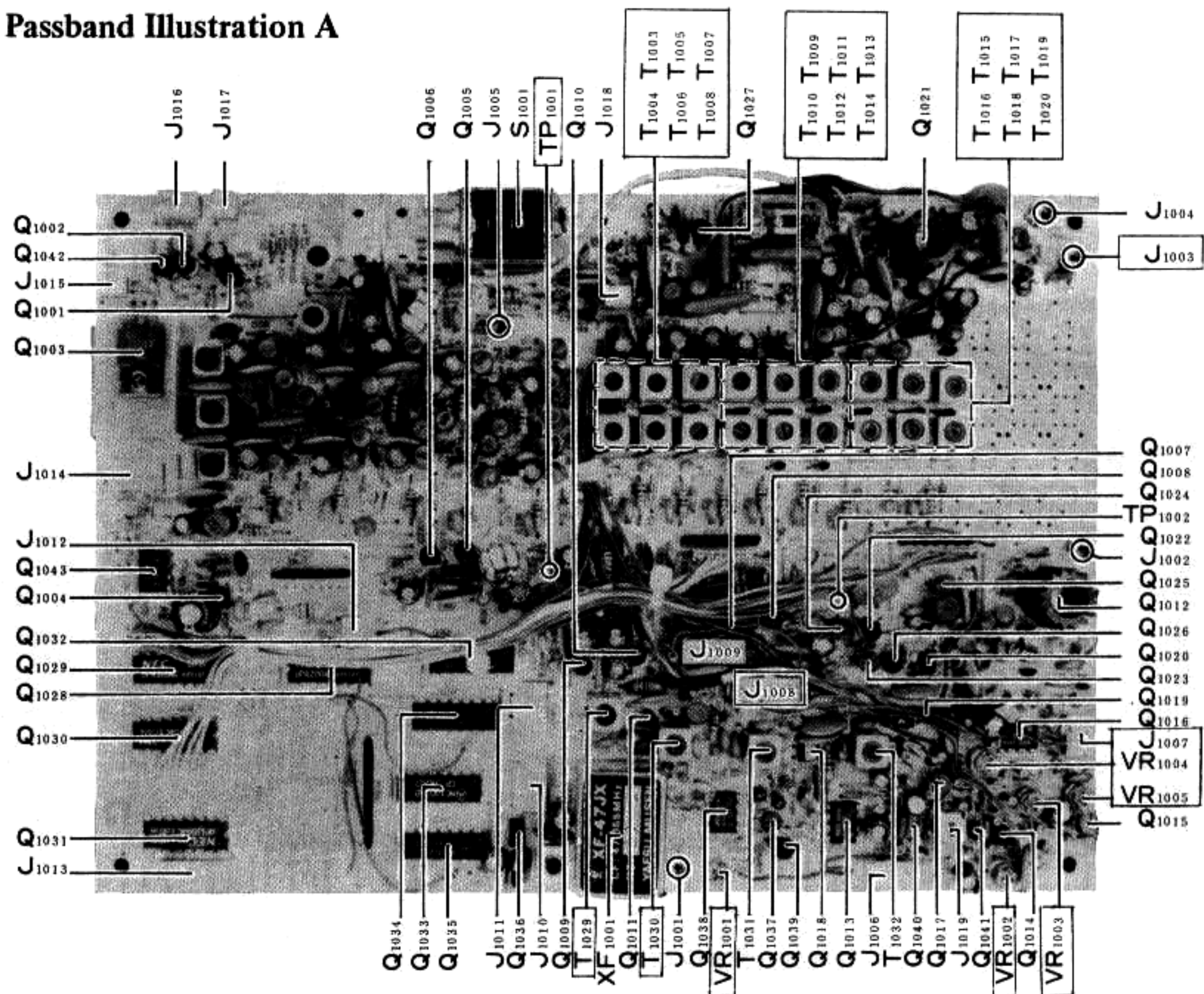

RF UNIT

IF UNIT

A. 2nd Local Buffer

Connect the RF voltmeter to TP₂₀₀₁ and adjust T₂₀₁₃ for maximum RF voltage (nom. 1 Vrms).

B. IF Width Oscillator and Buffer

1. Connect the RF voltmeter to TP₂₀₀₂ and adjust T₂₀₁₄ for maximum RF voltage (nom. 1 Vrms).
2. Connect the frequency counter to TP₂₀₀₂, and set the WIDTH control to the center detent. Adjust L₂₀₁₄ for 8.532500 MHz on the counter.

C. IF Transformers

Using the Marker signal, adjust T₂₀₀₁–T₂₀₀₉, T₂₀₁₃ and TC₂₀₀₁ for maximum S-meter deflection.

D. Noise Blanker IF

1. Connect the signal generator to the ANT jack, and the RF voltmeter to TP₂₀₀₄. Set the generator to the transceiver frequency, and output level between 30 and 50 dBμ. Adjust T₂₀₁₁ and T₂₀₁₂ for peak RF voltage on the meter.
2. Reduce the output level of the signal generator, and repeak T₂₀₁₁ and T₂₀₁₂ for maximum RF voltage.

E. FM IF Transformer

With the signal generator connected as above, again set for 30–50 dBμ output. Connect the RF voltmeter to TP₂₀₀₃ and adjust T₂₀₁₀ for peak RF voltage. Reduce the generator output if saturation occurs.

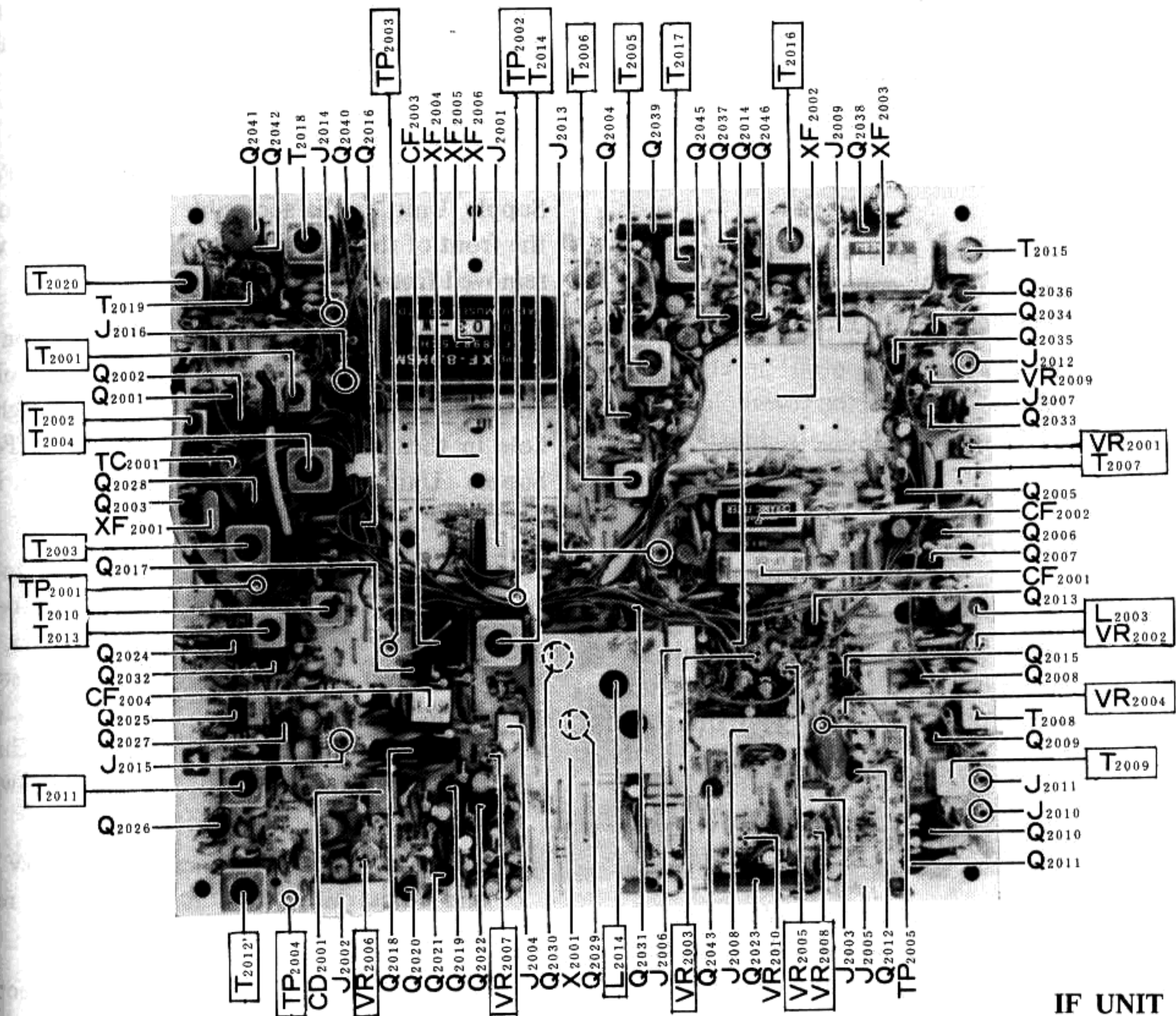

IF UNIT

F. Notch

1. With the transceiver set to USB and the NOTCH control set to the 12 o'clock position, switch the Marker on and tune for a heterodyne of 1500 Hz.
2. Turn the NOTCH switch ON and adjust L₂₀₀₃ for minimum deflection on the S-meter.

G. Squelch Preset

Set the transceiver to FM, and the SQL control to the 10 o'clock position. With no equipment connected to the ANT jack, adjust VR₂₀₀₆ just to the point where the noise is squelched.

H. IF System Gain

1. Set the transceiver to the HAM VFO mode, 14 MHz. Preset VR₂₀₀₄ to the threshold point where the S-meter just begins to deflect with no signal input at the ANT jack.
2. Connect the signal generator to the ANT jack, and set for an output level of 10 dB μ at the transceiver frequency. Adjust VR₂₀₀₁ for S-1 deflection on the S-meter.

I. RF AGC

1. With the same signal generator setup as in the preceding step (H.2), connect the DC voltmeter (impedance > 1 Megohm) to TP₂₀₀₅.
2. Set the signal generator output level to 70 dB μ , and adjust VR₂₀₀₃ to the threshold point where the DC voltmeter indication just begins to fall.

J. S-Meter Sensitivity

1. With the same signal generator set up as in step H.2 above, set the generator output to 80 dB μ and adjust VR₂₀₀₅ so that the S-meter deflects to the full scale mark (S9+40 dB).
2. Repeat procedures H and J several times.

K. DISC Meter Calibration

1. With the transceiver set to FM and no connections to the ANT jack, adjust VR₂₀₀₈ so that Meter I deflects exactly to the center of the scale.

2. Switch the Marker ON, and adjust VR₂₀₀₇ so that when the transceiver is tuned up and down slightly, the meter deflects to both edges of the scale. Switch the Marker OFF.
3. Repeat steps 1 and 2 several times.

AF UNIT

A. BFO/Width Mixer

With the WIDTH and SHIFT controls centered, connect the RF voltmeter to TP₃₀₀₁ and adjust T₃₀₀₃ for maximum RF voltage (nom. 700 mVrms).

B. RX Carrier Balance

With the transceiver set to USB and the Marker ON, tune for about a 1 kHz beat. Connect the AF voltmeter across the speaker terminals, and adjust VR₃₀₀₅ for maximum AF voltage.

POWER SUPPLY

The Power Supply should not require adjustment except in the event of failure of one of the components affecting voltage regulation.

24V potentiometer VR₂₀₁ is located on the 24V AVR Unit at the inside bottom front of the Power Supply Unit, and is accessible through the hole in the front of the Power Supply Unit enclosure when removed from the FT-980 Main Chassis.

13.5V potentiometer VR₃₀₁ is located on the 13.5V AVR Unit at the inside bottom rear of the Power Supply Unit, and is accessible through the hole in the grill at the bottom rear of the Power Supply Unit, without removal from the Main Chassis.

1. To adjust the 24V regulator, refer to Exploded View 2 on page 99, and remove the six screws affixing the heatsink cover, and the cover. Then remove the four screws between the fins of the Power Supply heatsink affixing the Unit in the Main Chassis, and remove the Unit, leaving the wiring connected.

Connect the DC voltmeter to the 24V bus, and adjust VR₂₀₁ for 24V DC during reception.

2. To adjust the 13.5V regulator, connect the DC voltmeter to the 13.5V bus and adjust VR₃₀₁ for 13.5V during reception.

R₂₀₀₇ SO
up and
to both
OFF.

ols cen-
TP₃₀₀₁
voltage

and the
Hz beat.
speaker
maximum

ustment
of the

he 24V
e Power
hole in
re when

on the
of the
ugh the
Power
e Main

to Ex-
ve the
er, and
screws
y heat-
chassis,
wiring

V bus,
recep-

ct the
adjust

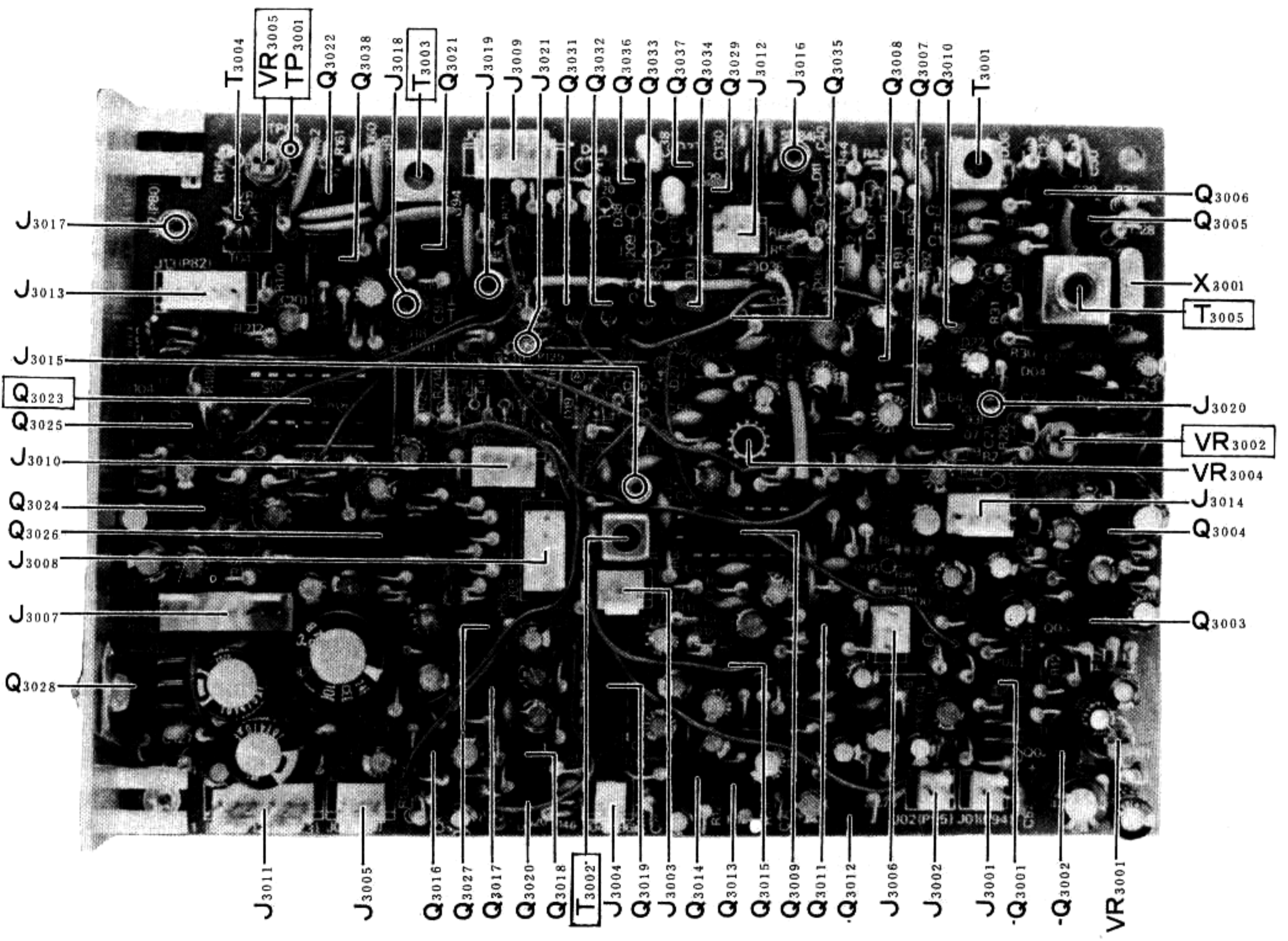

AF UNIT

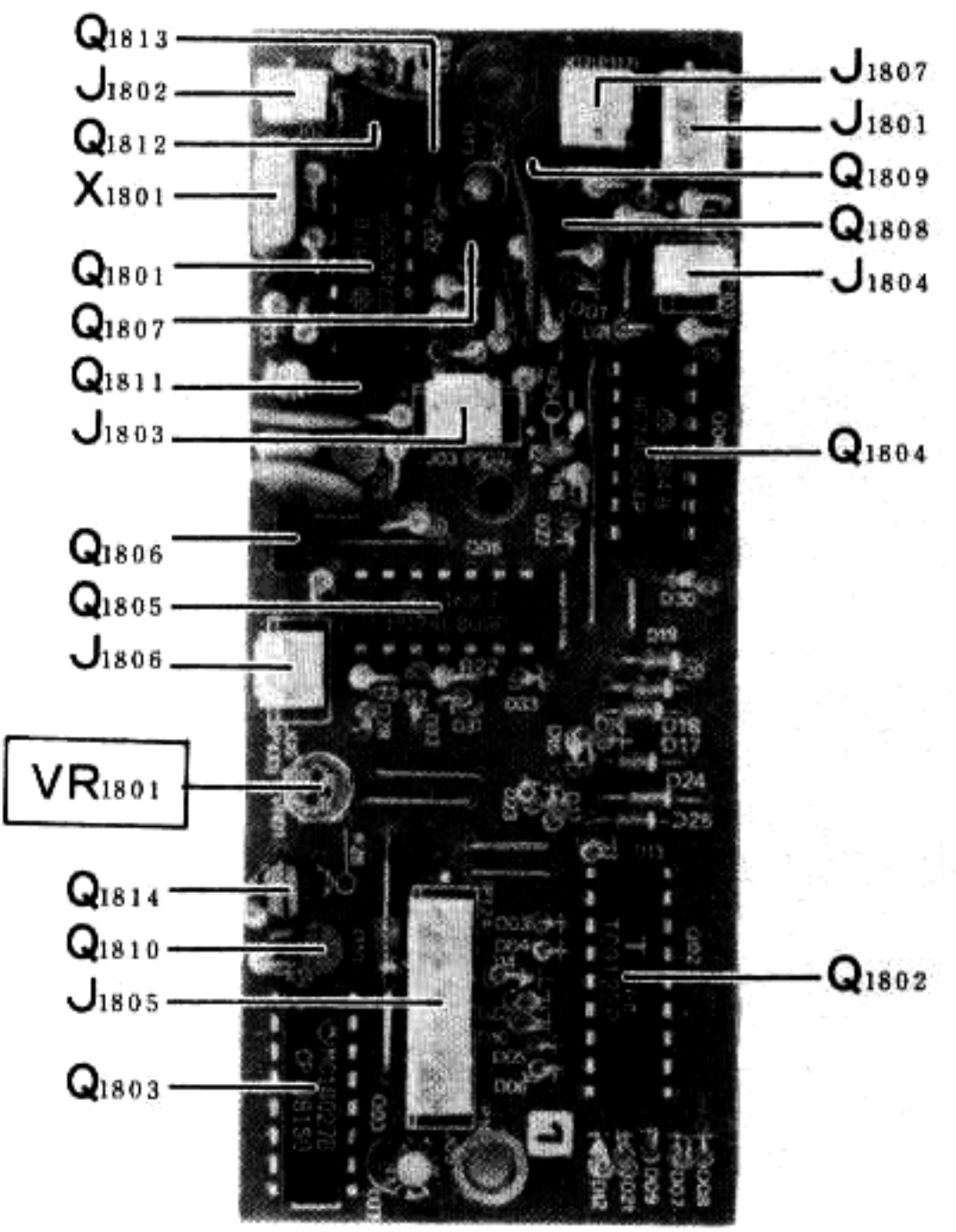

FSK UNIT

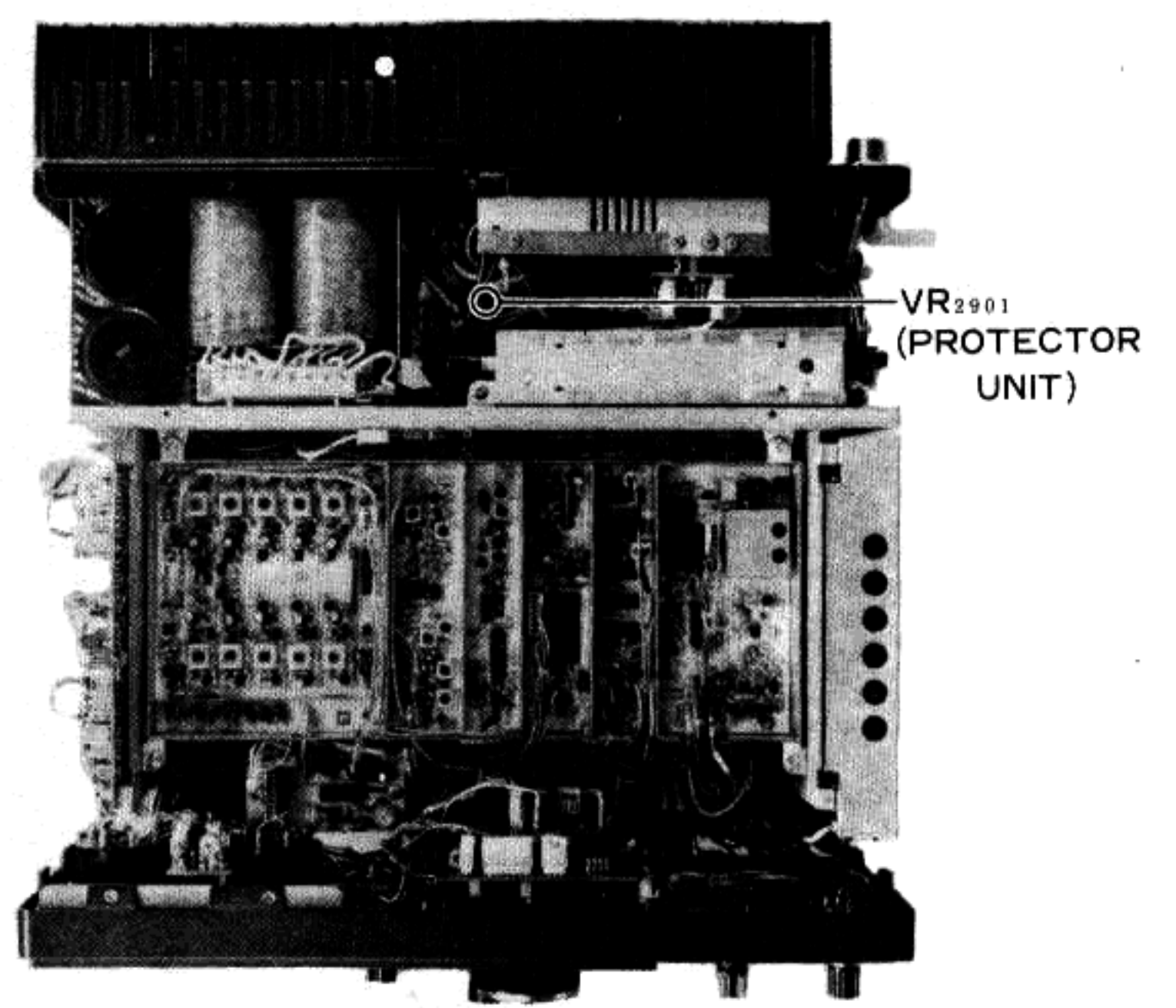

TOP VIEW

TRANSMITTER

The following procedures are interdependent, and may require that previous procedures be performed before, or again after each. Therefore, the entire transmitter section should be performed from beginning to end if one adjustment is required. All frequency measurements are to be made with the transceiver set to the HAM VFO. Except where specifically stated otherwise, the 50-ohm dummy load must be connected to the ANT jack for every step.

A. TX IF Transformers

1. Preset the FSK output level adjustment VR₁₈₀₁ on the FSK Unit fully clockwise. Disconnect P₆₅ from J₁₀₀₃ on the RF Unit, and connect a 50-ohm resistive load along with the RF voltmeter across RF OUT jack J₁₇ on the rear panel.
2. Preset the DRIVE control and VR₁₀₀₄ on the RF Unit fully clockwise, and preset VR₁₀₀₂ and VR₁₀₀₃ (RF Unit) and VR₂₉₀₁ (Protector Unit) fully counterclockwise. Tune the transceiver to 14 MHz, FSK mode.
3. Close the PTT line and adjust T₃₀₀₂ (AF Unit) for maximum RF voltage on the meter. Then adjust T₂₀₁₅, T₂₀₁₈ and T₂₀₂₀ (IF Unit); and T₁₀₃₁ and T₁₀₃₂ (RF Unit), also for maximum RF voltage on the meter.

B. Carrier Balance

Set the transceiver to LSB, and the MIC GAIN control fully counterclockwise. With the same connections as above, adjust VR₃₀₀₄ (AF Unit) for minimum RF voltage on the meter.

C. ALC Level

1. Reconnect P₆₅ to J₁₀₀₃ (RF Unit), and connect the wattmeter along with the dummy load to the ANT jack. With the DRIVE control and VR₁₀₀₄ (RF Unit) preset fully clockwise, also set VR₁₀₀₃ fully clockwise. VR₂₉₀₁ on the Protector Unit must remain fully counterclockwise.
2. With the transceiver tuned to 14 MHz, FSK mode, close the PTT line and adjust VR₁₀₀₃ (RF Unit) for 70W on the wattmeter.
3. Repeat step 2 with the transceiver tuned to 28 MHz, adjusting VR₁₀₀₂ for 100W on the wattmeter.

D. Protector Current Limiter

Tune the transceiver to 1.9 MHz. With the DRIVE control still fully clockwise, close the PTT line and adjust VR₂₉₀₁ (Protector Unit) for 100W on the wattmeter.

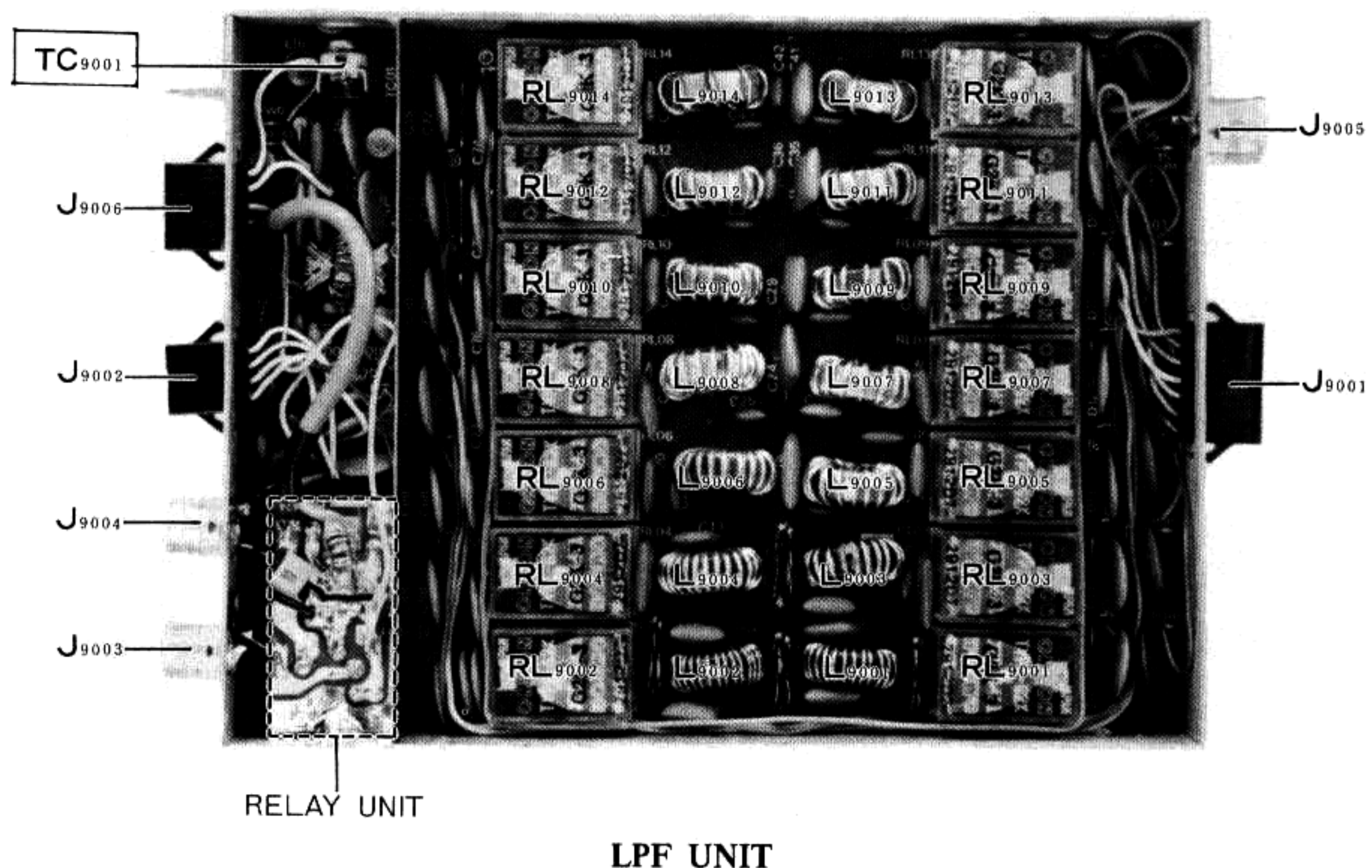

E. CM Coupler Balance

1. Connect the DC voltmeter to pin 1 of J₁₀₀₇ (RF Unit), and with the same setup as above, close the PTT line and adjust TC₉₀₀₁ (Relay Unit) for maximum DC voltmeter indication.
2. Repeat steps C.2 and C.3 in the ALC Level procedure above.

F. Reverse ALC Level

With the transceiver set to 14 MHz, FSK, connect a 17-ohm dummy load (three 50-ohm loads in parallel) with the in-line wattmeter to the ANT jack. Close the PTT line and adjust VR₁₀₀₄ (RF Unit) for 80W output.

G. ALC Meter Sensitivity

1. Remove the previous connections to the ANT jack, and reconnect the wattmeter and 50-ohm load. Set the transceiver to 14 MHz, USB, and the ALC METER switch to NORMAL. Set the MIC GAIN control to midrange, and connect the AF generator to the MIC jack. Set the generator output for 1 kHz, at the level that is just sufficient to cause the ALC meter to begin to deflect, and then increase the generator output exactly 10 dB.
2. Adjust VR₁₀₀₁ (RF Unit) so that the ALC meter indicates to the right edge of the ALC zone (corresponding with the S-9+10dB mark on the S-Unit scale).

H. FSK Output Level

Switch to the FSK mode, and with the DRIVE control fully clockwise, close the PTT line and adjust VR₁₈₀₁ (FSK Unit) for the same ALC meter indication as in the preceding step.

I. AM Modulation

1. Switch to the AM mode, and connect the monitor scope to the ANT jack with the dummy load and wattmeter. Close the PTT line and adjust the DRIVE control for 25W output.
2. Adjust the 1 kHz output of the AF generator to 1.5 mVrms, and set the MIC GAIN control fully clockwise.

3. Connect the DC voltmeter to pin 5 of J₁₀₀₉ (RF Unit), and adjust VR₁₀₀₅ for 4.0V DC.
4. Increase the AF generator level to 10 mV, and check the output waveform for undistorted modulation. Then reduce the generator level until the monitor scope indicates 60% modulation, and check that the generator signal applied to the MIC jack is less than 2 mV.

J. Speech Processor

1. With the transceiver set to 14 MHz, USB, set the DRIVE control fully clockwise, and the COMP control to midrange.
2. Set the AF generator for 1 mV output (at 1 kHz), and slightly adjust the COMP control to the threshold point just before the ALC meter begins to deflect.
3. Adjust T₂₀₁₇ (IF Unit) for maximum power output on the wattmeter, and set the COMP control so that the COMP meter indicates 1 dB. Adjust T₂₀₁₆ for maximum deflection on the COMP meter.

K. FM Modulator

1. Install the RF sampling coupler in the line between the ANT jack and dummy load, and connect the deviation meter to the sampling port. Couple the frequency counter to the RF OUT terminal on the rear panel, and set the transceiver to 28 MHz, FM mode.
2. Adjust T₃₀₀₅ (AF Unit) to obtain the same frequency on the display as that on the counter.
3. Preset VR₃₀₀₂ fully clockwise, and with the AF generator set for 1 mVrms at 1 kHz to the MIC jack, adjust VR₃₀₀₁ for ±3.5 kHz deviation.
4. Increase the generator output to 10 mVrms, and adjust VR₃₀₀₂ for ±5 kHz deviation.

L. PO Meter Calibration

Adjust the DRIVE control for 100W output on the external wattmeter, and adjust VR₁₁ for the same indication on Meter I (make sure the dummy load is 50 ohms).

M. IC and VCC Meter Calibration

1. Connect the ammeter in series with the high-current line to the PA Unit, and adjust VR₁₉₀₂ (REG Unit) so that the indication on Meter I matches the ammeter.
2. Connect the DC voltmeter between the high-current line to the PA Unit and ground, and adjust VR₃₆₀₁ on the Monitor Unit to match the VCC indication on Meter I with the voltmeter.

N. Final Amplifier Bias

Replace the ammeter in the high-current line to the PA Unit with the milliammeter, and without keying the transmitter, adjust VR₈₀₀₁ (PA Unit) for 200 mA.

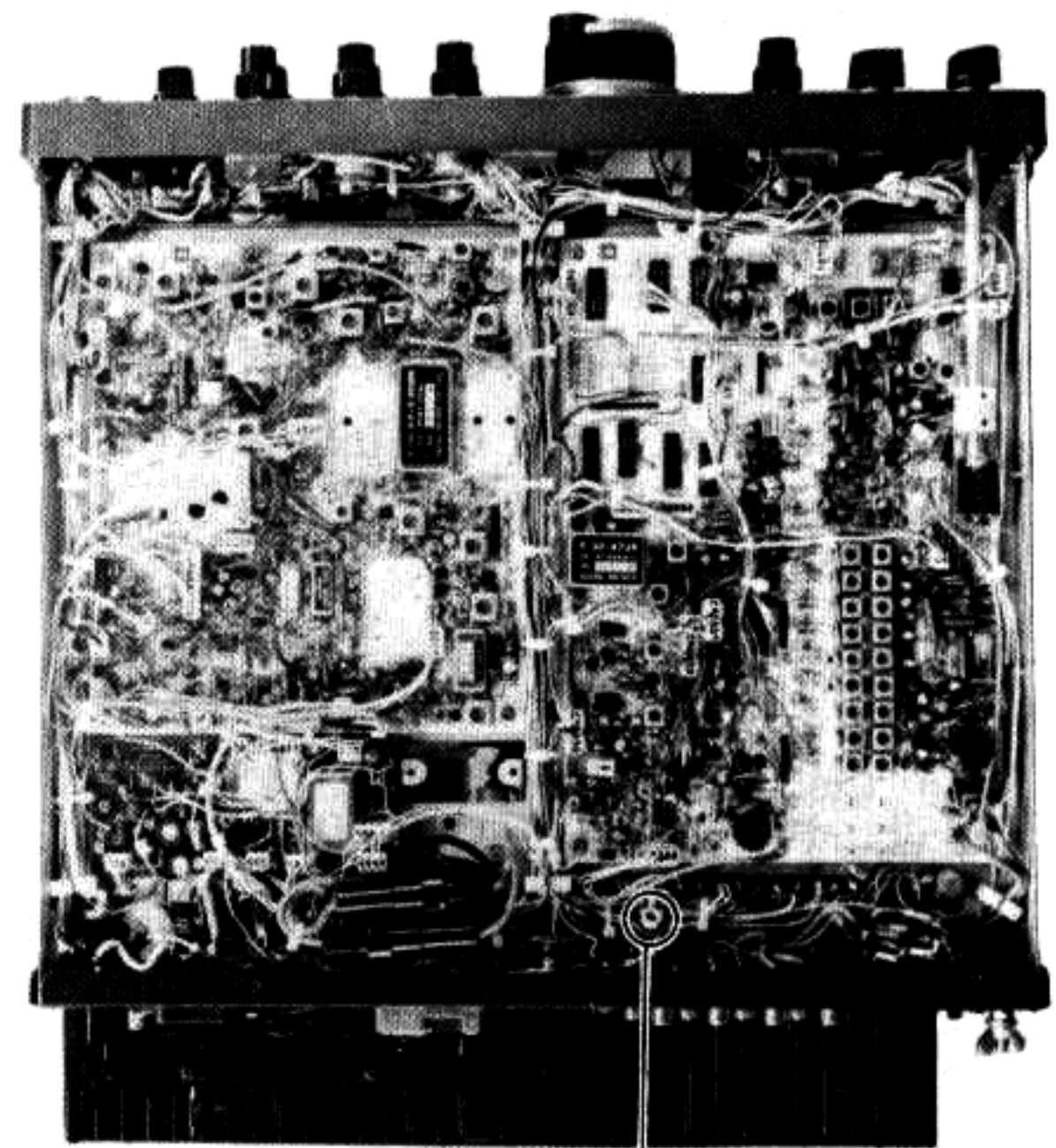

VR₁₁ PO Set

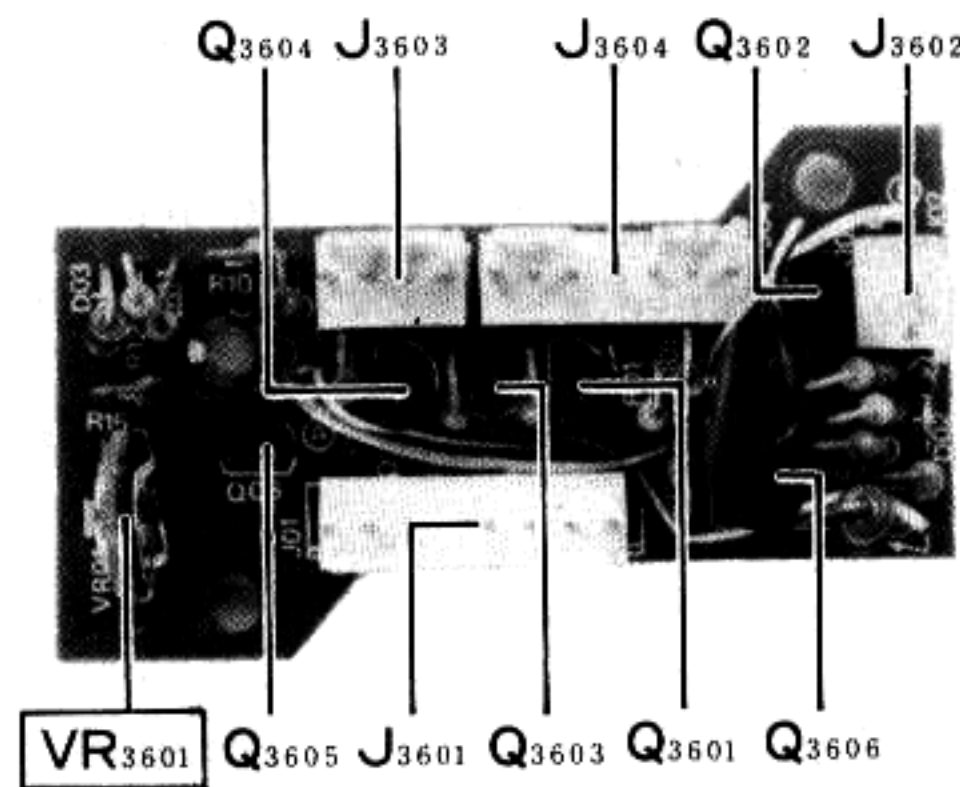

TOP VIEW

MONITOR UNIT

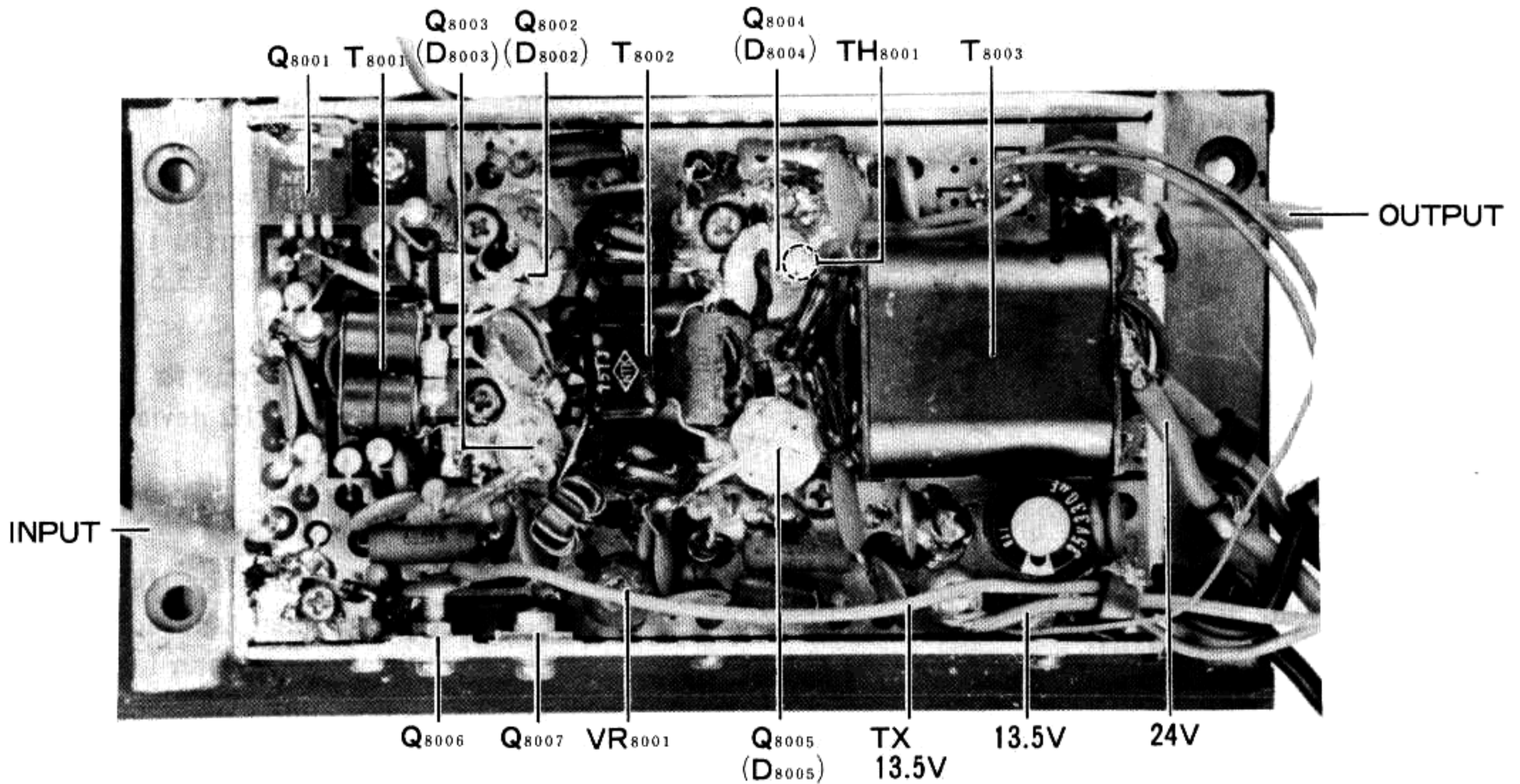

PA UNIT

COMPONENT APPLICATIONS

MAIN CHASSIS

Part No.	Device	Type	Function
Q1	2SA1012Y	Transistor	Regulator (+9V Line)
Q2	2SC8800	"	" (Display Unit +9V Line)
Q3	μPC7808	IC	" (for Meter Lamp)
Q4	2SB856	Transistor	" (CPU Unit +5V Line)
D1	1SS53	Si Diode	Marker Control Switch
D2	"	"	"
D3	"	"	CW Full Break-in Switch
D4	"	"	Back Pulse Cancelling

RF UNIT

Part No.	Device	Type	Function
Q1001	2SA733AP	Transistor	TX PA Disable Switch
Q1002	2SC1815Y	"	"
Q1003	2SA1012Y	"	"
Q1004	2SC1815GR	"	TX PO Meter Amplifier
Q1005	2SK125	JFET	RX RF Amplifier (GEN)
Q1006	"	"	" (")
Q1007	"	"	" (HAM)
Q1008	"	"	" (")
Q1009	"	"	RX 1st Mixer
Q1010	"	"	"
Q1011	"	"	RX Post Amplifier
Q1012	2N4427	Transistor	RX 1st Local (TX 2nd Local) Amplifier
Q1013	μPC1458C	IC	TX ALC Meter Amplifier
Q1014	2SA733AP	Transistor	TX Power Controller (AM, 10m)
Q1015	2SC1815GR	"	TX AM ALC Amplifier
Q1016	μPC1458C	IC	TX ALC Amplifier
Q1017	2SC1815GR	Transistor	"
Q1018	3SK73GR	MOS FET	TX 1st IF Amplifier
Q1019	ND487C2-3R	IC (Ring Module)	TX 2nd Mixer
Q1020	2SK125	JFET	TX RF Amplifier
Q1021	2N4427	Transistor	TX Predriver Amplifier
Q1022	2SC1959Y	"	TX Predriver (Q1021) Bias Switch
Q1023	2SC1815Y	"	KEY Switch
Q1024	"	"	TX Unlock Switch
Q1025	2SA733AP	"	"
Q1026	"	"	TX RF Amplifier (Q1020) Bias Switch
Q1027	"	"	Relay Driver [GEN/HAM Relay (RL1001)]
Q1028	μPA2004C	IC	Driver Array (for GEN/HAM Relay, GEN BPF Selector)
Q1029	"	"	" (HAM BPF Selector)
Q1030	"	"	" (")
Q1031	"	"	" [LPF Relay (RL9001-9014) Driver]
Q1032	MC14028B	"	Decoder (Filter Selector)
Q1033	"	"	" (")
Q1034	MC14081B	"	AND Gate (")
Q1035	"	"	" (")
Q1036	μPC78L05	"	Regulator (for Filter Select Logic Circuit)

Q1037	2SK107-3	JFET	TX ALC Meter Peak Hold Controller
Q1038	μPC1458C	IC	TL ALC Meter Amplifier and TX ALC Meter Peak Hold Controller
Q1039	2SC1815Y	Transistor	TX ALC Meter Peak Hold Controller
Q1040	2SA733AP	"	TX DRIVE Level Controller (SSB, PROC. ON)
Q1041	2SC1815Y	"	TX Power Controller (AM, 10m BAND)
Q1042	"	"	TX PA Disable Switch
Q1043	AN6552	IC	TX FWD, REF Meter Amplifier
D1001	1SS53	Si Diode	Diode OR (for Transverter Control at ACC-1)
D1002	"	"	"
D1003	"	"	"
D1004	"	"	"
D1005	HZ5C-2	Zener Diode	Regulator [for TX PA Disable Switch (Q1001)]
D1006	1SS97	Schottky Barrier Di.	BPF Switch (GEN, 0.15-1 MHz)
D1007	"	"	" (")
D1008	"	"	" (GEN, 1-2 MHz)
D1009	"	"	" (")
D1010	"	"	" (GEN, 2-4 MHz)
D1011	"	"	" (")
D1012	"	"	" (GEN, 4-8 MHz)
D1013	"	"	" (")
D1014	"	"	" (GEN, 8-16 MHz)
D1015	"	"	" (")
D1016	"	"	" (GEN, 16-30 MHz)
D1017	"	"	" (")
D1018	1SS53	Si Diode	Diode OR (RX ON)
D1019	"	"	" (TX ON)
D1020	"	"	" (RX ON)
D1021	1SS55	"	" (TX ON)
D1022	1SS53	"	BPF Switch (HAM, 160m)
D1023	1SS97	Schottky Barrier Di.	" (")
D1024	1SS53	Si Diode	" (HAM, 80m)
D1025	1SS97	Schottky Barrier Di.	" (")
D1026	1SS53	Si Diode	" (HAM, 40m)
D1027	1SS97	Schottky Barrier Di.	" (")
D1028	1SS53	Si Diode	" (HAM, 30m)
D1029	1SS97	Schottky Barrier Di.	" (")
D1030	1SS53	Si Diode	" (HAM, 20m)
D1031	1SS97	Schottky Barrier Di.	" (")
D1032	1SS53	Si Diode	" (HAM, 17m)
D1033	1SS97	Schottky Barrier Di.	" (")
D1034	1SS53	Si Diode	" (HAM, 15m)
D1035	1SS97	Schottky Barrier Di.	" (")
D1036	1SS53	Si Diode	" (HAM, 12m)
D1037	1SS97	Schottky Barrier Di.	" (")
D1038	1SS53	Si Diode	" (HAM, 10m)
D1039	1SS97	Schottky Barrier Di.	" (")
D1040	1SS53	Si Diode	" (HAM, AUX)
D1041	1SS97	Schottky Barrier Di.	" (")
D1042	1SS53	Si Diode	" (")
D1043	1SS97	Schottky Barrier Di.	" (")
D1044	1SS53	Si Diode	" (")
D1045	1SS97	Schottky Barrier Di.	" (")
D1046	"	"	" (HAM, 160-17m)
D1047	"	"	" (HAM, 15-10m, AUX)
D1048	1SS53	Si Diode	GEN/HAM Selector (GEN)
D1049	"	"	" (HAM)

D1050	1SS53	Si Diode	T/R Switch (RX ON)
D1051	"	"	Reverse Voltage Protector (for Q1038)
D1052	HZ9C1	Zener Diode	TX ALC Clipper
D1053	Not Used		
D1054	HZ9C1	Zener Diode	TX REV ALC Clipper
D1055	1SS97	Schottky Barrier Di.	ALC Meter Peak Hold Switch
D1056	"	"	"
D1057	1SS53	Si Diode	Switch (TX FWD ALC)
D1058	"	"	" (TX REV ALC)
D1059	MV103	Varistor Diode	Temperature Compensator (for TX ALC Amplifier Q1017)
D1060	Not Used		
D1061	1SS53	Si Diode	T/R Switch (TX ON)
D1062	"	"	TX RF Amplifier (Q1020) Bias Switch
D1063	"	"	TX Predriver Bias Switch (Q1022) Delay Control
D1064	"	"	Reverse Voltage Protector (for Q1027)
D1065	"	"	12m TX Disable Switch
D1066	"	"	17m TX Disable Switch
D1067	Not Used		
D1068	1SS53	Si Diode	Diode Matrix (Filter Select Data)
D1086	1SS53	Si Diode	Diode Matrix (Filter Selector Data)
D1087	"	"	TX Unlock Switch
D1088	"	"	
D1089	"	"	Switch (TX ALC 1 Line)
D1090	"	"	Compensation for Q1040
D1091	"	"	TX AM ALC Switch
D1092	"	"	Reverse Voltage Protector (for Q1043)
D1093	"	"	" (")
XF1001	XF-47JX	Crystal Filter	RX 1st IF Filter, TX 2nd IF Filter

IF UNIT

Part No.	Device	Type	Function
Q2001	2SK19TM-GR	JFET	RX 2nd Mixer
Q2002	"	"	"
Q2003	2SC380Y	Transistor	RX NB Buffer Amplifier
Q2004	3SK73GR	MOS FET	RX 3rd Mixer (SSB, AM, CW, FSK)
Q2005	"	"	RX 3rd IF Amplifier (")
Q2006	2SC1815Y	Transistor	RX Q Multiplier
Q2007	"	"	"
Q2008	2SC1815BL	"	RX 3rd IF Buffer Amplifier
Q2009	3SK73GR	MOS FET	RX 3rd IF Amplifier (SSB, AM, CW, FSK)
Q2010	2SC1815Y	Transistor	RX 3rd IF Buffer Amplifier (AM, 3rd IF AGC)
Q2011	"	"	"
Q2012	2SC1815GR	"	RX 3rd IF AGC Controller
Q2013	2SC1815Y	"	RX 3rd IF Buffer Amplifier (RF AGC)
Q2014	"	"	RX RF AGC Controller
Q2015	μPC1458C	IC	RX S-Meter Amplifier
Q2016	3SK73GR	MOS FET	RX 3rd Mixer (for FM)
Q2017	2SC1815Y	Transistor	RX 3rd IF Amplifier (")
Q2018	μPC577H	IC	" (")

Q2019	2SC1815Y	Transistor	RX AF Amplifier (FM)
Q2020	"	"	RX FM SQL Amplifier
Q2021	"	"	"
Q2022	"	"	RX FM SQL Switch
Q2023	AN6551	IC	RX FM Center Meter DC Amplifier and RX WIDTH Controller (for EXT Control)
Q2024	2SC1583G	Transistor	RX NB Amplifier
Q2025	"	"	"
Q2026	2SC380Y	"	"
Q2027	2SC1815Y	"	RX NB AGC Amplifier
Q2028	2SC1815GR	"	RX NB Switch
Q2029	2SC380Y	"	RX WIDTH VCXO
Q2030	"	"	RX WIDTH Buffer Amplifier
Q2031	2SC1959Y	"	"
Q2032	2SC1923R	"	RX 2nd Local (TX 1st Local) Amplifier
Q2033	2SC1815GR	"	TX AMGC Switch
Q2034	2SB774	"	"
Q2035	2SC1815GR	"	"
Q2036	2SK125	JFET	TX AMGC Controller
Q2037	2SC380Y	Transistor	TX 1st IF Amplifier (for COMP Meter)
Q2038	2SC1815GR	"	TX COMP Meter DC Amplifier
Q2039	TA7302P	IC	TX 1st IF Limiter Amplifier (PROC ON)
Q2040	2SA733AP	Transistor	TX 1st IF Filter Switch (SSB Mode)
Q2041	3SK73GR	MOS FET	TX 1st Mixer
Q2042	"	"	"
Q2043	2SC1815GR	Transistor	WIDTH Controller Select Relay (RL2001) Driver
Q2044	Not Used		
Q2045	2SA733AP	Transistor	TX PROC ON/OFF Switch (PROC ON)
Q2046	"	"	" (PROC OFF)
D2001	1SS53	Si Diode	T/R Switch (RX 1st IF ON)
D2002	1SS97	Schottky Barrier Di.	RX NB Gate
D2003	"	"	"
D2004	1SS53	Si Diode	RX 3rd IF Filter Switch (AM-W)
D2005	"	"	" (SSB, FSK, AM-N, CW)
D2006	"	"	" (CW-N)
D2007	"	"	" (AM-W)
D2008	"	"	" (SSB, FSK, AM-N, CW)
D2009	"	"	" (CW-N)
D2010	"	"	Filter Selector (SSB)
D2011	"	"	" (CW-W)
D2012	"	"	" (AM-N)
D2013	1SV55	Varactor Diode	RX NOTCH Filter Rejection Frequency Controller
D2014	1SS16	Schottky Barrier Di.	Threshold Level Compensator (for AM Detector)
D2015	1N60	Ge Diode	RX AM Detector
D2016	"	"	RX 3rd IF AGC Detector
D2017	"	"	"
D2018	1N270	"	RX RF AGC Detector
D2019	"	"	"
D2020	1SS53	Si Diode	Reverse Voltage Protector (for Q2015)
D2021	1N60	Ge Diode	RX FM Discriminator
D2022	"	"	"
D2023	"	"	RX FM Noise Detector
D2024	1SS53	Si Diode	Threshold Level Compensator (for RX FM Noise Detector)
D2025	1S188FM	Ge Diode	RX FM Noise Detector
D2026	1SS53	Si Diode	Reverse Voltage Protector (for Q2023)
D2027	1N60	Ge Diode	RX NB Detector
D2028	"	"	"

D2029	1S1555	Si Diode	RX NB Switch
D2030	1SV50	Varactor Diode	RX WIDTH VCXO
D2031	1N60	Ge Diode	TX AMGC Detector
D2032	"	"	"
D2033	1SS53	Si Diode	Switch (RX 9V for AMGC)
D2034	1N60	Ge Diode	TX COMP Meter Detector
D2035	"	"	"
D2036	1SS53	Si Diode	Logarithmic Compensator (for COMP Meter)
D2037	"	"	PROC Switch (PROC ON)
D2038	"	"	" (PROC OFF)
D2039	"	"	" (")
D2040	"	"	" (PROC ON)
D2041	"	"	T/R Switch (RX 3rd IF ON)
D2042	"	"	Filter Selector (CW-W)
D2043	"	"	" (CW-N)
D2044	"	"	" (AM-W)
D2045	"	"	" (AM-N)
D2046	1SS97	Schottky Barrier Di.	RX 2nd Filter Switch (AM)
D2047	"	"	" (SSB, FSK, CW)
D2048	"	"	" (CW-W)
D2049	"	"	" (AM)
D2050	"	"	" (SSB, FSK, CW)
D2051	"	"	" (CW-W)
D2052	1SS53	Si Diode	T/R Switch (RX 2nd IF ON)
D2053	"	"	TX 1st IF Filter Switch (SSB)
D2054	"	"	" (")
D2055	"	"	" (")
D2056	"	"	T/R Switch (TX 2nd IF ON)
D2057	"	"	" (TX ON for CW, AM, FM)
D2058	"	"	" (" " ")
D2059	"	"	Reverse Voltage Protector (for Q2043)
D2060	FC63	Varactor Diode	RX NB Gate
D2061	1SS53	Si Diode	Diode OR (RX 9V for FM)
D2062	"	"	Threshold Level Compensator (for TX COMP Meter DC
D2063	"	"	Filter Selector (SSB) Amplifier Q1038)
D2064	"	"	" (CW-N)
D2065	"	"	RX FM 3rd Mixer (Q2016) Disable Switch (SSB, FSK, CW, AM)
D2066	1N270	Ge Diode	RX RF AGC Detector
D2067	1SS53	Si Diode	Diode OR (FM 9V for FM)
D2068	Not Used		
D2069	"		
D2070	HZ7A2	Zener Diode	Regulator (TX 1st IF Switching Stabilizer)
D2071	1SS53	Si Diode	Reverse Voltage Protector (for Q2046)
X2001	8532.5kHz	Crystal (HC-18/U)	RX WIDTH VCXO
TH2001	SDT-250	Thermistor	Temperature Compensator (for RX FM SQL Switch)
XF2001	8.9M20A	Crystal Filter	RX 2nd IF Filter
XF2002	XF-455.8MCN	"	RX 3rd IF Filter (CW-N; OPTION)
XF2003	XF-8.9LP	"	TX SSB Filter
XF2004	XF-8.9GA	"	RX 2nd IF Filter (AM; OPTION)
XF2005	XF-8.9HSM	"	RX 2nd (TX 1st) IF Filter (SSB, FSK, CW)
XF2006	XF-8.9HC	"	RX 2nd IF Filter (CW-W; OPTION)

CF2001	CFM-455H	Ceramic Filter	RX 3rd IF Filter (AM-W)
CF2002	CFM-455J1	"	" (SSB, CW, FSK, AM-N)
CF2003	CFW-455E	"	" (FM)
CF2004	LFB-15	"	" (")

CD2001	SFD-455S4	Ceramic Filter	RX FM Discriminator
--------	-----------	----------------	---------------------

AF UNIT

Part No.	Device	Type	Function
Q3001	2SC732GR	Transistor	TX MIC Amplifier
Q3002	2SC945AP	"	" (FM)
Q3003	"	"	" (")
Q3004	"	"	" (")
Q3005	"	"	TX FM Carrier VCXO
Q3006	"	"	TX FM IF Amplifier
Q3007	"	"	TX MIC Amplifier (SSB, AM)
Q3008	"	"	" (SSB, AM, FSK)
Q3009	MC1496P	IC	TX Balanced Modulator (SSB, CW, AM, FSK)
Q3010	2SK107-3	JFET	TX AM ALC Amplifier
Q3011	2SC945AP	Transistor	TX VOX Amplifier
Q3012	"	"	"
Q3013	2SC1815GR	"	TX VOX Compensator
Q3014	"	"	"
Q3015	2SC945AP	"	TX AMGC Amplifier
Q3016	"	"	TX ANTI-TRIP Amplifier
Q3017	2SC1815GR	"	"
Q3018	2SA564AR	"	TX ANTI-TRIP Switch
Q3019	MC14011B	IC	TX VOX Gate
Q3020	2SC1815GR	Transistor	TX VOX Switch
Q3021	3SK73GR	MOS FET	RX Carrier Premixer
Q3022	2SC1815Y	Transistor	RX Carrier Buffer Amplifier
Q3023	MC14066B	IC	AF Mode Switch
Q3024	2SC945AP	Transistor	RX AF Preamplifier
Q3025	"	"	RX AF Active LPF
Q3026	AN6551	IC	RX AF APF, CW Sidetone Filter
Q3027	2SC945AP	Transistor	RX AF Buffer Amplifier (for AF OUT)
Q3028	μ PC2002V	IC	RX Audio Amplifier
Q3029	μ PC78L05	"	Regulator (FSK Circuit)
Q3030	Not Used		
Q3031	2SA733AP	Transistor	MODE Switch (SSB)
Q3032	2SA950Y	"	" (CW)
Q3033	2SA733AP	"	" (AM)
Q3034	"	"	" (FSK)
Q3035	2SA950Y	"	" (FM)
Q3036	2SB774	"	" (TX FM)
Q3037	NJM78L09A	IC	Regulator (TX FM Carrier VCXO)
Q3038	ND487R1-3R	IC (Ring Module)	RX Balanced Demodulator
D3001	1SS53	Si Diode	TX MIC Amplifier (Q3001) Disable Switch (FSK)
D3002	1S188FM	Ge Diode	TX FM IDC
D3003	"	"	"
D3004	FC53M-5	Varactor Diode	TX FM Modulator
D3005	MV103	Varistor Diode	Temperature Compensator [TX FM Modulator (D3005) Bias]
D3006	1SS53	Si Diode	TX FM Limiter
D3007	"	"	"

D3008	1SS53	Si Diode	MODE Switch (AM, CW TX IF OUT)
D3009	"	"	" (TX FM IF)
D3010	"	"	T/R Switch (TX CW, AM, FM IF OUT)
D3011	"	"	" (" " ")
D3012	"	"	TX MIC Amplifier (Q3007) Disable Switch (CW, FM)
D3013	"	"	TX MIC Amplifier (Q3008) Disable Switch (CW, FM)
D3014	"	"	MODE Switch (SSB, FSK TX IF OUT)
D3015	"	"	" (TX Bal Mod out for CW, AM)
D3016	"	"	Diode OR (TX Bal Mod out CW)
D3017	"	"	" (" " " " AM)
D3018	"	"	TX Balanced Modulator (Q3009) Carrier Balance Control Switch (AM)
D3019	"	"	TX Balanced Modulator (Q3009) Carrier Balance Control Switch (CW)
D3020	"	"	Diode OR (MIC Amplifier Disable on CW)
D3021	"	"	" (" " " " FM)
D3022	"	"	TX AM ALC Impedance Isolator
D3023	"	"	TX VOX Amplifier (Q3011) Disable Switch (CW)
D3024	"	"	TX ANTI-TRIP Amplifier (Q3016) Disable Switch (CW)
D3025	1N270	Ge Diode	TX ANTI-TRIP Clamp
D3026	1SS53	Si Diode	TX ANTI-TRIP Control Switch (FSK) (FM)
D3027	"	"	"
D3028	HZ5C1	Zener Diode	Regulator [for TX FM Modulator (D3004) Bias]
D3029	1N270	Ge Diode	TX VOX Clamp
D3030	1SS53	Si Diode	RX Carrier Premixer (Q3021) Disable Switch (AM)
D3031	HZ5C1	Zener Diode	TX VOX AMP Clipper
D3032	1SS53	Si Diode	RX Carrier Premixer (Q3021) Disable Switch (FM)
D3033	Not Used		
D3034	"		
D3035	1SS53	Si Diode	TX BFO Switch (Input to Q3009)
D3036	"	"	Diode OR (CW, FSK +9V Line, from CW 9V)
D3037	"	"	" (" " " " , from TX FSK 9V)
D3038	Not Used		
D3039	1SS53	Si Diode	Diode OR (TX FSK IF OUT)
D3040	"	"	" (TX SSB IF OUT)
D3041	"	"	" (FSK for SSB, CW, FSK 9V MODE Line)
D3042	"	"	" (CW " " " ")
D3043	"	"	" (SSB " " " ")
D3044	RD7.5EB1	Zener Diode	Regulator (FM TX 9V)
D3045	1SS53	Si Diode	Diode OR (FSK for FM 9V)
D3046	"	"	" (AM " ")
X3001	8.9875MHz	Crystal (HC-18/T3P)	TX FM Carrier VCXO

PLL UNIT

Part No.	Device	Type	Function
Q4001	MPS-A13	Transistor	PLL BFO Active LPF
Q4002	2SK19TM-GR	Junction FET	PLL BFO VCO
Q4003	2SC535A	Transistor	PLL BFO Buffer Amplifier
Q4004	NJM78L09A	IC	Regulator (PLL +9V Line)
Q4005	2SC535A	Transistor	PLL BFO Buffer Amplifier
Q4006	HD10551	IC	PLL BFO 1/10 Divider
Q4007	2SC535A	Transistor	BLL BFO Buffer Amplifier
Q4008	2SC1815GR	"	PLL Data Switch (for PLL BFO, P. DIV, ϕ DET)
Q4009	3SK73GR	MOS FET	PLL BFO Buffer Amplifier
Q4010	μ PC7805H	IC	Regulator (PLL +5V Line)
Q4011	MB8718	"	PLL BFO, P. DIV, ϕ DET

Q4012	2SC380TM-Y	Transistor	PLL BFO IF Amplifier
Q4013	SN76514N	IC	PLL BFO Mixer
Q4014	MB8718	"	PLL (RX 1st, TX 2nd Local) P. DIV, ϕ DET
Q4015	MC14518B	"	PLL Reference 1/2, 1/10, 1/100 Divider
Q4016	MC14027B	"	RX Marker Switch, 1/2 Divider
Q4017	2SC380TM-Y	Transistor	RX Marker Buffer Amplifier
Q4018	SN74LS90N	IC	PLL Reference 1/10 Divider
Q4019	"	"	PLL Reference 1/3 Divider
Q4020	"	"	PLL Reference 1/10 Divider
Q4021	2SC380TM-Y	Transistor	PLL (RX 1st, TX 2nd Local) IF Buffer Amplifier
Q4022	HD10551	IC	PLL (RX 1st, TX 2nd Local) 1/10 Divider
Q4023	2SC380TM-Y	Transistor	PLL Reference 50 kHz Buffer Amplifier
Q4024	2SC1923R	"	PLL (RX 1st, TX 2nd Local) IF Amplifier
Q4025	2SC535C	"	PLL Reference 30 MHz Amplifier
Q4026	2SC380TM-Y	"	RX 2nd, TX 1st Local Oscillator
Q4027	"	"	RX 2nd, TX 1st Local Buffer Amplifier
Q4028	SN76514N	IC	PLL (RX 2nd, TX 1st Local) Mixer
Q4029	2SC1923R	Transistor	PLL (RX 2nd, TX 1st Local) IF Amplifier
Q4030	SN76514N	IC	PLL (RX 1st, TX 2nd Local) Mixer
Q4031	2SC1815GR	Transistor	PLL Unlock Switch
D4001	1SV55	Varactor Diode	PLL BFO VCO
D4002	1N60	Ge Diode	Clamp
D4003	1SS53	Si Diode	TX BFO Switch
X4001	38.0675MHz	Crystal (HC-18/U)	RX 2nd, TX 1st Local Oscillator
TH4001	31D26	Thermistor	Temperature Compensator (PLL BFO VCO)

VCO UNIT

Part No.	Device	Type	Function
Q5001	NJM78L09A	IC	Regulator (for VCO Circuit)
Q5002	2SA733AP	Transistor	RX 1st, TX 2nd Local VCO (Q5003) Switch
Q5003	2SK19TM-BL	JFET	RX 1st, TX 2nd Local VCO (47.055–49.055 MHz)
Q5004	"	"	" (49.055–52.055 MHz)
Q5005	2SA733AP	Transistor	RX 1st, TX 2nd Local VCO (Q5004) Switch
Q5006	"	"	RX 1st, TX 2nd Local VCO (Q5007) Switch
Q5007	2SK19TM-BL	JFET	RX 1st, TX 2nd Local VCO (52.055–55.055 MHz)
Q5008	"	"	" (55.055–58.055 MHz)
Q5009	2SA733AP	Transistor	RX 1st, TX 2nd Local VCO (Q5008) Switch
Q5010	"	"	RX 1st, TX 2nd Local VCO (Q5011) Switch
Q5011	2SK19TM-BL	JFET	RX 1st, TX 2nd Local VCO (58.055–61.055 MHz)
Q5012	"	"	" (61.055–64.055 MHz)
Q5013	2SA733AP	Transistor	RX 1st, TX 2nd Local VCO (Q5012) Switch
Q5014	"	"	RX 1st, TX 2nd Local VCO (Q5015) Switch
Q5015	2SK19TM-BL	JFET	RX 1st, TX 2nd Local VCO (64.055–67.055 MHz)
Q5016	"	"	" (67.055–70.055 MHz)
Q5017	2SA733AP	Transistor	RX 1st, TX 2nd Local VCO (Q5016) Switch
Q5018	"	"	RX 1st, TX 2nd Local VCO (Q5019) Switch
Q5019	2SK19TM-BL	JFET	RX 1st, TX 2nd Local VCO (70.055–73.055 MHz)
Q5020	"	"	" (73.055–77.055 MHz)
Q5021	2SA733AP	Transistor	RX 1st, TX 2nd Local VCO (Q5020) Switch
Q5022	3SK73GR	MOS FET	RX 1st, TX 2nd Local Buffer Amplifier
Q5023	"	"	"
Q5024	2SC1815GR	Transistor	RX 1st Local Disable Switch (GEN 26–30 MHz)
Q5025	SN74LS145N	IC	Decoder (for RX 1st, TX 2nd Local VCO Selector)

D5001	1SV55	Varactor Diode	RX 1st, TX 2nd Local VCO	(47.055–49.055 MHz)
D5002	1SS53	Si Diode	RX 1st, TX 2nd Local VCO	(Q5003) Switch
D5003	"	"	RX 1st, TX 2nd Local VCO	(Q5004) Switch
D5004	1SV55	Varactor Diode	RX 1st, TX 2nd Local VCO	(49.055–52.055 MHz)
D5005	"	"	"	(52.055–55.055 MHz)
D5006	1SS53	Si Diode	RX 1st, TX 2nd Local VCO	(Q5007) Switch
D5007	"	"	RX 1st, TX 2nd Local VCO	(Q5008) Switch
D5008	1SV55	Varactor Diode	RX 1st, TX 2nd Local VCO	(55.055–58.055 MHz)
D5009	"	"	"	(58.055–61.055 MHz)
D5010	1SS53	Si Diode	RX 1st, TX 2nd Local VCO	(Q5011) Switch
D5011	"	"	RX 1st, TX 2nd Local VCO	(Q5012) Switch
D5012	1SV55	Varactor Diode	RX 1st, TX 2nd Local VCO	(61.055–64.055 MHz)
D5013	"	"	"	(64.055–67.055 MHz)
D5014	1SS53	Si Diode	RX 1st, TX 2nd Local VCO	(Q5015) Switch
D5015	"	"	RX 1st, TX 2nd Local VCO	(Q5016) Switch
D5016	1SV55	Varactor Diode	RX 1st, TX 2nd Local VCO	(67.055–70.055 MHz)
D5017	"	"	"	(70.055–73.055 MHz)
D5018	1SS53	Si Diode	RX 1st, TX 2nd Local VCO	(Q5019) Switch
D5019	"	"	RX 1st, TX 2nd Local VCO	(Q5020) Switch
D5020	1SV55	Varactor Diode	RX 1st, TX 2nd Local VCO	(73.055–77.055 MHz)
TH5001	D22A	Thermistor	Temperature Compensator (RX 1st, TX 2nd Local VCO)	

CPU UNIT

Part No.	Device	Type	Function
Q6001	2SC1815Y	Transistor	Buffer
Q6002	2SA733AP	"	RESET Switch
Q6003	MC14093B	IC	NAND Gate (CPU RESET Timing)
Q6004	SN74LS14	"	Inverter
Q6005	MSM80C85ARS	"	CPU
Q6006	SN74LS75	"	Latch (PLL Output Data)
Q6007	SN74LS190	"	Up/Down Counter (Frequency Control)
Q6008	SN74LS02	"	NOR Gate
Q6009	MC14016	"	Analog Switch (Frequency Control Data Input)
Q6010	SN74LS74	"	Flip-flop (CK INH, ST OUT)
Q6011	SN74LS373	"	Latch (Address Data)
Q6012	SN74LS42	"	Decoder (")
Q6013	SN74LS02	"	NOR Gate
Q6014	"	"	"
Q6015	"	"	"
Q6016	μ PD2364C-0402	"	ROM
Q6017	μ PD445LC-1	"	RAM
Q6018	Not Used		
Q6019	SN74LS365	IC	Bus Driver (TRS Input Data)
Q6020	"	"	" (")
Q6021	SN74LS373	"	Latch (TRS Data, FSK Shift Data)
Q6022	"	"	" (WIDTH Freq Data)
Q6023	"	"	" (")
Q6024	μ PD8279C-5	"	Programmable Keypad, Display Controller (Key Input Data, Frequency Display DATA)
Q6025	SN74LS145	"	Decoder (Key Scan Line)
Q6026	μ PD8255AC5	"	Programmable I/O Port (IF SHIFT/BAND/MODE Data)
Q6027	"	"	" (PLL Data, VCO Select Data)
Q6028	MC14504	"	Level Shifter (PLL Output Data)
Q6029	"	"	" (")

Q6030	2SA733AP	Transistor	Regulator (CPU Unit +5V Line)
Q6031	Not Used		
Q6032	μ PC78L05	IC	Regulator (CPU Unit +5V Line)
Q6033	SN74LS123	"	Multivibrator (Buzzer Switching)
Q6034	TBP18SA030N	"	ROM (AUX Band Data)
D6001	10D1	Si Diode	Switch (System Backup)
D6002	1S1555	"	" (")
D6003	WZ071	Zener Diode	RESET Switch
D6004	1SS106	Schottky Barrier Di.	PD Data Output Disable Diode OR
D6005	"	"	" " " " "
D6006	1S1555	Si Diode	\overline{CS} Diode OR
D6007	"	"	" " "
D6008	"	"	$\overline{CE1}$ Diode OR
D6009	"	"	" " "
D6010	"	"	PD Data Output Disable Switch
D6011	"	"	Status Data Output Enable
D6012	"	"	RESET Switch
X6001	6 MHz	Crystal (HC-18/U)	CPU Clock

MEMORY CHECK DECODER UNIT

Part No.	Device	Type	Function
Q2801	SN74LS05	IC	Inverter
Q2802	"	"	"
Q2803	SN74LS74	"	Latch (M. CHECK Data)
Q2804	2SC1815Y	Transistor	M. CHECK Data Reset Switch
Q2805	μ PD445LC-1	IC	RAM
D2801	1SS97	Schottky Barrier Di.	A2 M CK Gate
D2802	"	"	A5 M CK Gate
D2803	"	"	A6 M CK Gate

VFO UNIT

Part No.	Device	Type	Function
Q7001	TC5081P	IC	PLL VCO-1 Phase Detector
Q7002	MPS-A13	Transistor	PLL VCO-1 Active LPF
Q7003	2SC535A	"	PLL VCO-1
Q7004	"	"	PLL VCO-1 Buffer Amplifier
Q7005	SN76514N	IC	PLL VCO-1 Mixer
Q7006	2SC535A	Transistor	PLL VCO-1 IF Amplifier
Q7007	TC9122A	IC	PLL VCO-1 Programmable Divider
Q7008	2SC535A	Transistor	PLL VCO-1 Buffer Amplifier
Q7009	HD10551P	IC	PLL VCO-1 1/10 Divider
Q7010	SN76514N	"	PLL Mixer
Q7011	2SC1815Y	Transistor	PLL IF Amplifier
Q7012	"	"	"
Q7013	SN74LS90	IC	PLL IF 1/10 Divider
Q7014	SN76514N	"	PLL Mixer
Q7015	2SC535A	Transistor	PLL IF Buffer Amplifier
Q7016	2SK19TM-GR	JFET	PLL VCO-2 Buffer Amplifier
Q7017	SN76514N	IC	PLL VCO-2 Mixer
Q7018	2SC535A	Transistor	PLL VCO-2 IF Amplifier
Q7019	TC9122A	IC	PLL VCO-2 Programmable Divider

Q7020	TC5081P	IC	PLL VCO-2 Phase Detector
Q7021	2SC1815Y	Transistor	PLL LOCK Lamp Switch
Q7022	MPS-A13	"	PLL VCO-2 Active LPF
Q7023	2SK19TM-GR	JFET	PLL VCO-2
Q7024	2SC535A	Transistor	PLL VCO-2 Buffer Amplifier
Q7025	HD10551	IC	PLL VCO-2 1/10 Divider
Q7026	2SD880Y	Transistor	Regulator (PLL Circuit)
Q7027	μPC7808	IC	" (PLL +8V Line)
Q7028	μPC7805	"	" (PLL +5V Line)
Q7029	2SC1815Y	Transistor	PLL Reference Oscillator
Q7030	"	"	PLL Reference Buffer Amplifier
Q7031	2SC535A	"	PLL Reference Tripler
Q7032	"	"	PLL Reference Buffer Amplifier
Q7033	"	"	PLL Reference Doubler
Q7034	2SC1815Y	"	PLL Reference Buffer Amplifier
Q7035	2SC535A	"	PLL VCO-2 IF Buffer Amplifier
Q7036	2SA733AP	"	PLL Reference 10 kHz Buffer Amplifier
D7001	1S2209	Varactor Diode	PLL VCO-1
D7002	1SV55	"	PLL VCO-2
D7003	WZ100	Zener Diode	Regulator (PLL Circuit)
X7001	30MHz	Crystal (HC-18/U)	PLL Reference Oscillator
TH7001	31D26	Thermistor	Temperature Compensator (PLL VCO-2)
TH7002	PTH507A01- BG330N020	Posistor	" (PLL Reference Oscillator)

LPF UNIT

Part No.	Device	Type	Function
D9001	1SS97	Schottky Barrier Di.	TX AM ALC Detector
D9002	"	"	"
D9003	"	"	TX FWD Detector
D9004	"	"	TX REF Detector
D9005	"	"	TX ALC Detector
D9006	"	"	TX REV ALC Detector
D9007	"	"	TX ALC Detector
D9008	"	"	TX REV ALC Detector
D9009	1S1555	Si Diode	Back Pulse Canceller [for 12m, 10m LPF Relay (RL9013, 9014)]
D9010	"	"	Back Pulse Canceller [for 17m, 15m LPF Relay (RL9011, 9012)]
D9011	"	"	" [for 20m LPF Relay (RL9009, 9010)]
D9012	"	"	" [for 30m LPF Relay (RL9007, 9008)]
D9013	"	"	" [for 40m LPF Relay (RL9005, 9006)]
D9014	"	"	" [for 80m LPF Relay (RL9003, 9004)]
D9015	"	"	" [for 160m LPF Relay (RL9001, 9002)]
D9016	"	"	" [for ANT Relay (RL9015)]

DIAL UNIT

Part No.	Device	Type	Function
Q1301	MC14093B	IC	NAND Schmitt Trigger

Q1302	MC14012B	IC	Dual 4-Input NAND Gate
Q1303	MC14001B	"	NOR Gate
Q1304	MC14584B	"	Schmitt Trigger
Q1305	MC14011B	"	NAND Gate Multivibrator
Q1306	MC14013B	"	"D" Type Flip-Flop
Q1307	SN74LS00	"	NAND Gate
Q1308	MC14016B	"	Analog Switch
D1301	1S1555	Si Diode	Diode OR
D1302	"	"	"
D1303	"	"	"
D1304	"	"	"
D1305	"	"	Trigger
D1306	"	"	"
D1307	"	"	Diode OR
D1308	"	"	"
D1309	"	"	"
D1310	"	"	"

DISPLAY UNIT (A)

Part No.	Device	Type	Function
V1401	FIP-9E8A	FCD	Frequency Display
V1402	FIP-9P5	"	Sub Dial Display
D1401	TLY205	LED	ATT Indicator
D1402	"	"	M. CHECK Indicator
D1403	"	"	EXT Indicator
D1404	"	"	SPLIT Indicator
D1405	"	"	MR Indicator
D1406	"	"	VFO Indicator

DISPLAY UNIT (B)

Part No.	Device	Type	Function
Q1601	TC5067BP	IC	FCD Driver (for MODE Display)
Q1602	MSL912RS	"	" (for Segment)
Q1603	"	"	" (for Digit)
Q1604	"	"	" (")
Q1605	SN7445	"	Decoder (MODE Display Data)
Q1606	MC14514B	"	" (Display Data)
Q1607	NJM78L05A	"	Regulator (for Display Unit)
Q1608	2SC2002L	Transistor	DC-DC Converter OSC
Q1609	2SC1815GR	"	Blanking sw (for MODE Display)
D1601	1S1554	Si Diode	Diode Matrix (for MODE Display)
D1602	"	"	" (")
D1603	"	"	" (")
D1604	"	"	" (")
D1605	Not Used		
	{	{	{
D1612	Not Used		
D1613	1S1554	Si Diode	Diode Matrix (for MODE Display)
	{	{	{
D1624	1S1554	Si Diode	Diode Matrix (for MODE Display)

D1625	Not Used		
D1632	Not Used		
D1633	1S1554	Si Diode	Rectifier (DC-DC Converter Vout)
D1634	1N270	Ge Diode	Timing (for MODE Display)

DISPLAY UNIT (C)

Part No.	Device	Type	Function
Q2701	SN74LS75P	IC	Latch (MODE Data)
Q2702	SN74LS145N	"	Decoder (")
Q2703	2SA733AP	Transistor	Driver (for M. CHECK LED)
D2701	1S1554	Si Diode	Diode Matrix (for MODE Data)
D2716	1S1554	Si Diode	Diode Matrix (for MODE Data)

KEY MATRIX UNIT

Part No.	Device	Type	Function
D1701	TLY205	LED	M. SHIFT Indicator
D1702	"	"	CLAR RX Indicator
D1703	"	"	CLAR TX Indicator
D1704	"	"	TAB Indicator
D1705	"	"	HAM Indicator
D1706	"	"	GEN Indicator
D1707	1SS53	Si Diode	Switch (for Keypad Switch)
D1727	1SS53	Si Diode	Switch (for Keypad Switch)

FSK UNIT

Part No.	Device	Type	Function
Q1801	SN74LS00	IC	Oscillator (CW Sidetone Pitch, FSK Shift Frequency)
Q1802	TC9122P	"	Programmable Divider (for CW Sidetone Pitch, FSK Shift Frequency)
Q1803	MC14027B	"	1/4 Divider (for CW Sidetone Pitch, FSK Shift Frequency)
Q1804	SN74LS04	"	Inverter (for FSK Shift Frequency Selector)
Q1805	SN74LS09	"	AND Gate (")
Q1806	μPC78L05	"	Regulator (for CW, FSK +5V Line)
Q1807	2SC1815GR	Transistor	Oscillator (Q1801) Controller
Q1808	"	"	KEY Switch
Q1809	"	"	"
Q1810	"	"	FSK Buffer Amplifier
Q1811	"	"	FSK Shift Frequency External Control Switch
Q1812	"	"	CW Break-in Switch
Q1813	"	"	CW Break-in Delay Controller
Q1814	"	"	CW Sidetone Buffer Amplifier

D1801	WZ034	Zener Diode	KEY Switch
D1802	1N270	Ge Diode	"
D1803	1SS53	Si Diode	Diode Matrix (for CW Sidetone Pitch, FSK Shift Frequency Selector)
}	}	}	}
D1825	1SS53	Si Diode	Diode Matrix (for CW Sidetone Pitch, FSK Shift Frequency Selector)
D1826	1N270	Ge Diode	Diode OR (for FSK Shift Frequency Controller)
}	}	}	}
D1832	1N270	Ge Diode	Diode OR (for FSK Shift Frequency Controller)
D1833	HZ5C2	Zener Diode	Regulator (CW +5V Line)
D1834	1SS53	Si Diode	CW Break-in Switch
D1835	1N270	Ge Diode	KEY Switch
X1801	6.8MHz	Crystal (HC-18/U)	Oscillator (for CW Sidetone Pitch, FSK Shift Frequency)

REG UNIT

Part No.	Device	Type	Function
Q1901	MC14572	IC	Relay Timing Controller
Q1902	2SC1815GR	Transistor	T/R Switch (RX ON)
Q1903	2SA950Y	"	ANT Relay (RL9015) Driver
Q1904	2SA733AQ	"	CPU TX 9V Switch (TX ON)
Q1905	"	"	Relay Driver (for RL1902; TX ON)
Q1906	2SC945AQ	"	Regulator (+9V Line)
Q1907	"	"	" (")
Q1908	"	"	" (")
Q1909	2SC2002L	"	Oscillator (DC-DC Converter)
Q1910	2SC1815Y	"	Start up Current Limiter (+9V Bus)
Q1911	"	"	TX VOX Switch
Q1912	"	"	"
Q1913	2SA733AQ	"	Relay Driver (for RL1901)
Q1914	2SA950Y	"	RX 9V Switch (RX ON)
Q1915	"	"	RX 13.5V Switch (RX ON)
Q1916	2SC1815GR	"	T/R Switch (TX ON)
Q1917	2SA496Y	"	TX 9V Switch (TX ON)
Q1918	"	"	TX 13.5V Switch (TX ON)
Q1919	2SA733AQ	"	ANT Relay Driver (Q1903) Controller
Q1920	"	"	TX Monitor Switch Controller
D1901	1SS53	Si Diode	Diode OR (for TX Controller)
D1902	"	"	Back Pulse Cancellor (for RL1901)
D1903	"	"	" (for RL1902)
D1904	"	"	Diode OR (for TX Controller)
D1905	Not Used		
D1906	WZ051	Zener Diode	Regulator (+9V Line)
D1907	1S1588	Si Diode	Rectifier (-9V Line)
D1908	HZ7A2	Zener Diode	Regulator (")
D1909	HZ11C1	"	" (DISP 10V and CPU TX 9V)
D1910	1SS53	Si Diode	Temperature Compensator for D1911
D1911	HZ3C1	Zener Diode	Start up Limiter Regulator
D1912	Not Used		
D1913	"		

D1914	1N270	Ge Diode	Delay Controller
D1915	HZ3C3	Zener Diode	Regulator (-9V Line)
D1916	1N270	Ge Diode	Switch (CW/TX 9V for Monitor)
D1917	WZ033	Zener Diode	TX Monitor Switch (Q1920) Bias Switch (CW)
D1918	1SS53	Si Diode	" " " CW Switch
D1919	1N270	Ge Diode	Monitor RX IF Disable Switch
D1920	"	"	"
D1921	1SS53	Si Diode	Reverse Voltage Protector for Q1901

SWITCH UNIT A

Part No.	Device	Type	Function
Q2301	2SC1815GR	Transistor	CW-CAL Switch
D2301	1SS53	Si Diode	VOX Control Switch (CW-CAL)

PHOTO-INTERRUPTER UNIT

Part No.	Device	Type	Function
RS2601	EE-SH3-X-1	Photo-Interrupter	Frequency Controller
RS2602	"	"	"

PROTECTOR UNIT

Part No.	Device	Type	Function
Q2901	AN6551	IC	Current Limiter
D2901	1S1555	Si Diode	External ALC Switch
D2902	"	"	"
D2903	"	"	ALC Switch

CONTROL UNIT

Part No.	Device	Type	Function
Q3501	AN6551	IC	Sensor Signal DC Amplifier
Q3502	2SC1815Y	Transistor	Fan Motor Driver (Q3503) Controller
Q3503	2SD592Q	"	Fan Motor Driver
Q3504	NJM78L08	IC	Regulator (CONTROL Unit +8V Line)
D3501	1S1555	Si Diode	Switch (for PS Unit Sensor Signal)
D3502	"	"	" (for PA Unit Sensor Signal)
D3503	"	"	Reverse Voltage Protector (for Q3503)

MONITOR UNIT

Part No.	Device	Type	Function
Q3601	2SK107-3	JFET	RX AF Gate (RX ON)
Q3602	2SA733AP	Transistor	CW Gate Controller
Q3603	2SK107-3	JFET	TX Monitor Gate
Q3604	"	"	" Sidetone Gate
Q3605	"	"	AGC Gate
Q3606	2SC509Y	Transistor	Display Dim Controller
D3601	1SS106	Schottky Barrier Di.	RX AF Gate Switch
D3602	1SS53	Si Diode	Switch (CW 9V Line)
D3603	1SS106	Schottky Barrier Di.	AGC Gate Switch

100W PS UNIT

Part No.	Device	Type	Function
Q01	2N5685	Transistor	Regulator (+24V Line)
Q02	2SD717Y	"	" (+13.5V Line)
Q201	2SK147BL	JFET	" (+24V Line)
Q202	2SA1012Y	Transistor	" (")
Q203	2SA950Y	"	" (")
Q301	2SK19TM-GR	JFET	" (+13.5V Line)
Q302	2SA950Y	Transistor	" (")
Q303	2SA1015GR	"	" (")
D01	S25VB10	Si Diode Bridge	Rectifier (+24V Line)
D02	SSVB10	"	" (+13.5V Line)
D201	10D1	Si Diode	" (Sample Voltage)
D202	"	"	" (")
D203	HZ6C1	Zener Diode	Regulator (+24V Line)
D301	10D1	Si Diode	Rectifier (Sample Voltage)
D302	"	"	" (")
D303	HZ6C1	Zener Diode	Regulator (+13.5V Line)
TH01	112302-2	Thermistor	Fan Motor Control Sensor

100W PA UNIT

Part No.	Device	Type	Function
Q8001	2SC1589	Transistor	TX Driver Amplifier
Q8002	2SC2395	"	"
Q8003	"	"	"
Q8004	MRF422	"	TX Final Amplifier
Q8005	"	"	"
Q8006	μPC7808H	IC	Regulator (Final Amplifier Bias)
Q8007	2SD288K	Transistor	" (")

D8001	YZ033	Zener Diode	Regulator (Driver Amplifier Bias)
D8002	10D10	Si Diode	Temperature Compensator (Driver Amplifier Bias)
D8003	"	"	(")
D8004	"	"	(Final Amplifier Bias)
D8005	"	"	(")
TH8001	32D27	Thermistor	Fan Motor Control Sensor

10W PS UNIT

Part No.	Device	Type	Function
Q1501	μ PC78L12	IC	Regulator (+13.5V Line)
Q1502	2SB529D	Transistor	" (")
Q1503	2SD745S	"	" (")
D1501	S5VB10	Si Diode Bridge	Rectifier (+13.5V Line)
D1502	10D1	Si Diode	" (Sample Voltage)
D1503	"	"	" (")
D1504	MV103	Varistor Diode	Temperature Compensator (+13.5V Line)

10W PA UNIT

Part No.	Device	Type	Function
Q2801	2SC2166	Transistor	TX Driver Amplifier
Q2802	2SC2509	"	TX Final Amplifier
Q2803	"	"	"
Q2804	2SD882Q	"	Regulator (Final Amplifier Bias)
Q2805	μ PC78L08	IC	" (")
D2801	YZ033	Zener Diode	Regulator (Driver Amplifier Bias)
D2802	MV11	Varistor Diode	Temperature Compensator (Final Amplifier Bias)

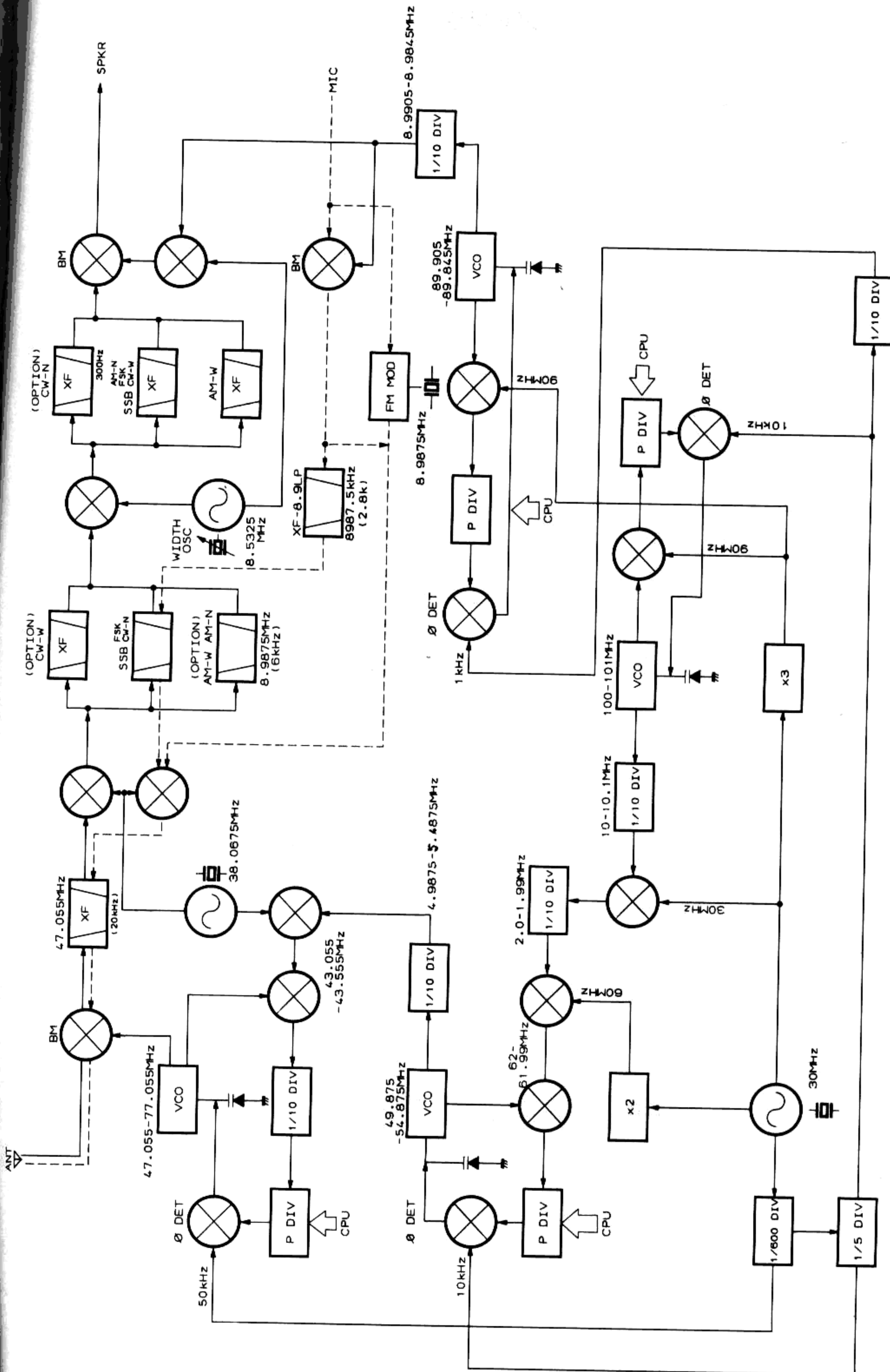

FT-980
FREQUENCY RELATIONSHIPS

B SIGNAL PATHS

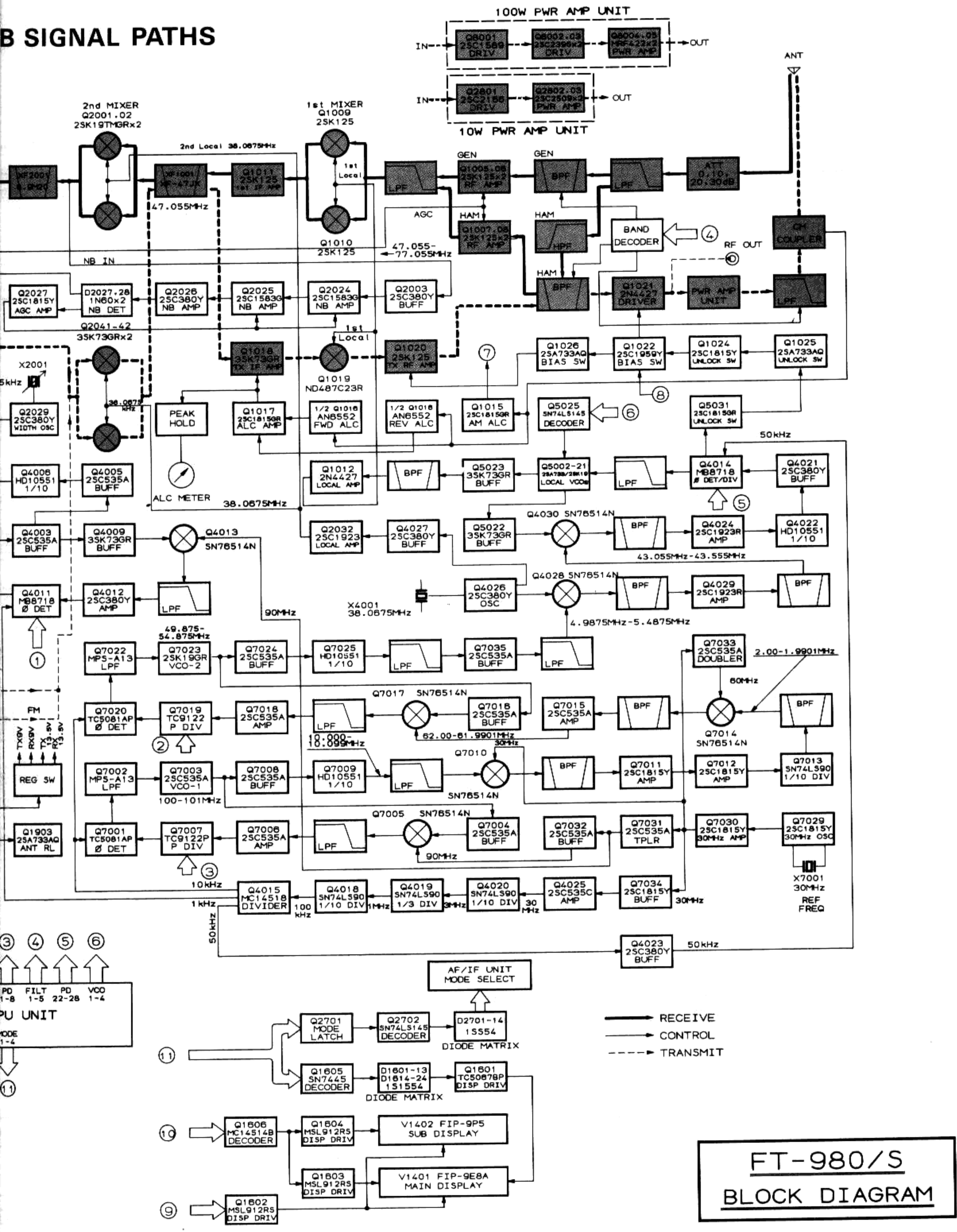

RADIO SIGNAL PATHS

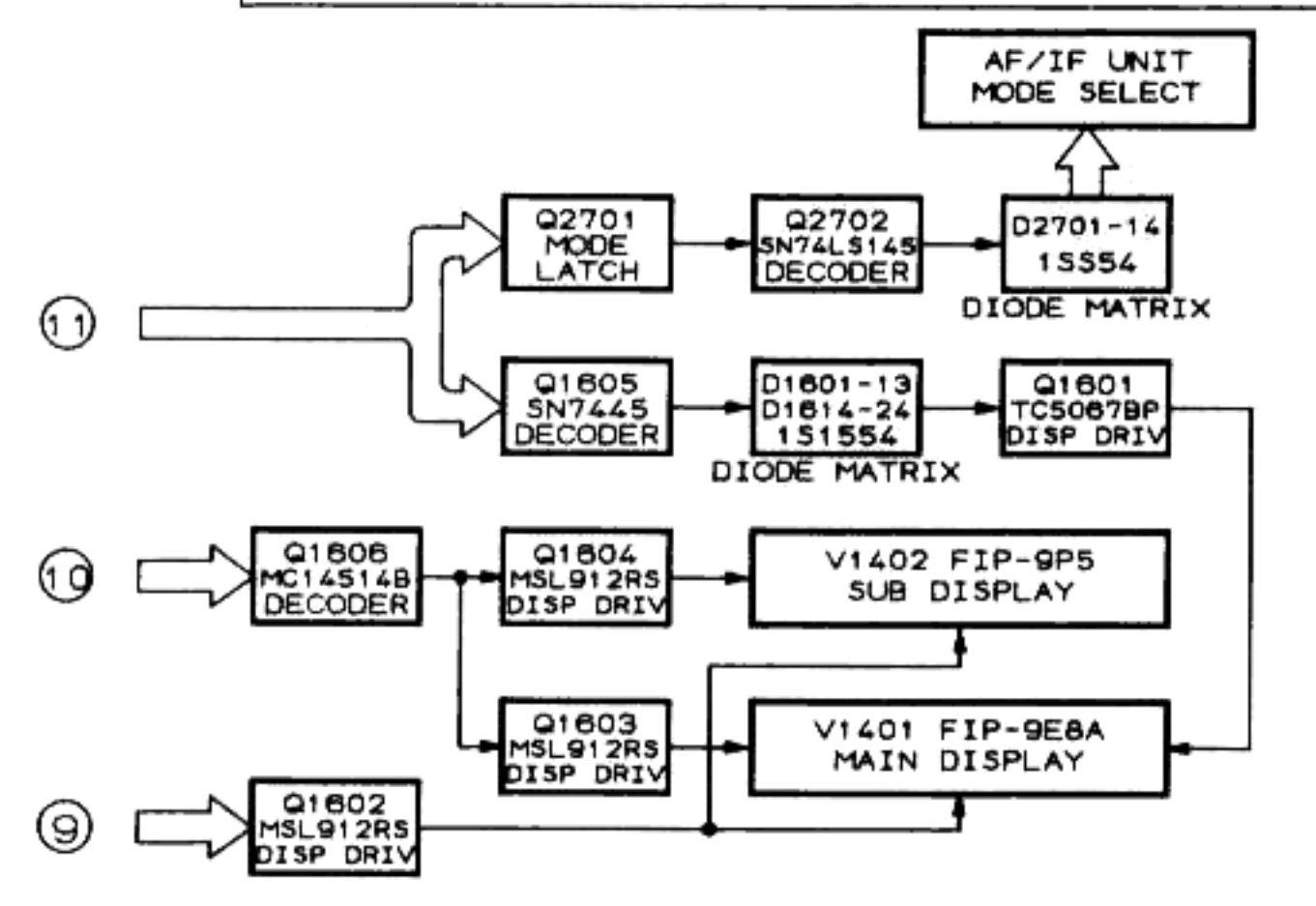
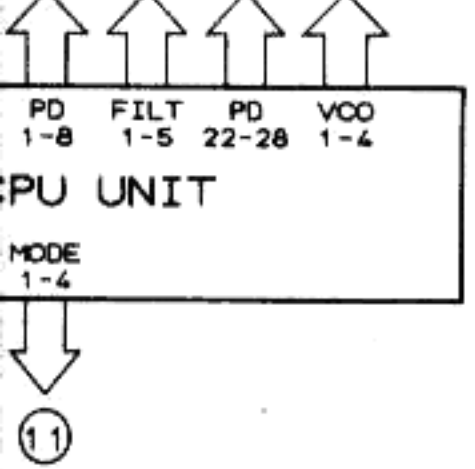
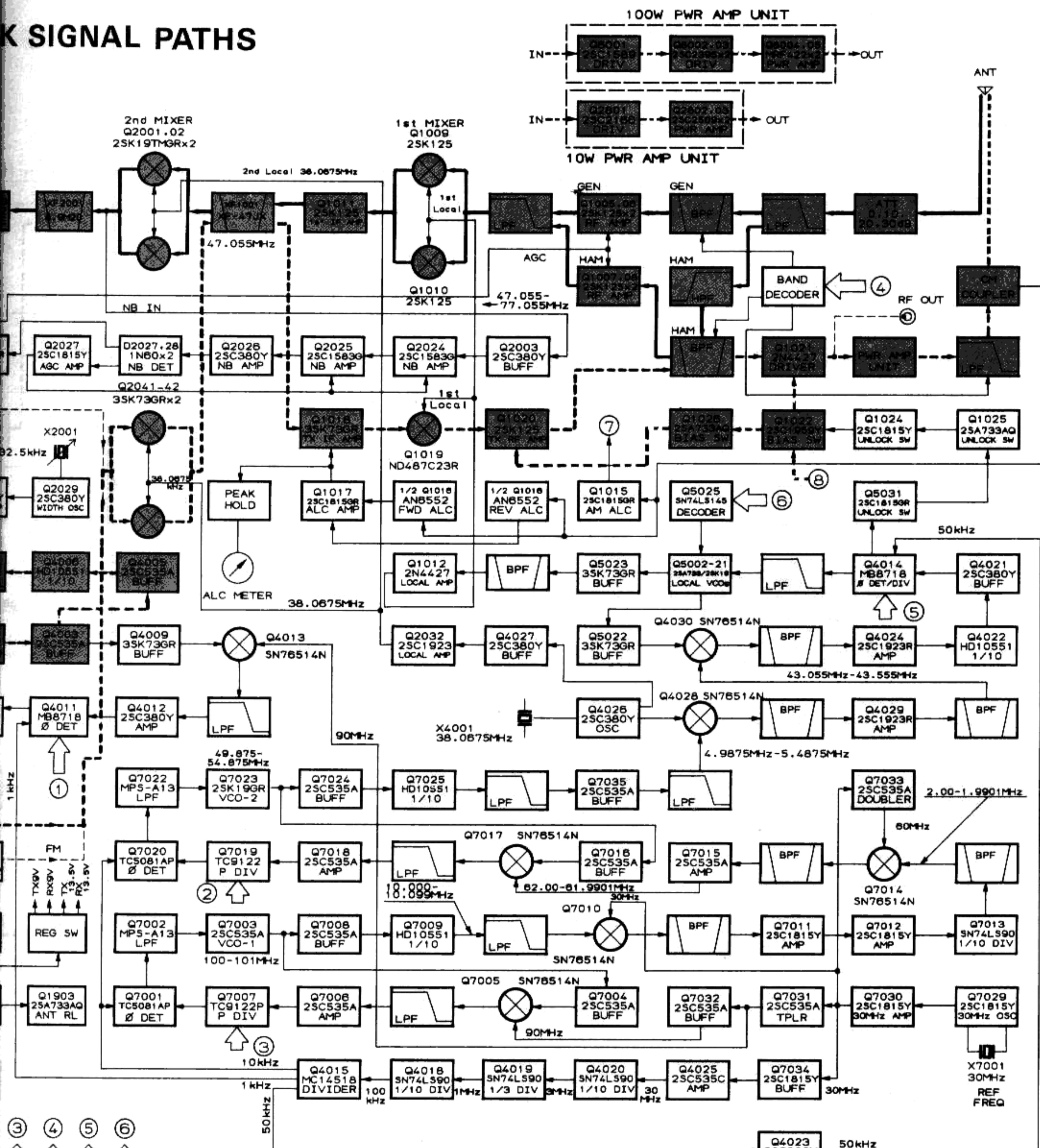

———> RECEIVE
 - - - -> CONTROL
 - - - -> TRANSMIT

**FT-980/S
BLOCK DIAGRAM**

SIGNAL PATHS

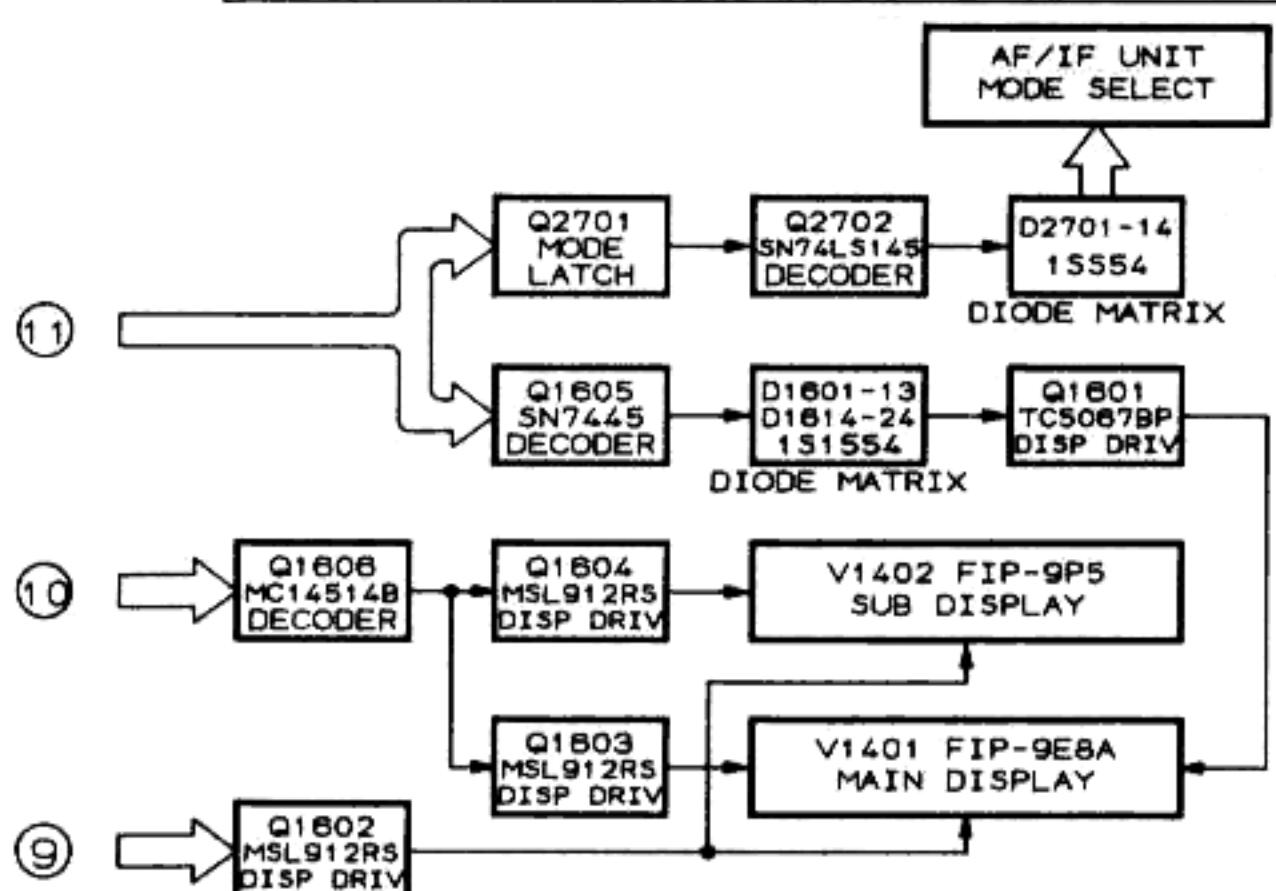
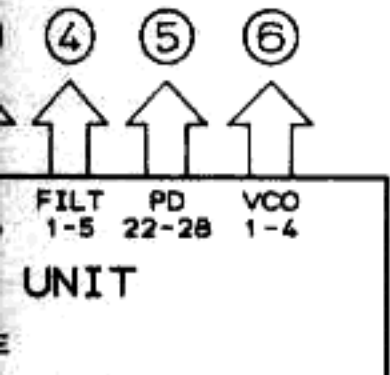
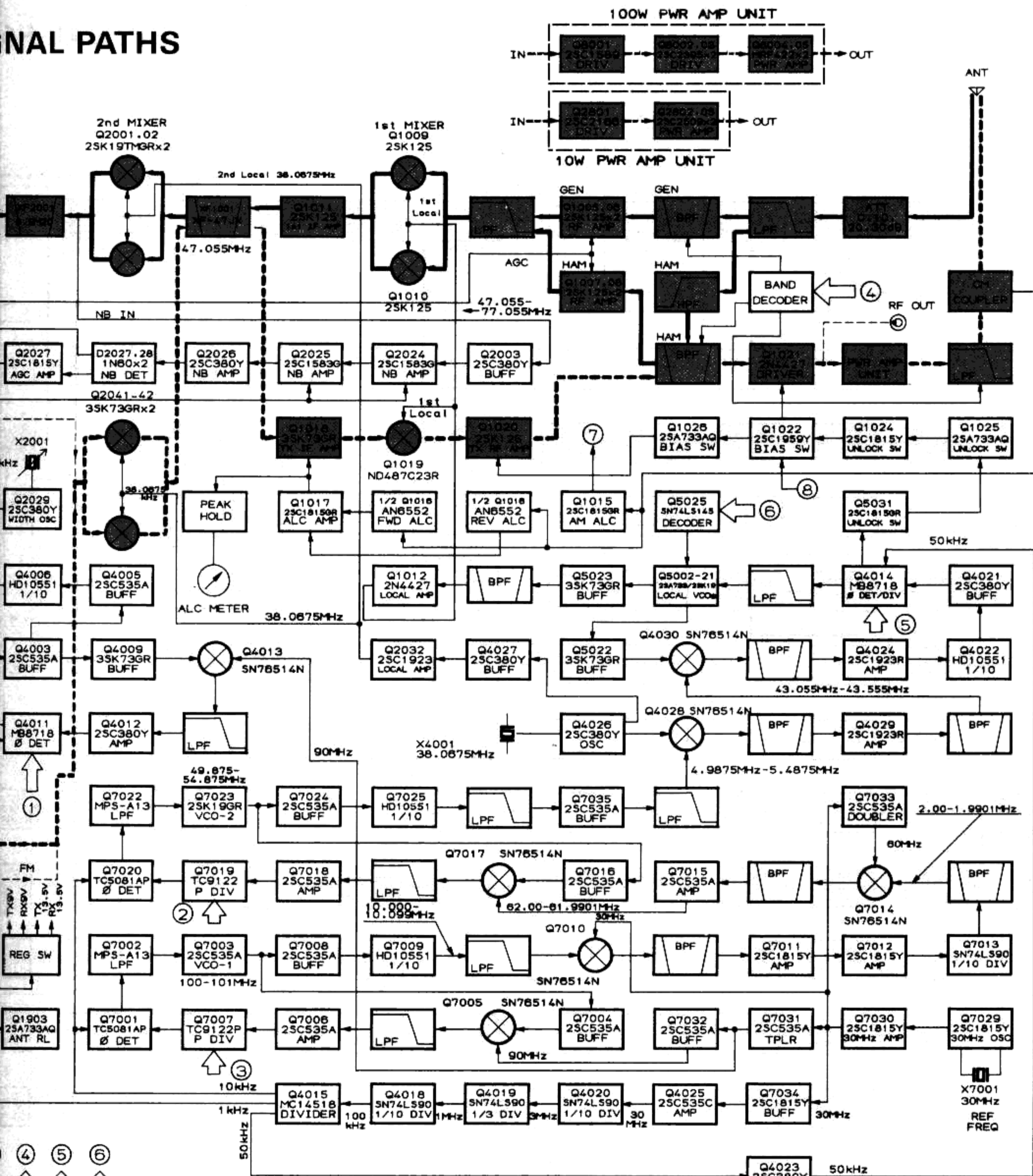

**FT-980/S
BLOCK DIAGRAM**

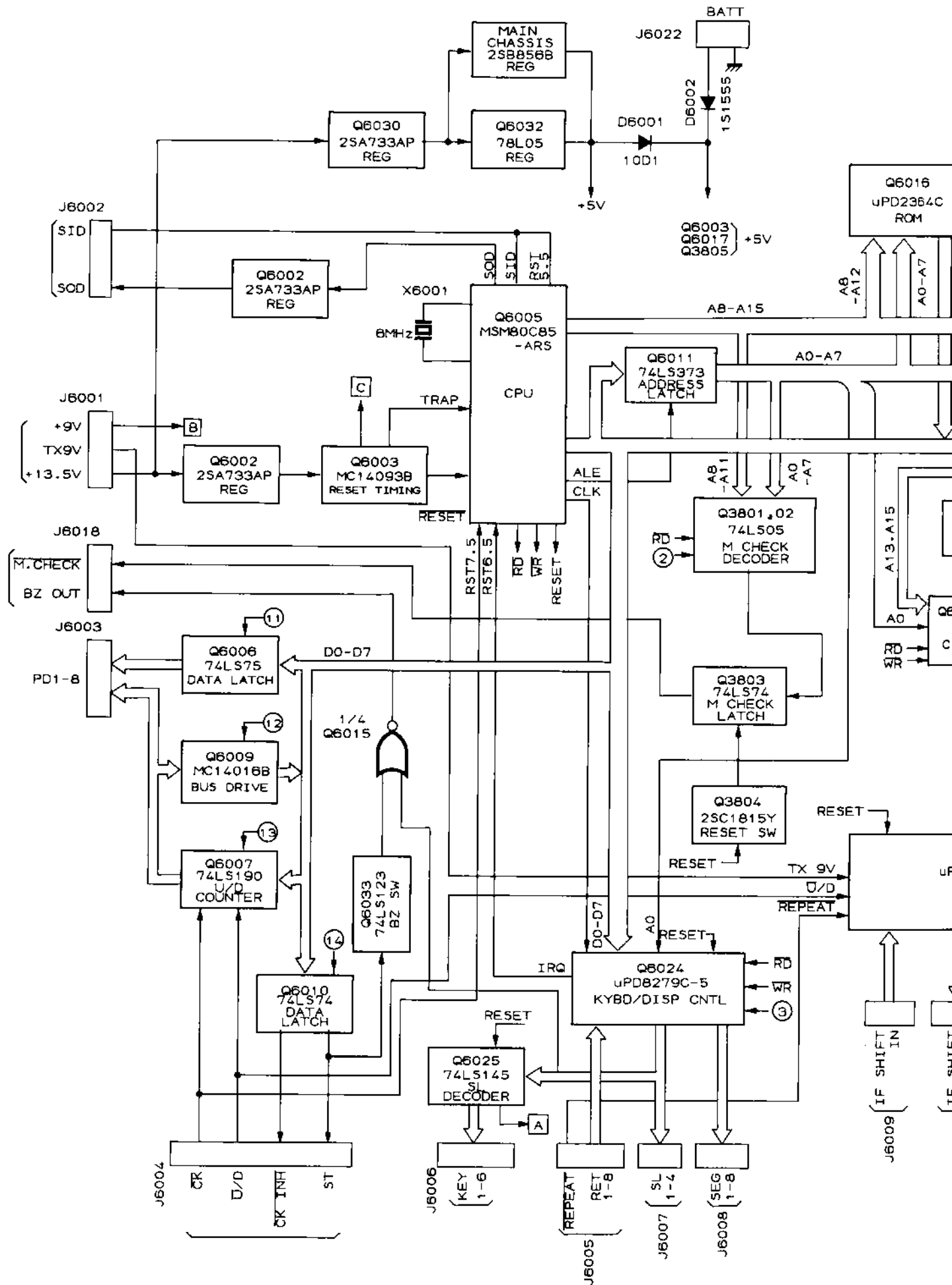

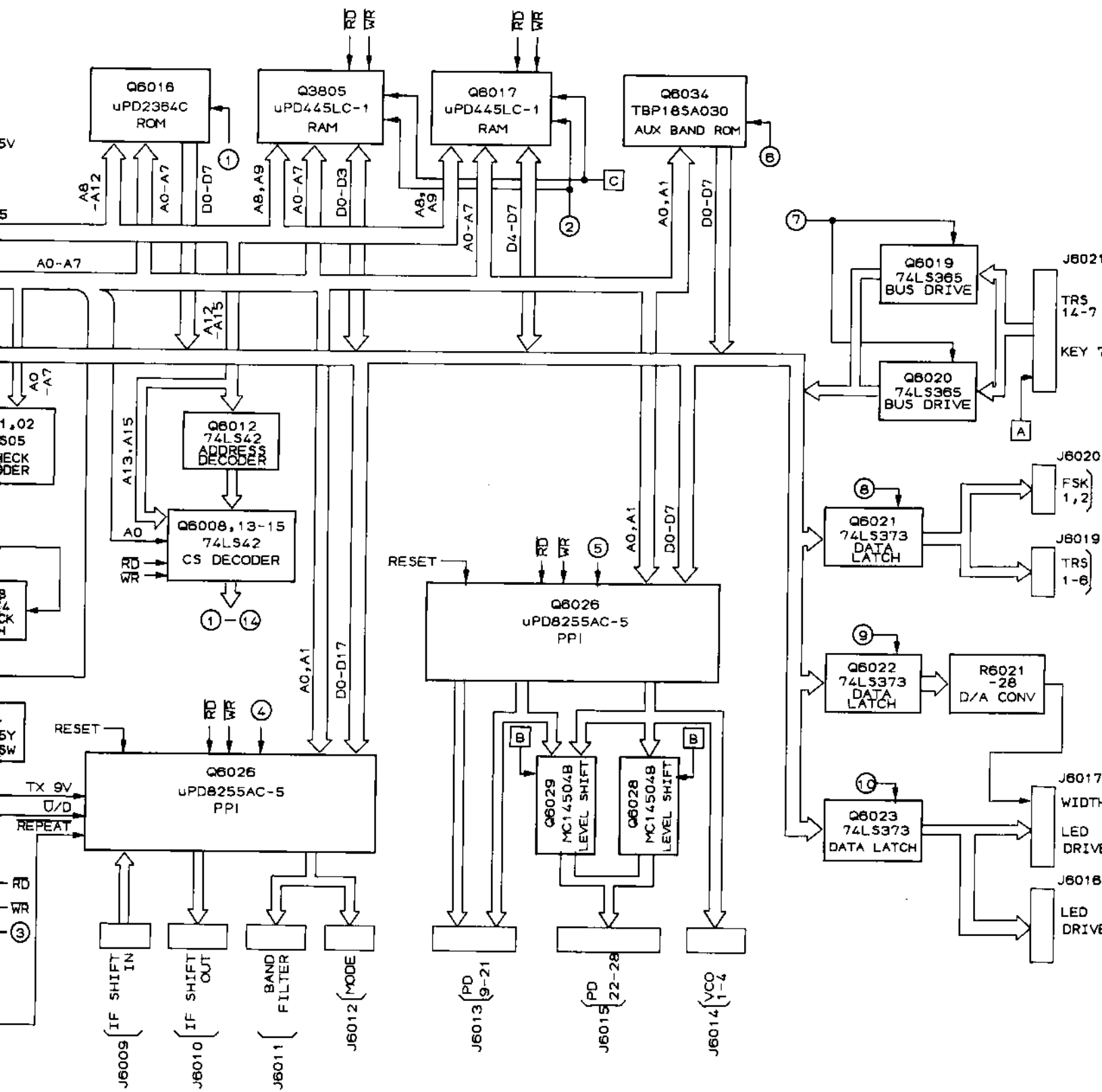

FT-980
CPU BOARD BLOCK DIAGRAM

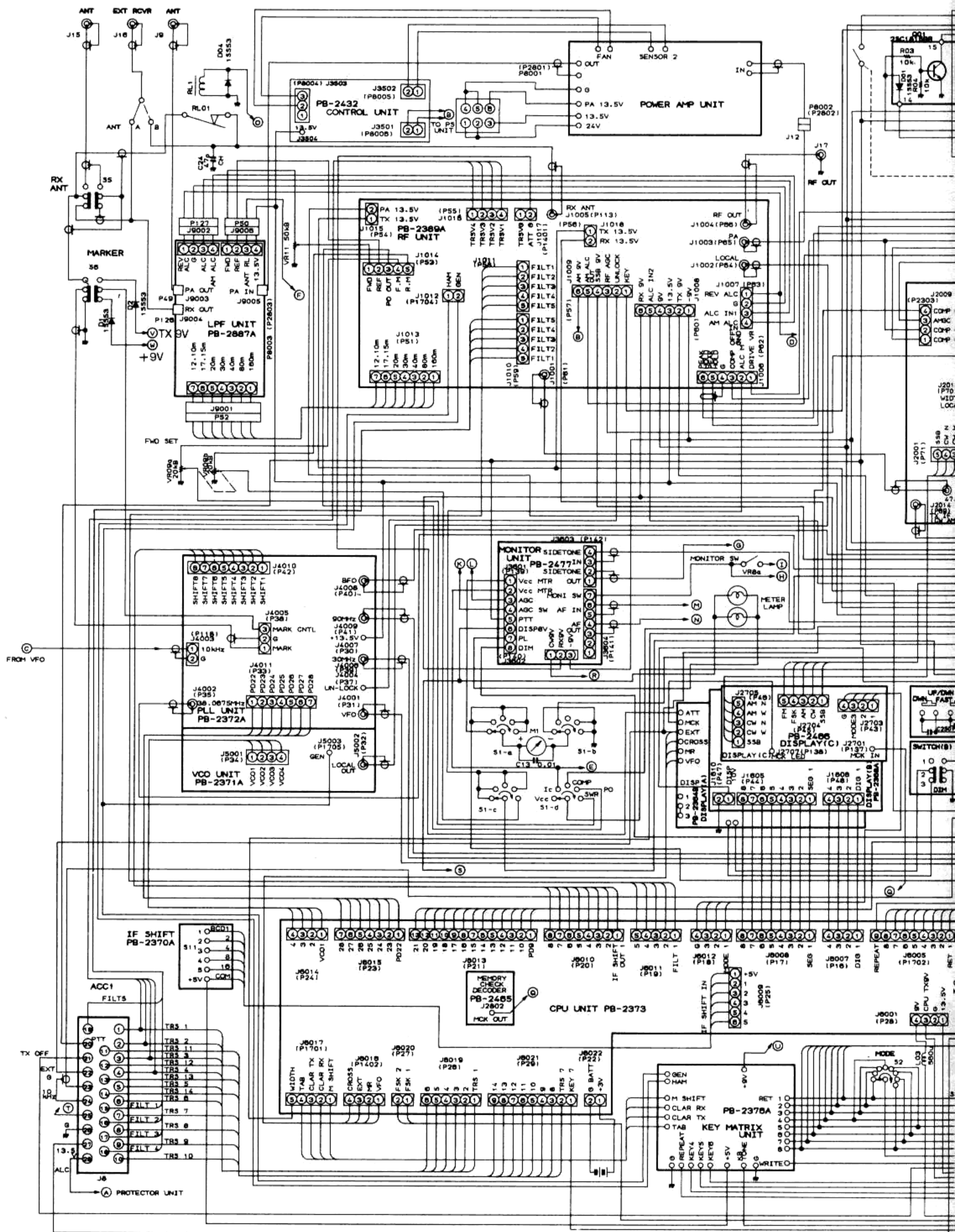

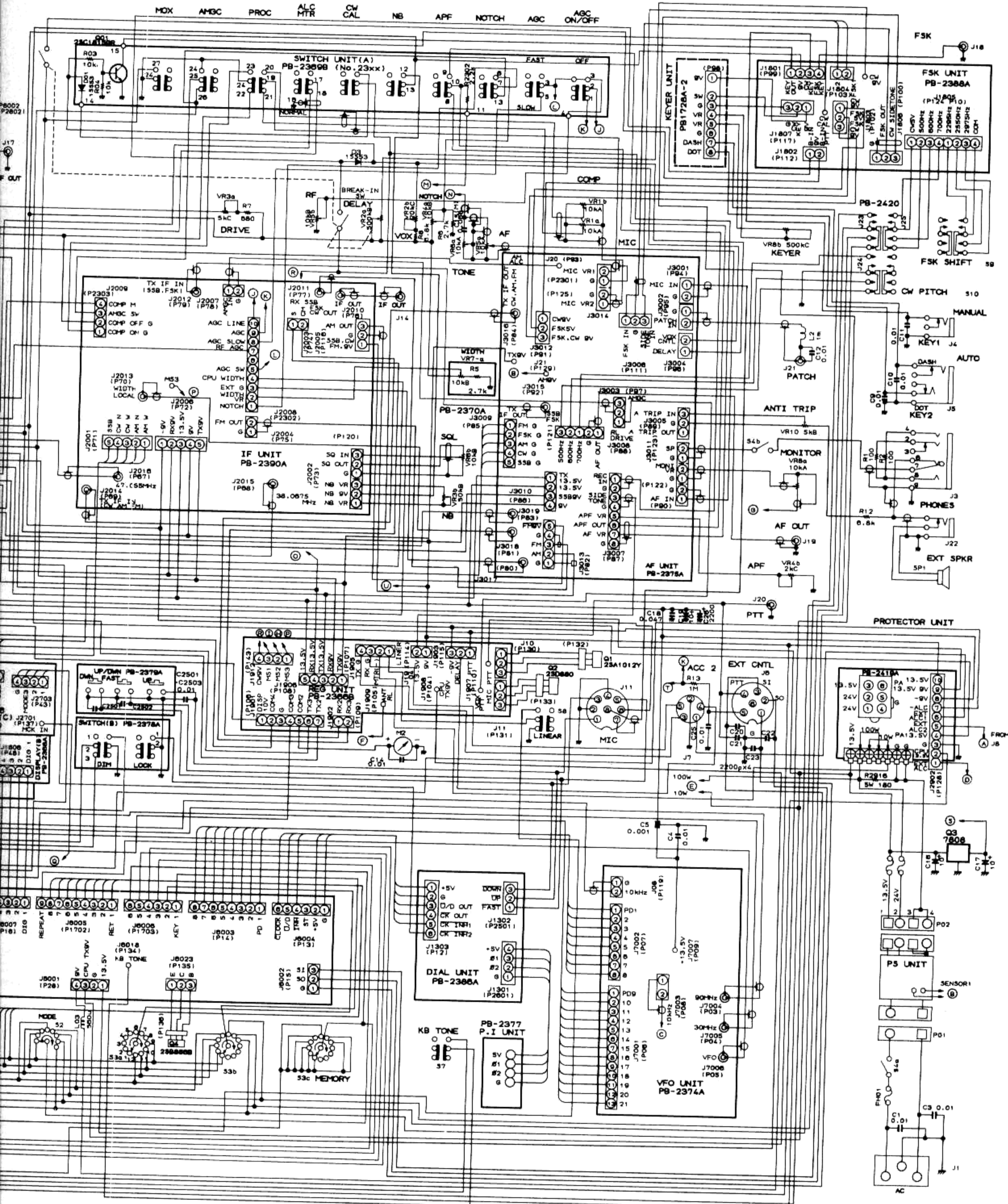

FT-980 CONNECTION DIAGRAM

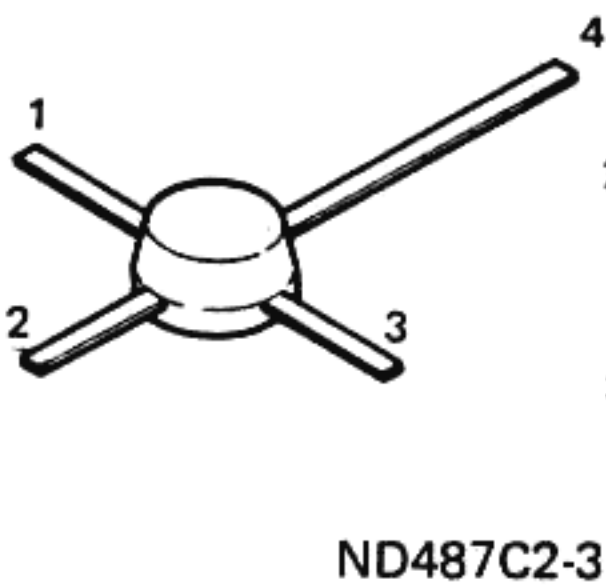
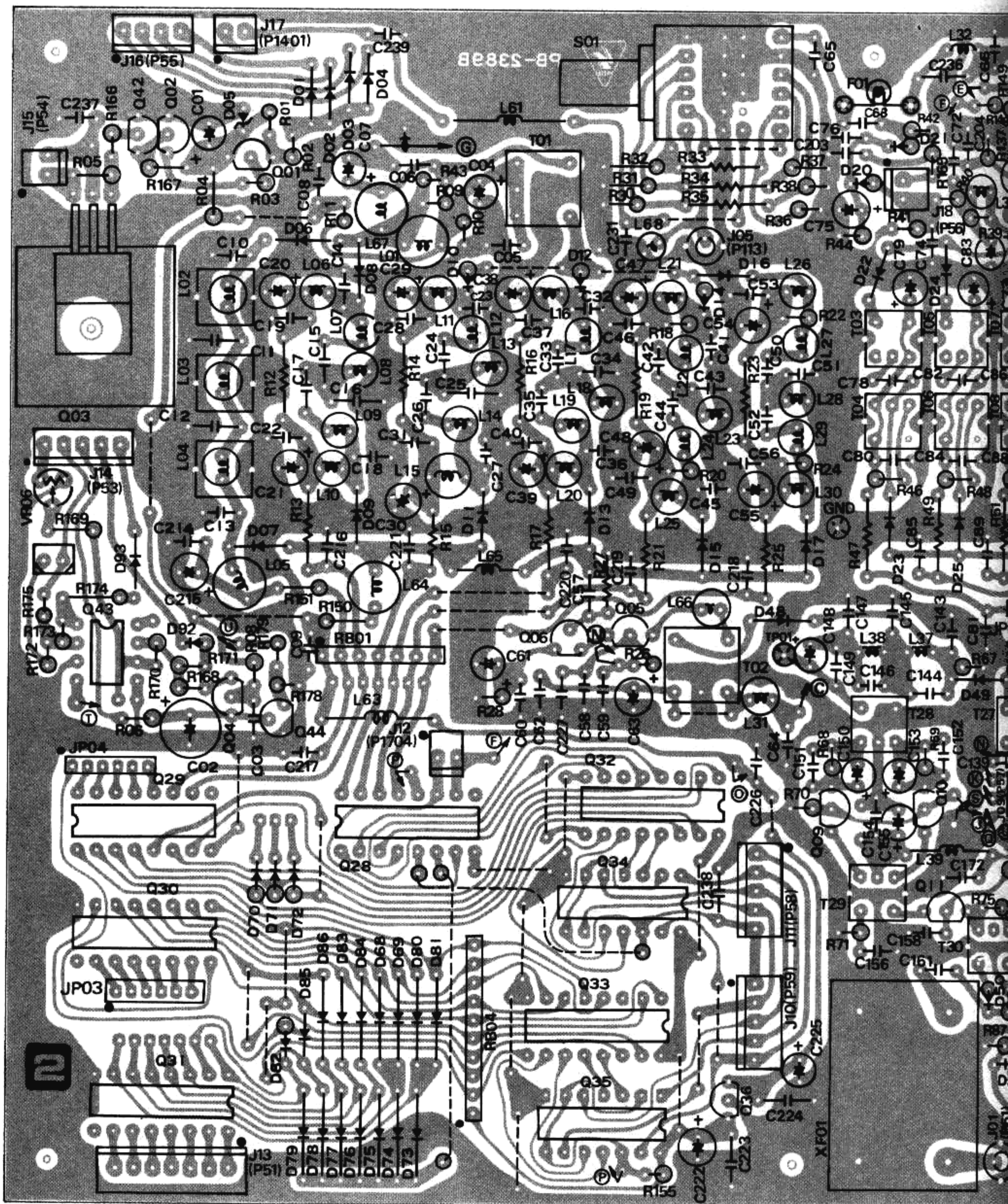

ND487C2-3R

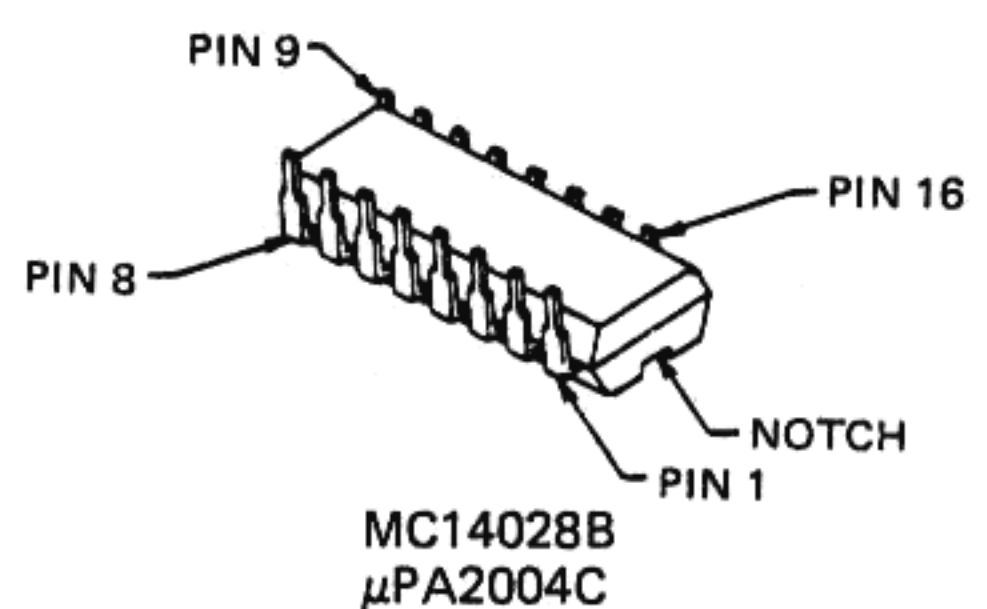

MC14028B
μPA2004C

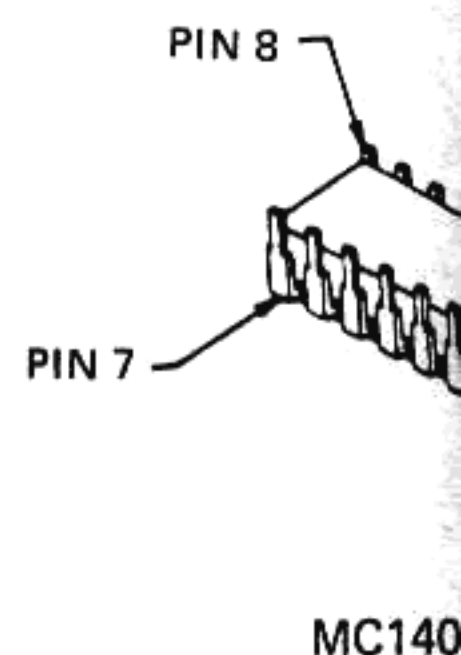

MC140

RF UNIT PARTS LAYOUT (component side)

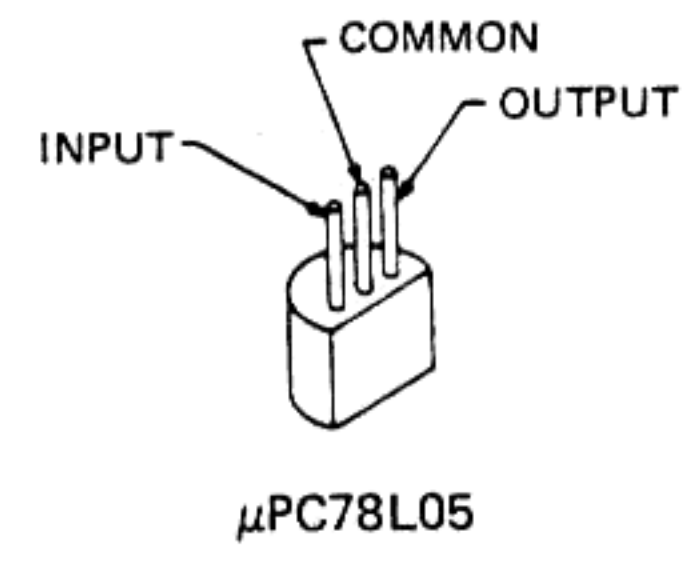
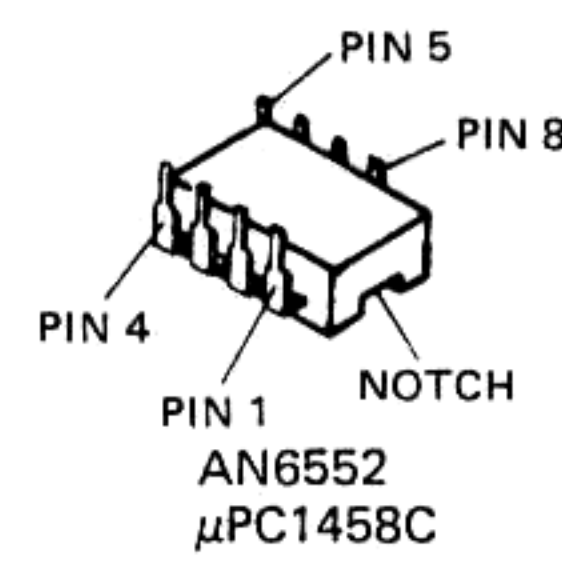
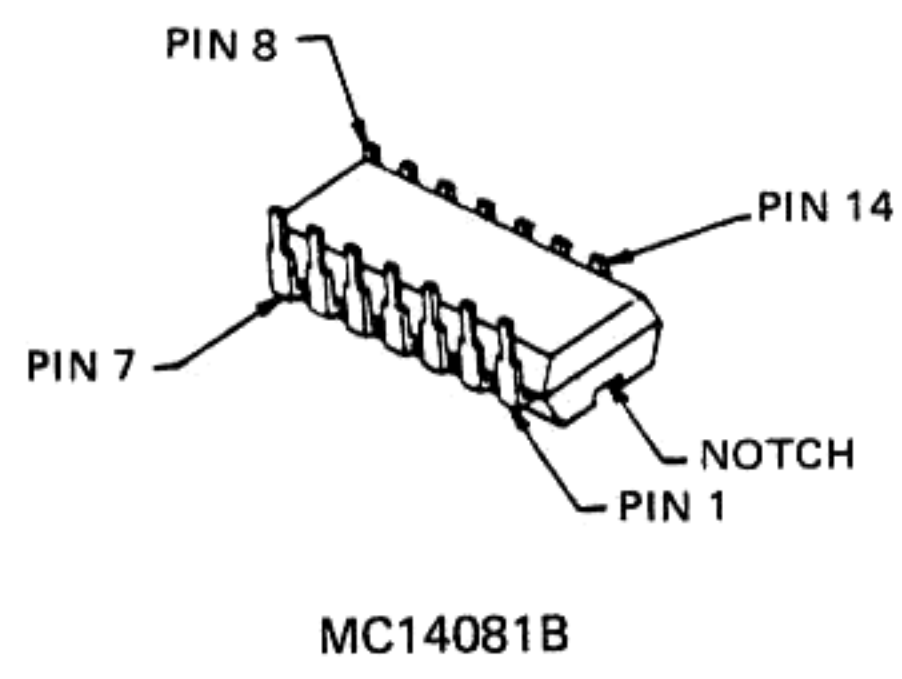
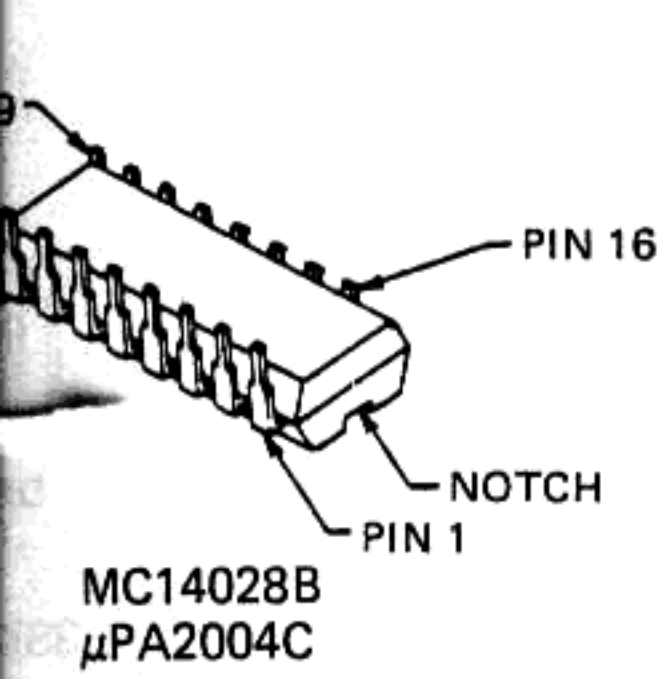
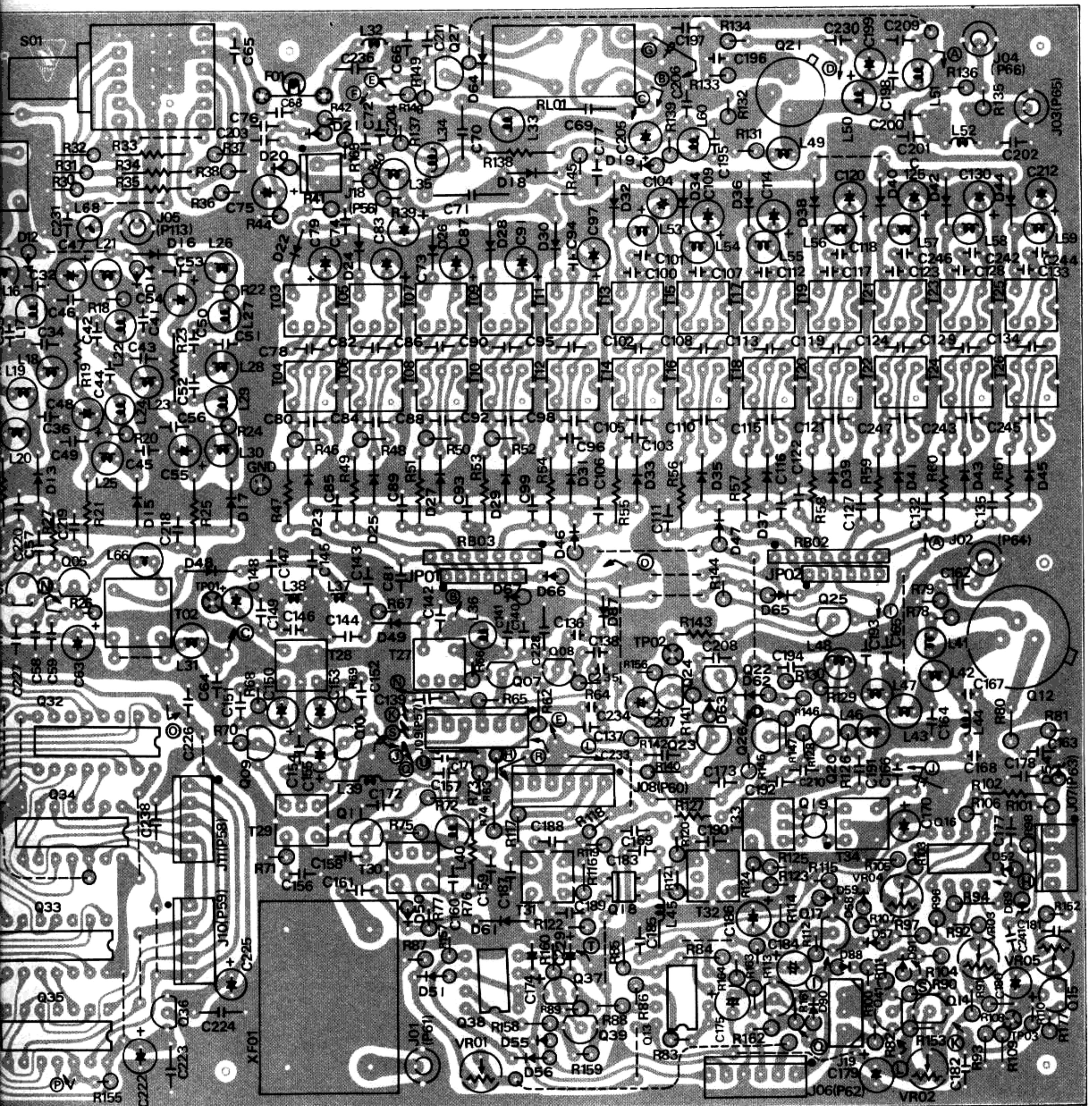

RF UNIT PARTS LAYOUT (solder side)

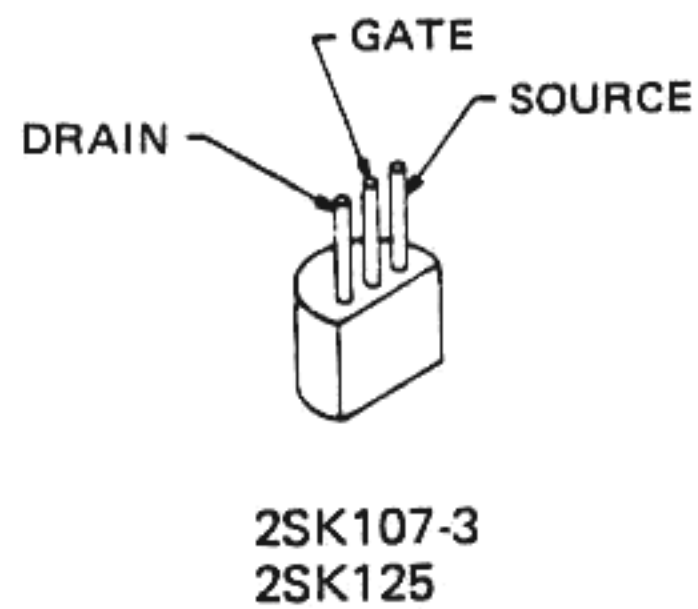
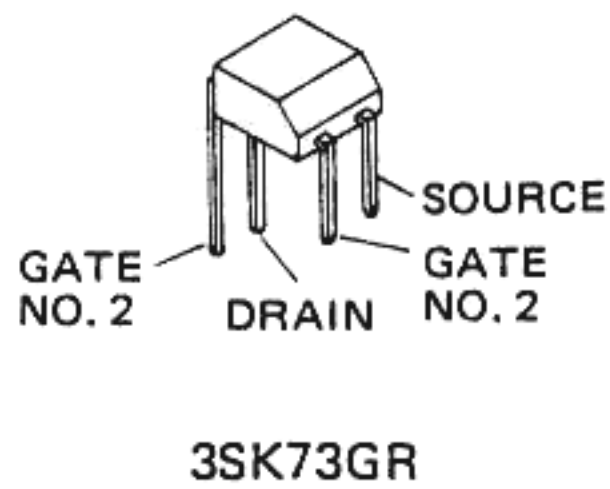
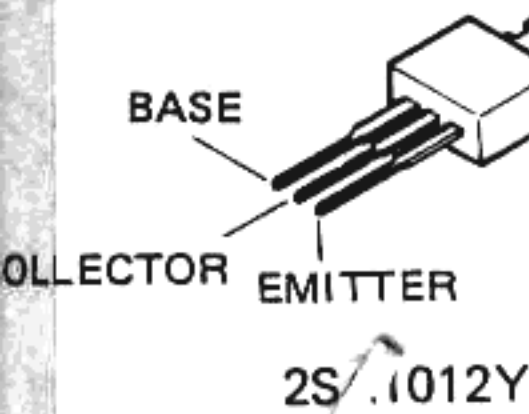
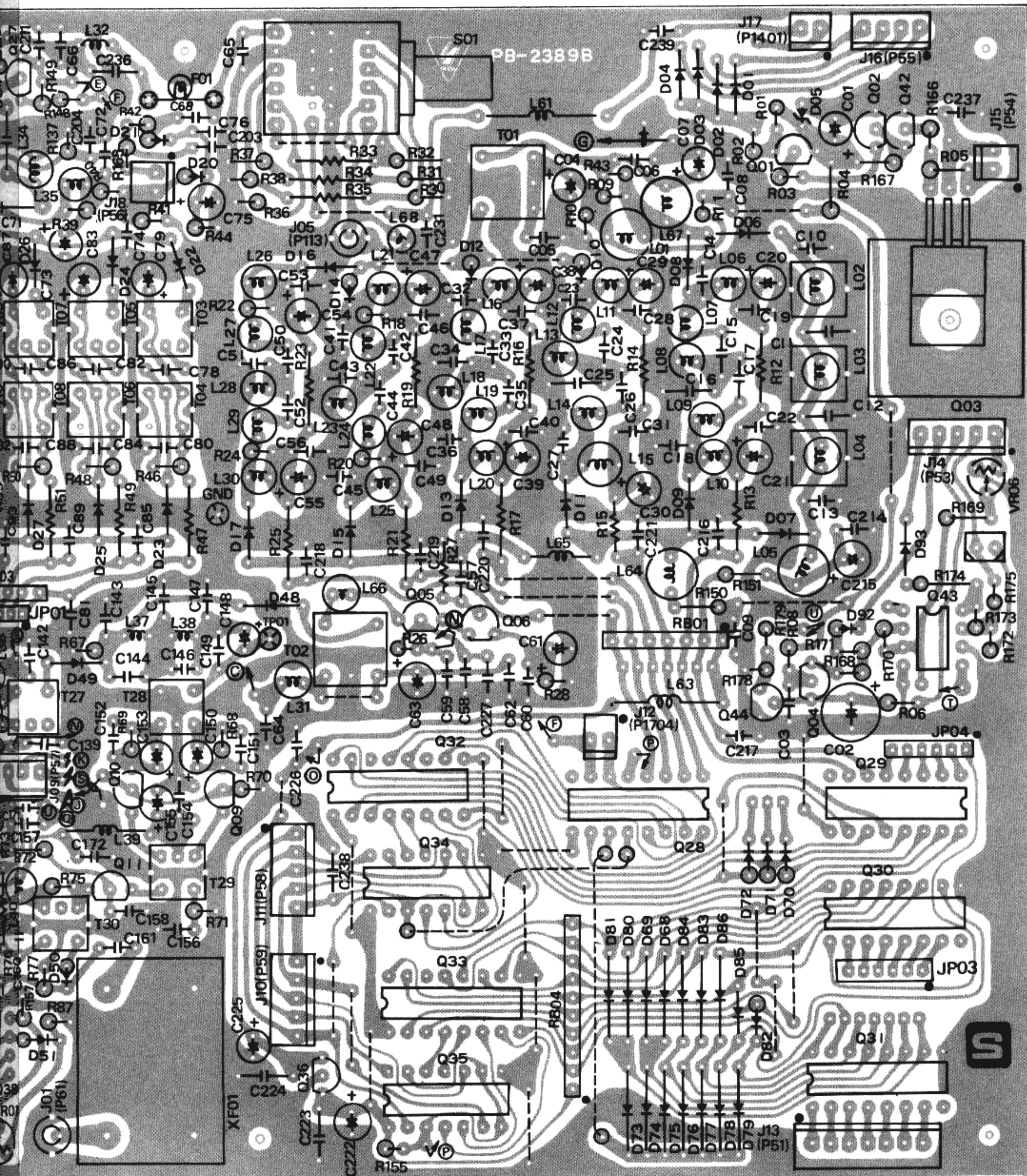

RF UNIT PARTS LAYOUT (solder

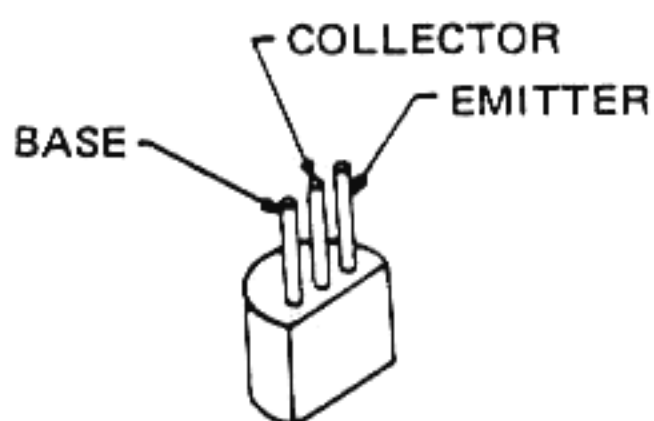
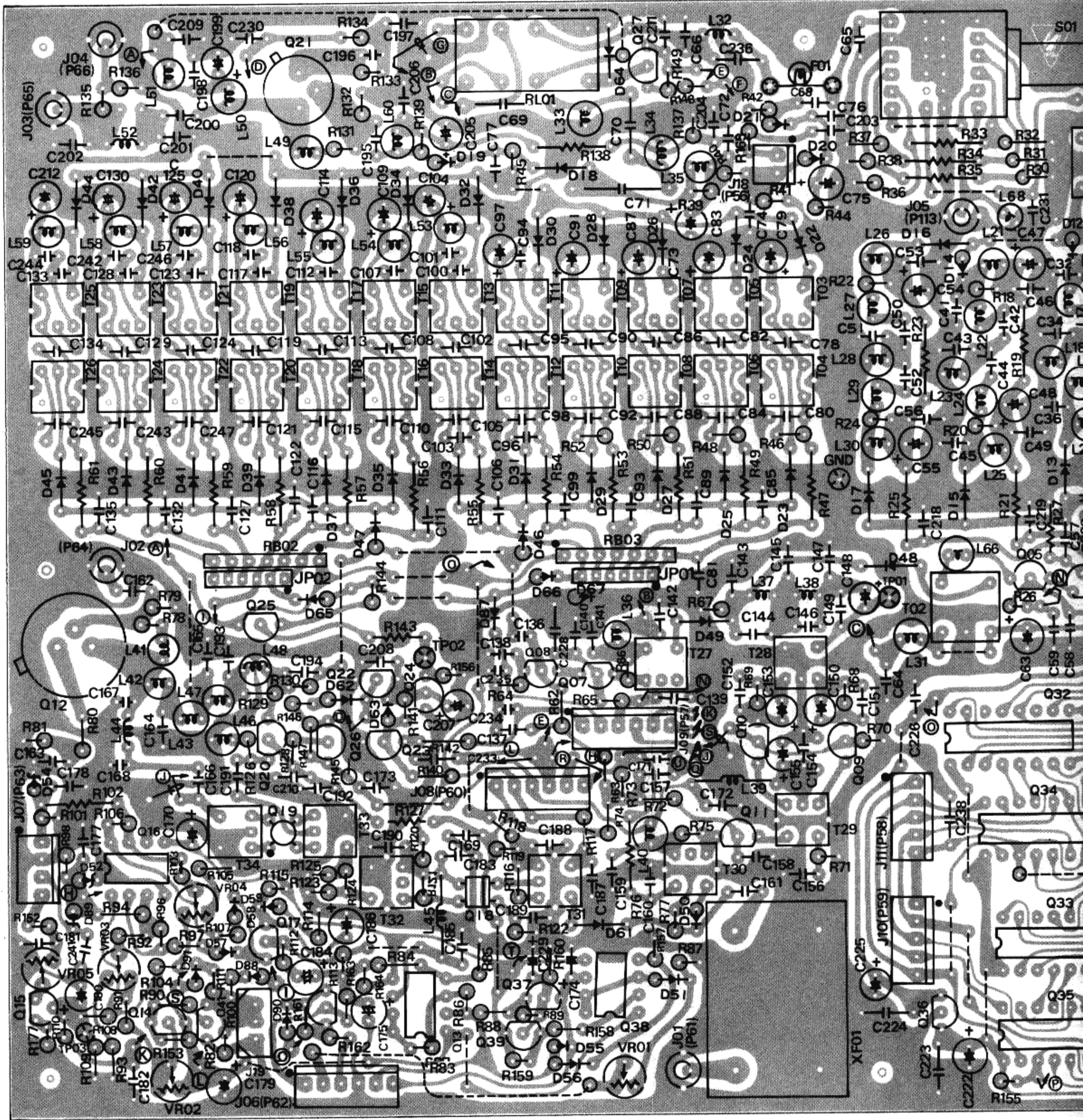

2SA733AP
2SC1815Y
2SC1815GR
2SC1959Y

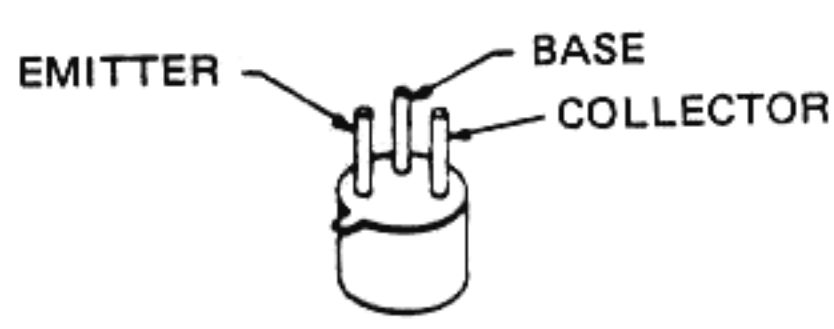

2N4427

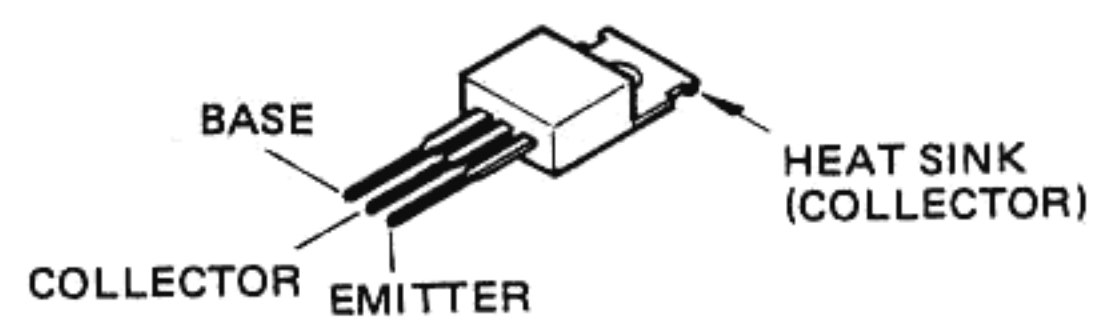

2SA1012Y

GATE NO. 2

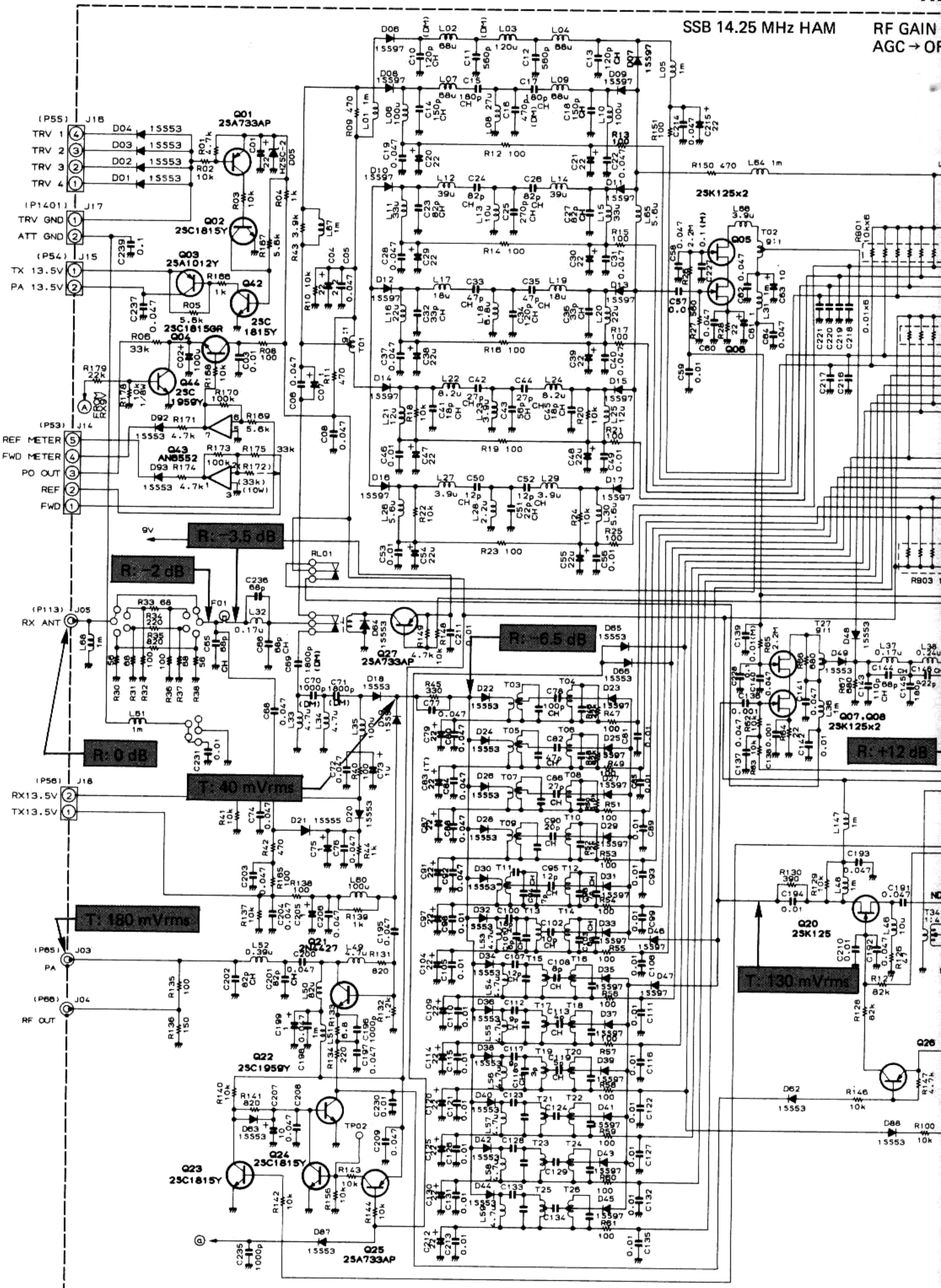

RF UNIT

HAM RF GAIN → MAX COMP → OFF DRIVE → MIN
 AGC → OFF NB → OFF

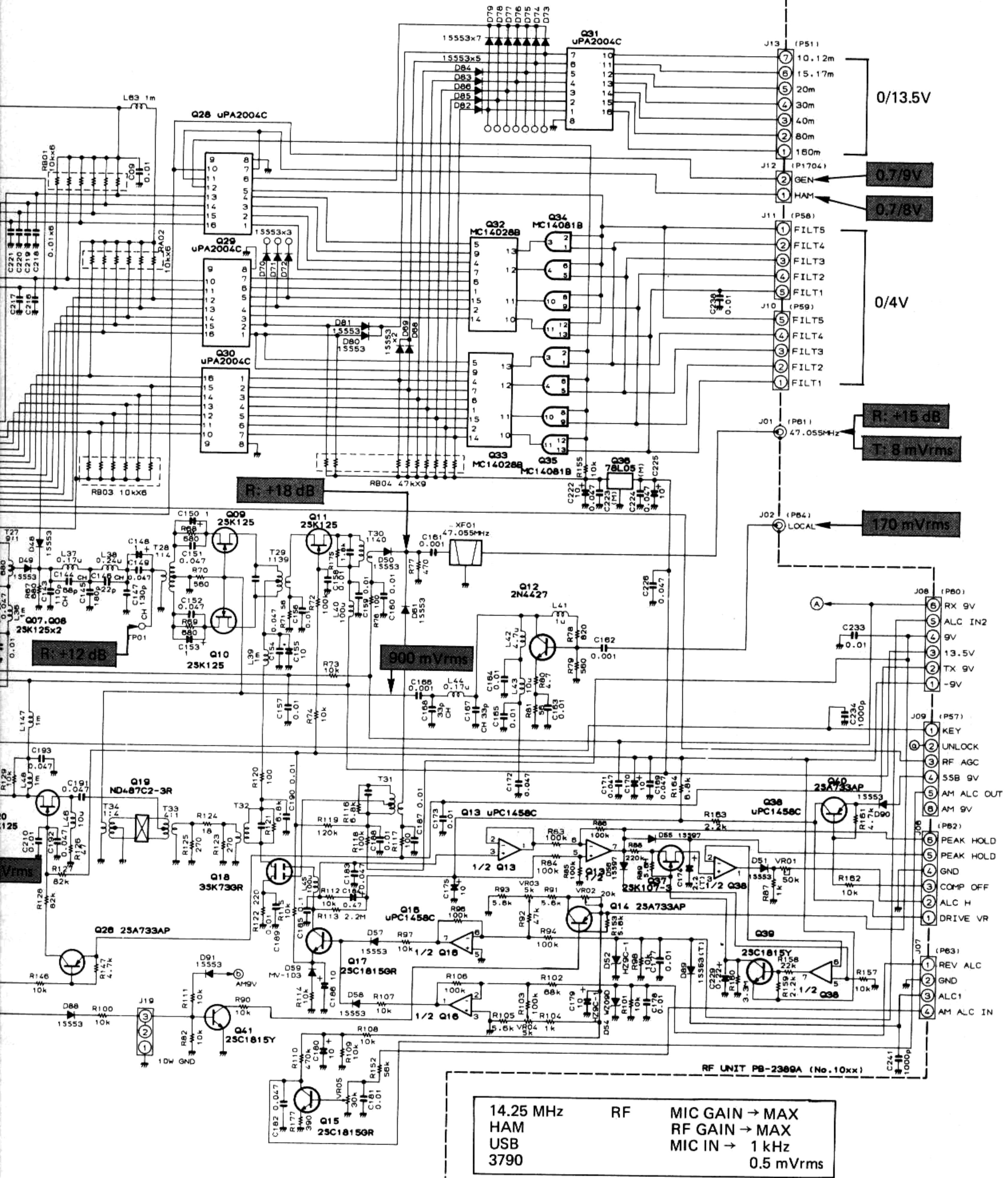

14.25 MHz RF MIC GAIN → MAX
 HAM RF GAIN → MAX
 USB MIC IN → 1 kHz
 3790 0.5 mVrms

RF UNIT VOLTAGE CHART

(DC VOLTS)

	E (S)		C (D)		B (G1)		(G2)		REMARKS
	R	T	R	T	R	T	R	T	
Q1001	5.2		0		5.2				
Q1002	0		0.7		0				
Q1003	0	13.5	0	13.5	0	13			
Q1004	0		13.5		0				
Q1005	4.2		13.5		3				GEN
Q1006	0.7		4.3		0				GEN
Q1007	4.2	7	13.5	13.5	3	3			
Q1008	0.7	0	4.3	7	0	-8			
Q1009	3.5		13.5		0				
Q1010	3.5		13.5		0				
Q1011	1.3		13.5		0				
Q1012	5.5		13.5		5.5				
Q1014	9.5		9.5		9				
Q1015	0		4.5		0				AM
Q1017	-5.5		3.5		-4.5				
	-5.5		-0.7		-4.5				AM
Q1018	1.4		13.5		1		3.5		
	0		13.5		1		-0.7		AM
Q1020	0	1.2	13.5	13	-9	0			
Q1021	7		13.5		7.5				
Q1022	0		0		0.7				
Q1023	0		1.3		0				
Q1024	0		0.7		0				
Q1025	13.5		0		13				
Q1026	-0.7	9	-9	9	-0.7	8.3			
Q1027	9.5		9.5		8.8				GEN
Q1036	IN 13.5		COM 0		OUT 5				
Q1037	0	0-3	0	0-3	0	0-1			
Q1039	-9		0		-9				
Q1040	8.2		8.1		7.5				
Q1041	0		0		0.7				
Q1042	0		0		0.7				
Q1044	0	0	0	0	0.7	-2.5			

RF UNIT VOLTAGE CHART

(DC VOLTS)

	1	2	3	4	5	6	7	8	9	10	11	12	13	14	15	16	REMARKS
Q1013	-	-	-	-9	-	-	-	9									
Q1016	-	-	-	-9	-	-	-	9									
Q1028	-	-	-	-	-	-	-	0	13	-	-	-	-	-	-	-	
Q1029	-	-	-	-	-	-	-	0	13	-	-	-	-	-	-	-	
Q1030	-	-	-	-	-	-	-	0	13	-	-	-	-	-	-	-	
Q1031	-	-	-	-	-	-	-	0	13	-	-	-	-	-	-	-	
Q1032	-	-	-	-	-	-	-	0	-	-	-	-	-	-	-	5	
Q1033	-	-	-	-	-	-	-	0	-	-	-	-	-	-	-	5	
Q1034	-	-	-	-	-	-	0	-	-	-	-	-	-	5			
Q1035	-	-	-	-	-	-	0	-	-	-	-	-	-	5			
Q1038	-	-	-	-9	-	-	-	9									
Q1043	-	-	-	-9	-	-	-	9									

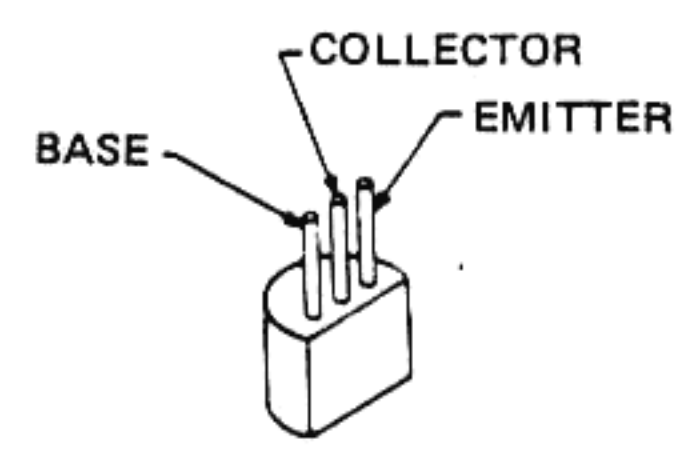
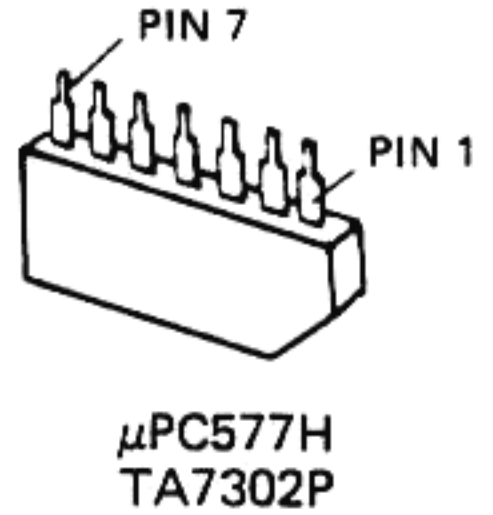
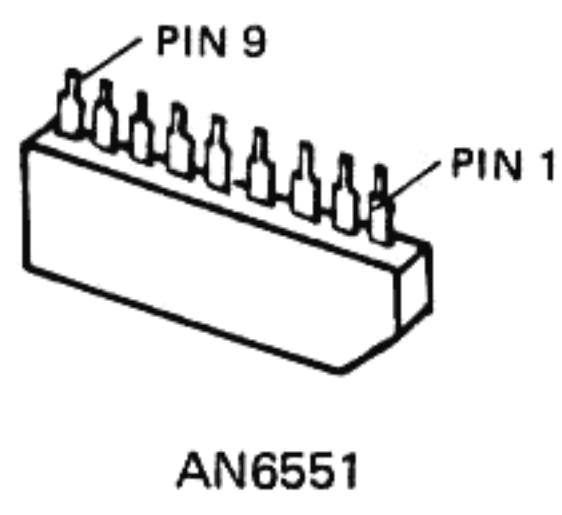
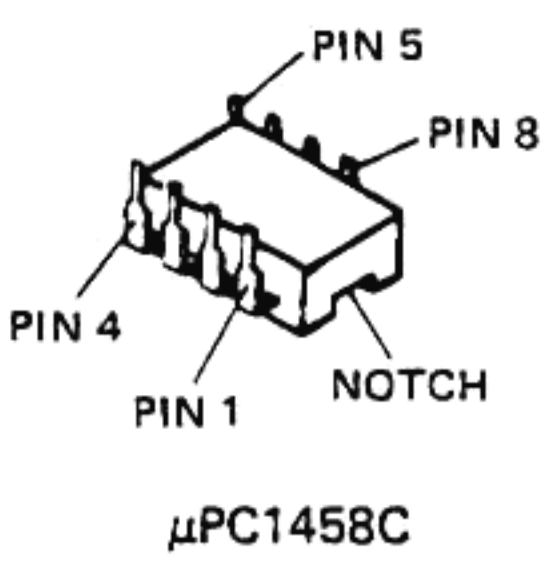
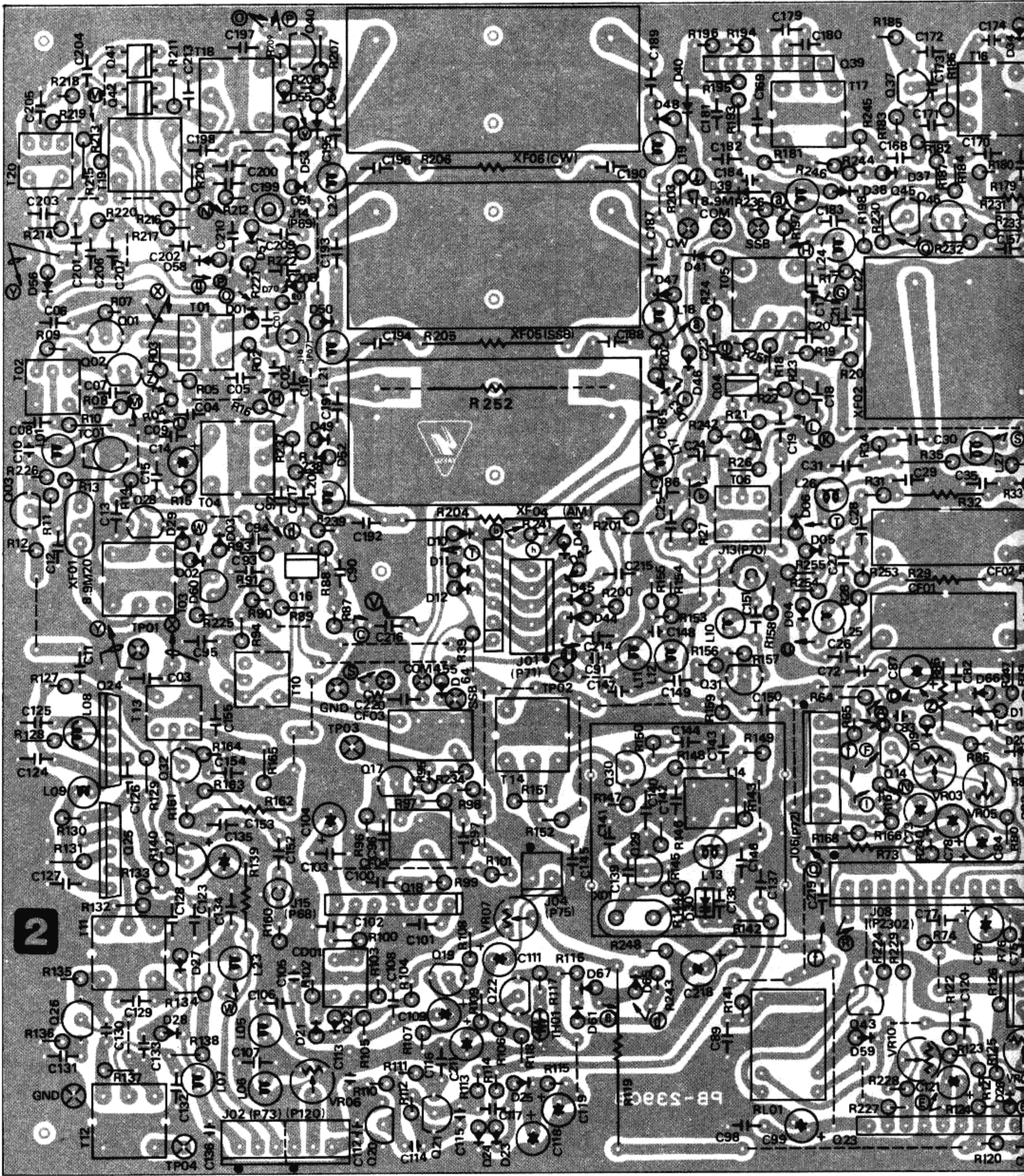

- 2SA733
- 2SB774
- 2SC380
- 2SC181
- 2SC181
- 2SC181
- 2SC192
- 2SC195

IF UNIT PARTS LAYOUT (component side)

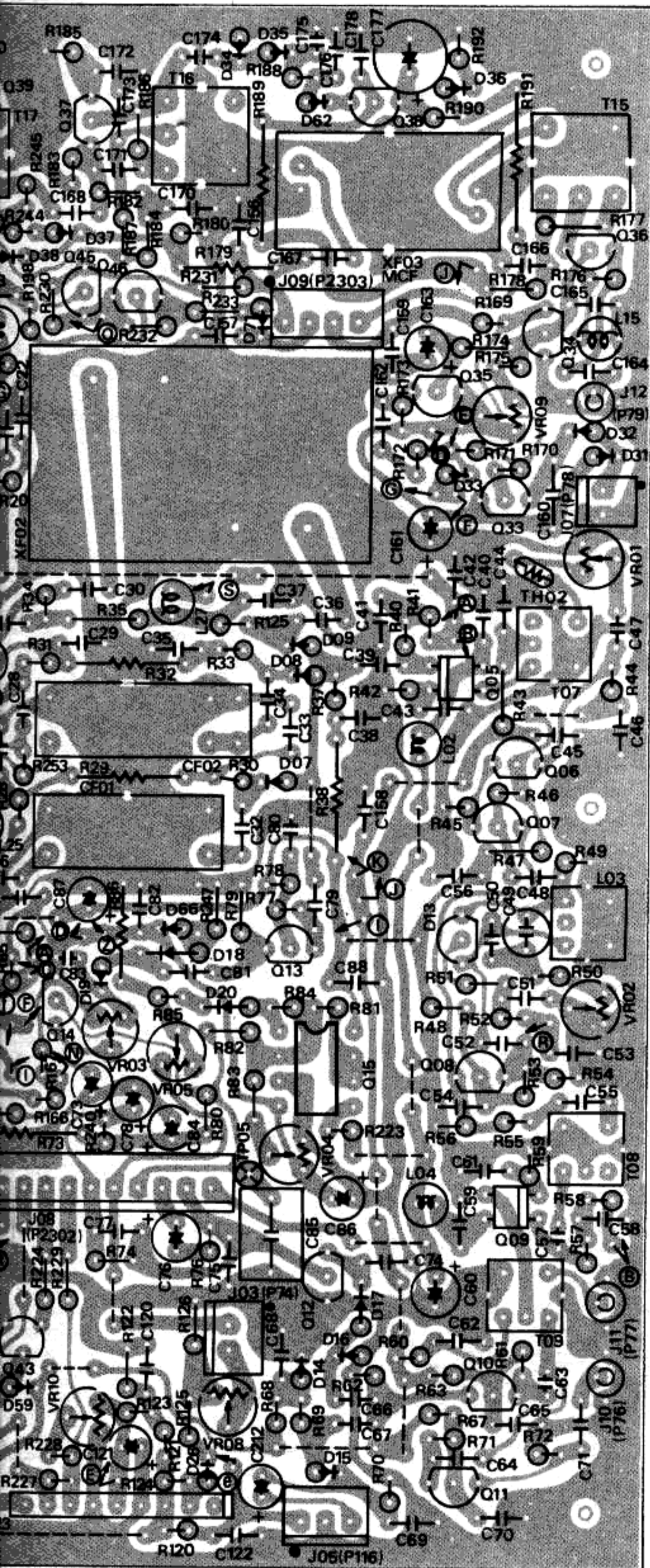

IF UNIT VOLTAGE CHART

(DC VOLTS)

	E (S)		C (D)		B (G1)		(G2)		REMARKS
	R	T	R	T	R	T	R	T	
Q2001	1.5		13		-	-	-		
Q2002	1.5		13		-	-			
Q2003	5.5		11.5		6.2				
Q2004	1.3	0	13.5	13.5	1.3	-5.5	-		
	1.3	1.3	13.5	13.5	1.3	1.3	-		MONI → ON
Q2005	1.2	0	13	13.5	1.3	-5.5	2.5	2.5	
	1.2	1.2	13	13	1.3	1.3	2.5	2.3	MONI → ON
Q2006	3.1		8.8		3.7				
Q2007	3.1		8.8		3.7				
Q2008	4.3		8.8		3.7				
Q2009	1.3	0	13	13.5	1.3	-5.5	3	3	
	1.3	1.2	13	13	1.3	1.3	3	3	MONI → ON
Q2010	5.3		11.8		6				
Q2011	5.6		11.8		6.3				
Q2012	0		2.4		0				
Q2013	-4		7.8		4.5				
Q2014	-9		3.5		-9				
Q2016	1.1	0	9	13.5	1.3	-5.5	-		MONI → OFF FM
	1.1	0.9	9	9	1.3	1.1	-		MONI → ON FM
	2.6	2.6	13.5	13.5	1.3	-5.5	-		MONI → OFF SSB
	2.6	2.6	13.5	13.5	1.3	1.1	-		MONI → ON SSB
Q2017	1.7		4		2.4				
Q2019	1.4		4.2		1.1				FM
Q2020	0		1.5		0.7				
Q2021	4.7		6.2		5.3				
Q2022	0		1.1		0.5				FM
Q2024	8.5	1	9	9	8.8	1.4			NB → ON
	-	-	9	9	8.8	1.4			NB VR → MIN
Q2025	8.5	0.8	9	9	8.8	1.4			NB → ON
	-	-	9	9	8.8	1.8			NB VR → MIN
Q2026	1.0		9.5		1.7				NB → ON
Q2027	0		9.5		0.2				NB VR → MIN
Q2028	0	0	7	0	0	0.4			NB → ON
Q2029	-		9		-				
Q2030	1.2		-		-				
Q2031	-		7.5		-				
Q2032	1.8		-		-				
Q2033	-9.5	-9.5	4.3	-0.7	-9	-9			AM GC → OFF
	-9.5	-9.5	6.4	0	-9	-9			AM GC → ON
Q2034	0	0	-9	0	4.4	-0.7			
	0	0	-9	-9	6.5	0			AM GC → ON

- COLLECTOR 2SA733AD
- EMITTER 2SB774
- 2SC380Y
- 2SC1815Y
- 2SC1815GR
- 2SC1815BL
- 2SC1923R
- 2SC1959Y

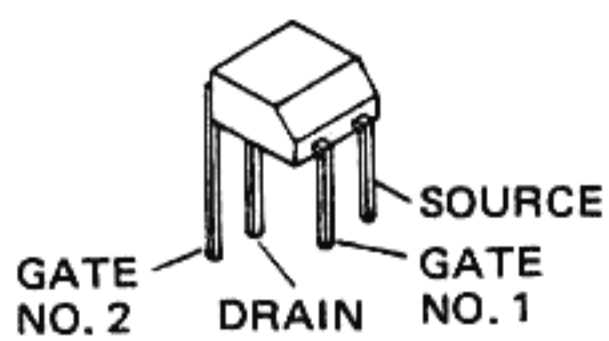
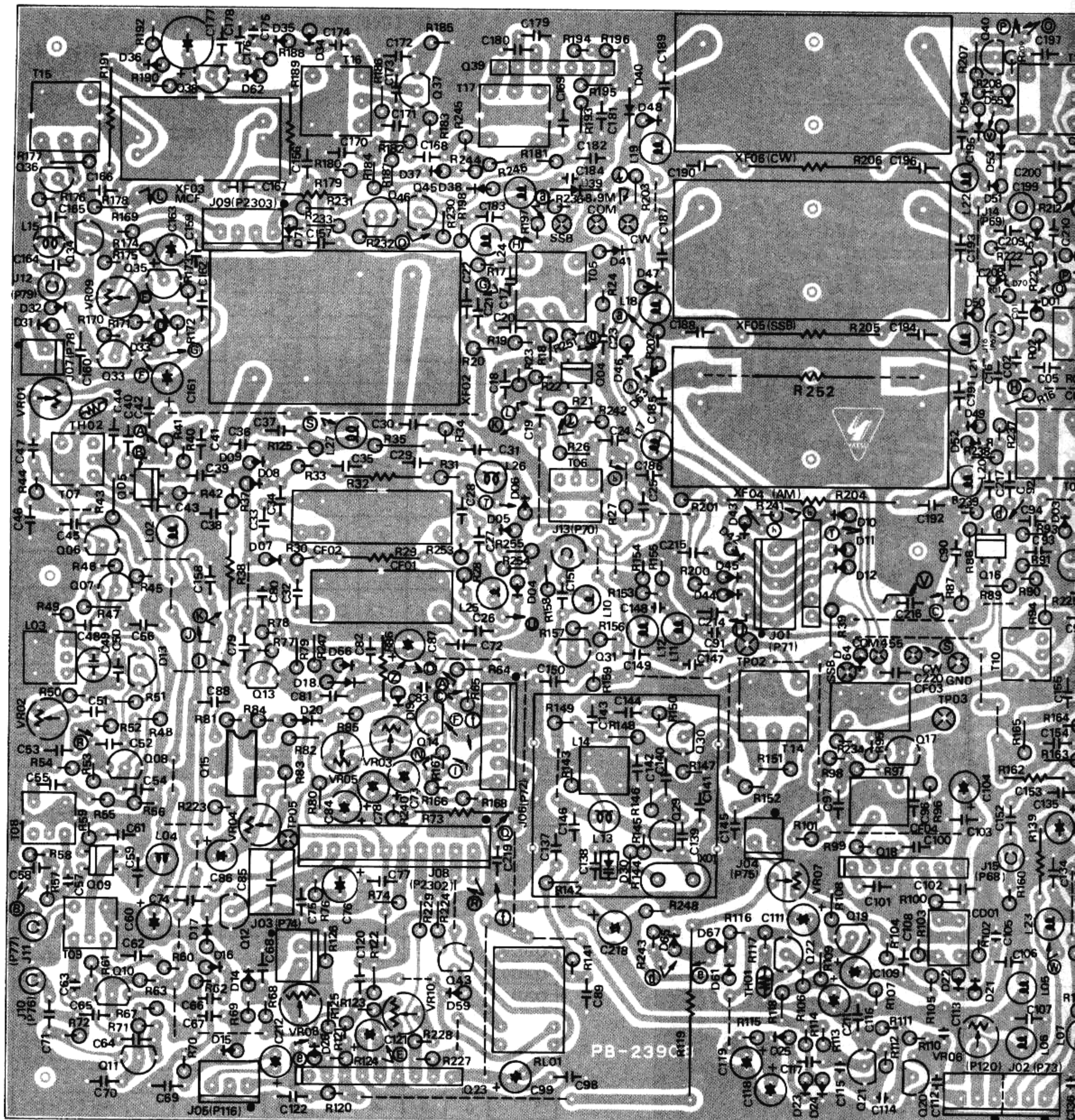

3SK73GR

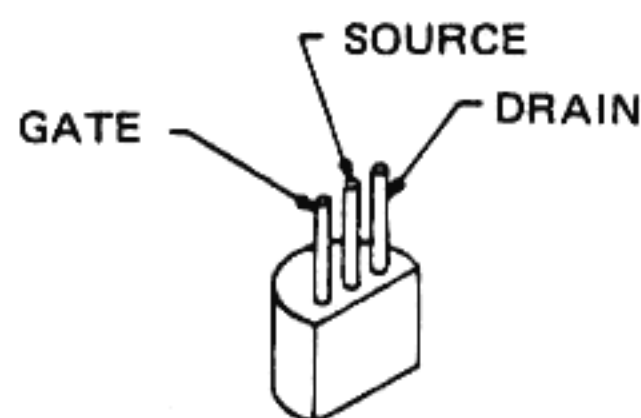

2SK19TMGR

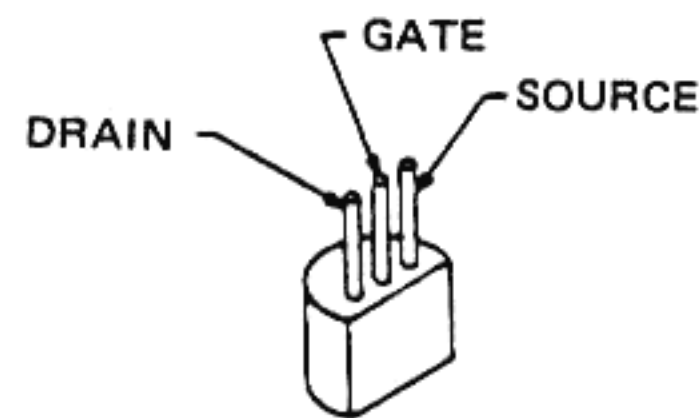

2SK125

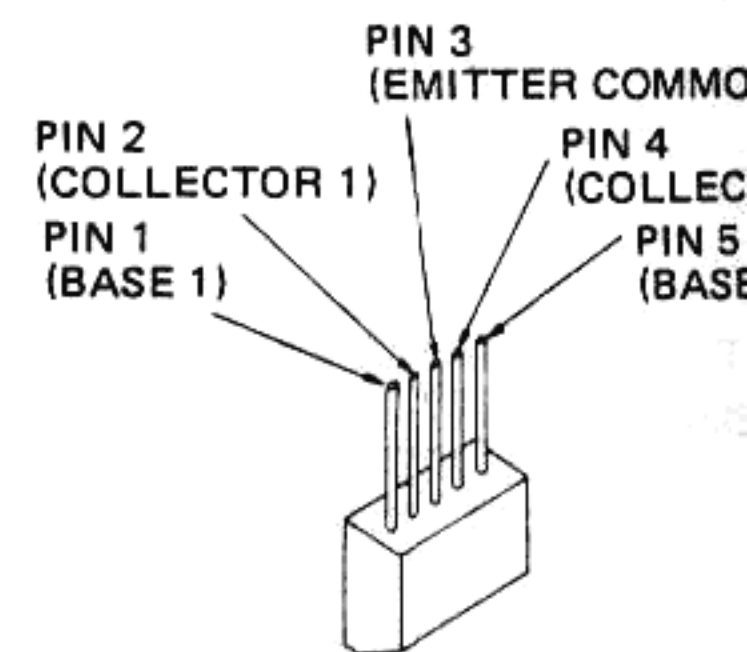

2SC1583G

IF UNIT PARTS LAYOUT (solder side)

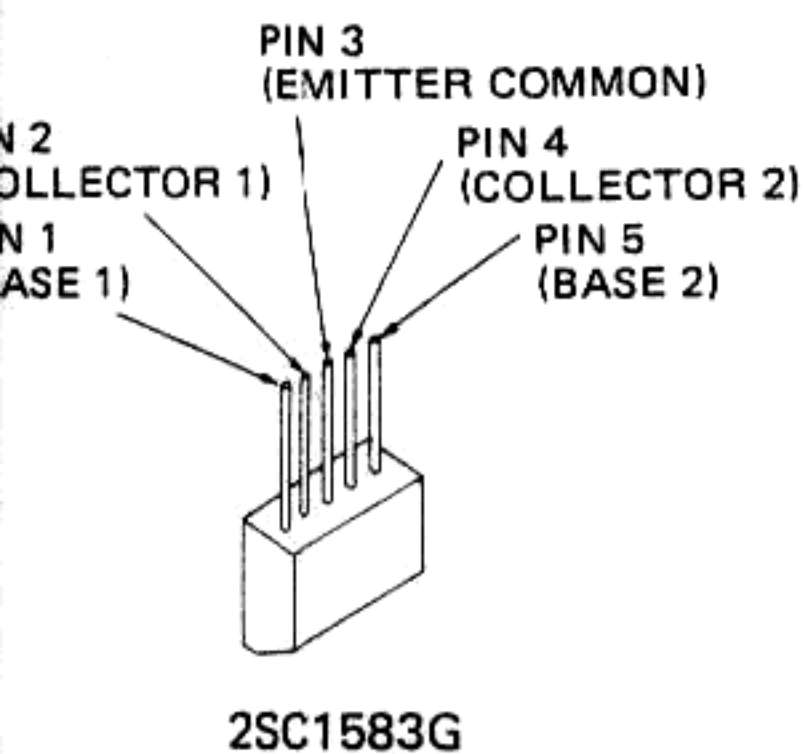
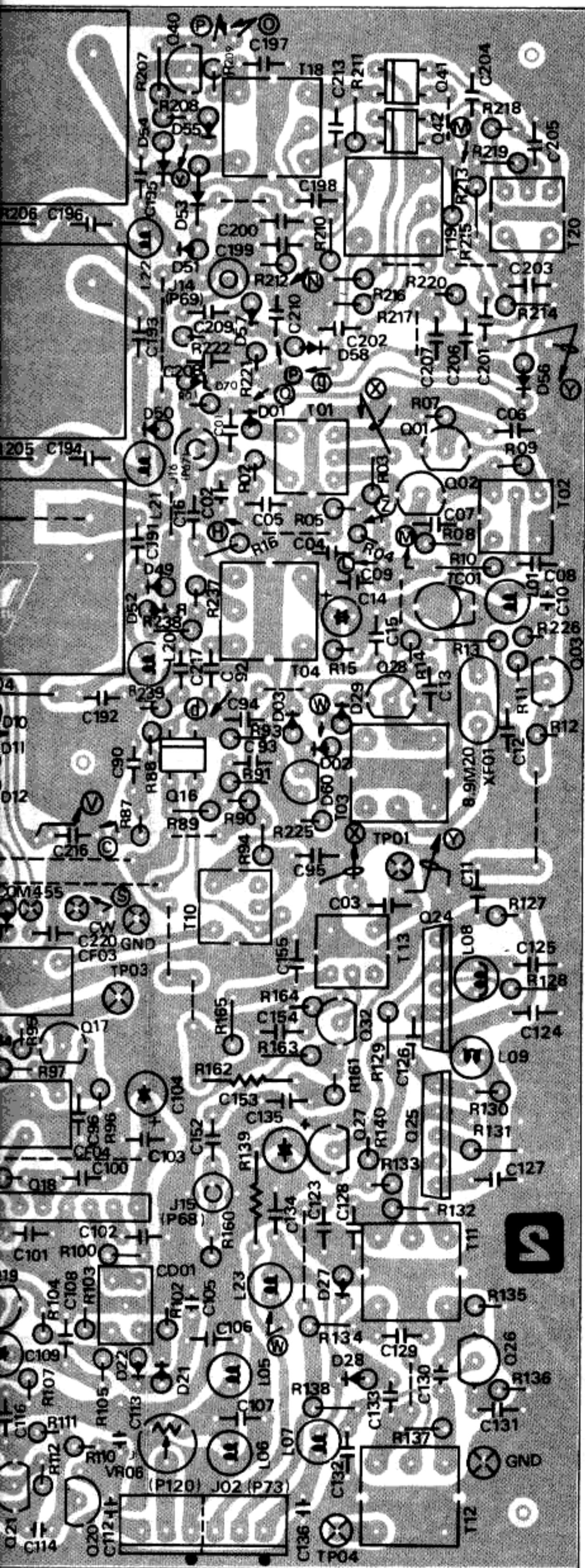

IF UNIT VOLTAGE CHART

(DC VOLTS)

	E (S)		C (D)		B (G1)		(G2)		REMARKS
	R	T	R	T	R	T	R	T	
Q2035	-9.5	-9.5	-9	0	-9	-9			
	-9.5	-9.5	-9	-9	-9	-9			AM GC → ON
Q2036	0	1	13.5	11.5	-9	0			
	0	0	13.5	13.5	-9	-9			AM GC → ON
Q2037	0	0.8	0	9	0	1.4			COMP → ON
Q2038	0		13.5		0				METER SW → COMP
Q2040	-0.7	8	0	8	0	6.4			SSB, FSK
	-0.7	8	-0.2	0	-0.2	0			CW, AM, FM
Q2041	0	-	13.5	12.5	-2.5	-	-	-	
Q2042	0	-	13.5	12.5	-2.5	-	-	-	
Q2043	0		0		0.7				
Q2045	-0.7	9	0	0	-0.7	9			
	-0.4	9	0	9	-0.2	8.3			COMP → ON
Q2046	-0.7	9	0	9	-0.7	8.2			
	-0.4	9	0	9	-0.4	8.2			COMP → ON

IF UNIT VOLTAGE CHART

(DC VOLTS)

	1	2	3	4	5	6	7	8	9	REMARKS
Q2015	-	-	0	-9	-	-	-	9		
Q2018	5.2	-	-	0	-	-	7.8			
Q2023	9	-	-	0	-9	0	-	-	9	
Q2039	-	-	-	0	-	-	7.9			COMP → ON TX

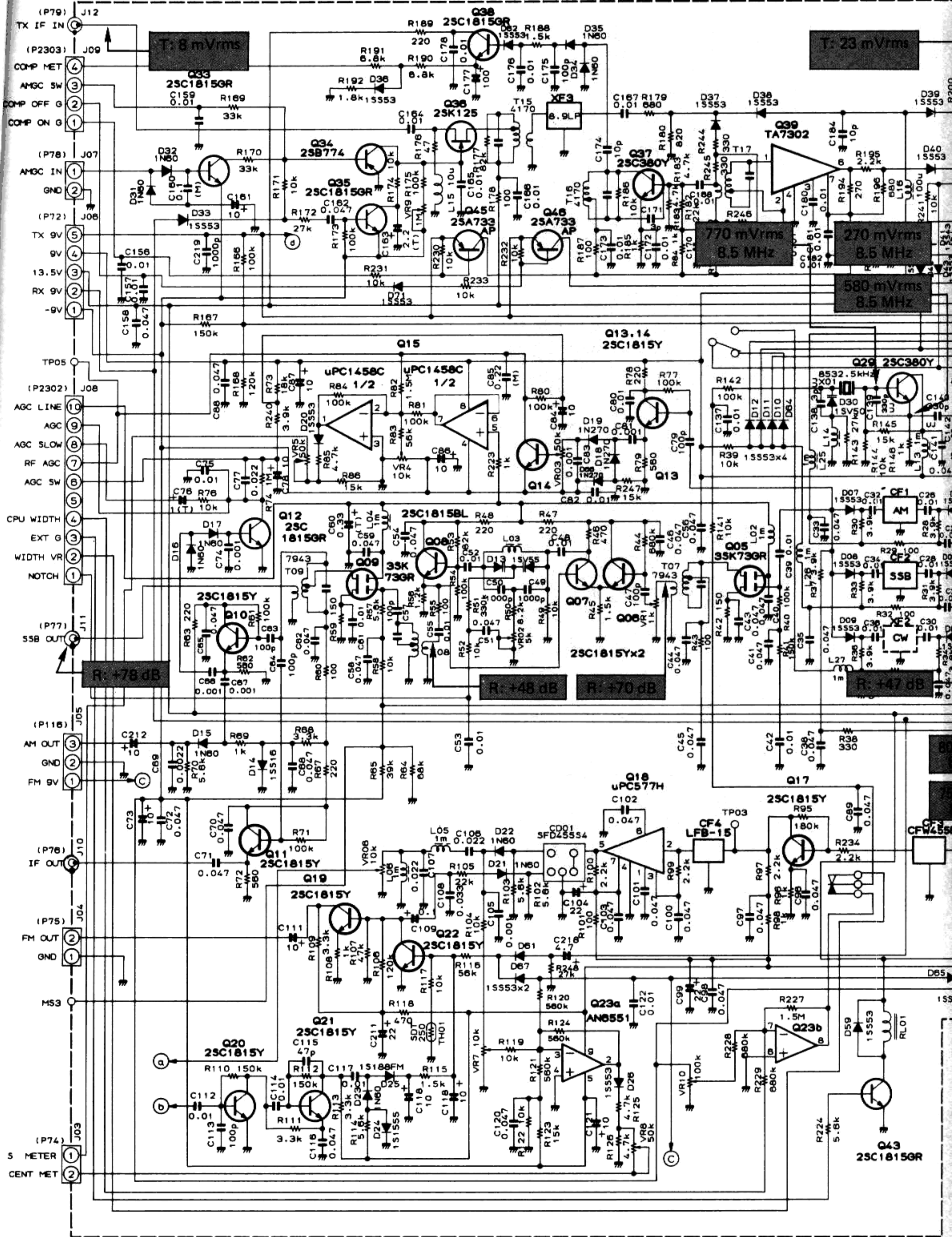

IF UNIT

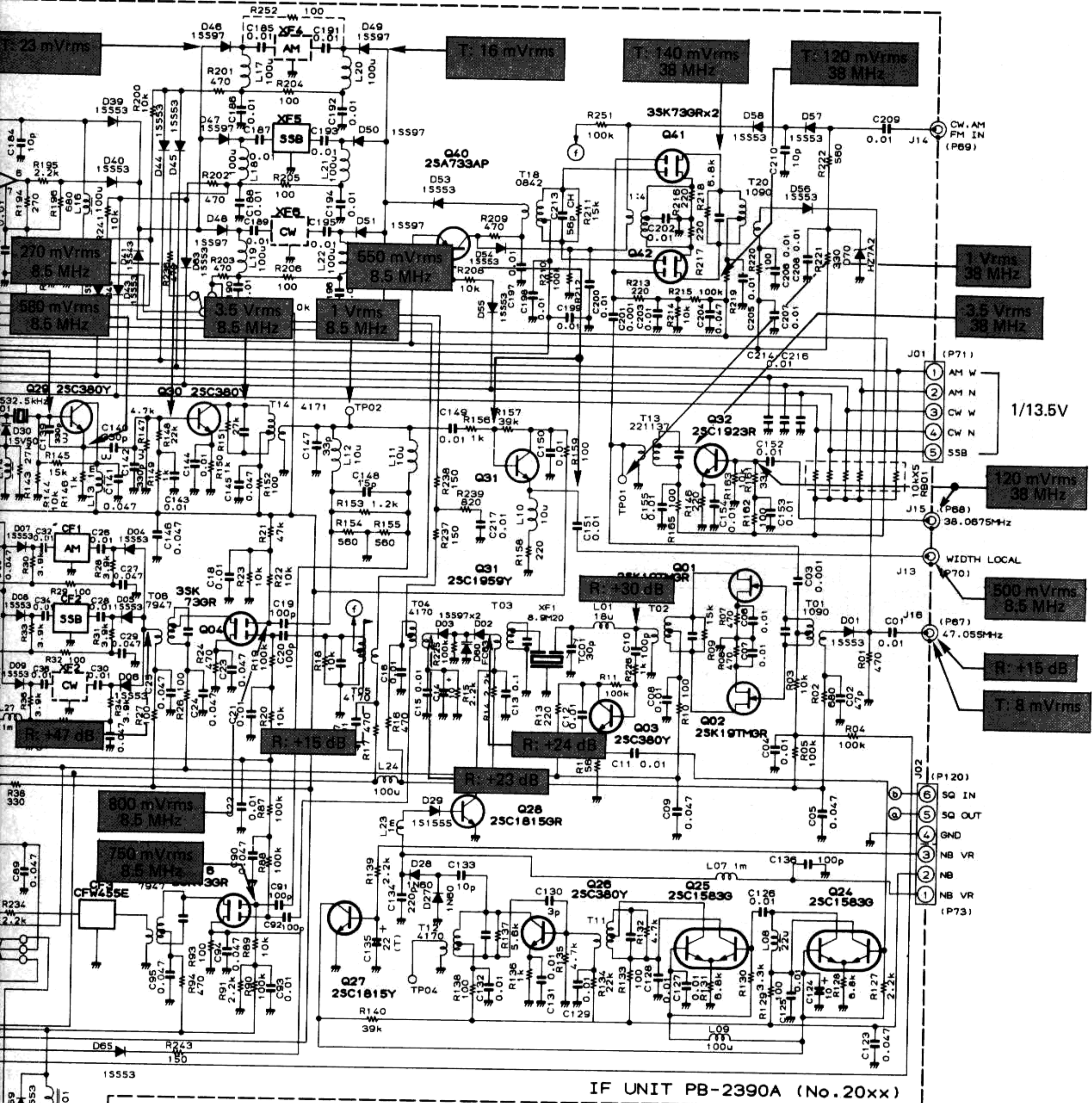

IF UNIT PB-2390A (No. 20xx)

- SSB 14.25 MHz
- ANT → 0 dBμ
- MIC INPUT → 0.5 mVrms (1 kHz)
- MIC GAIN → MAX
- RF GAIN → MAX
- AGC → OFF
- WIDTH VR → CEN

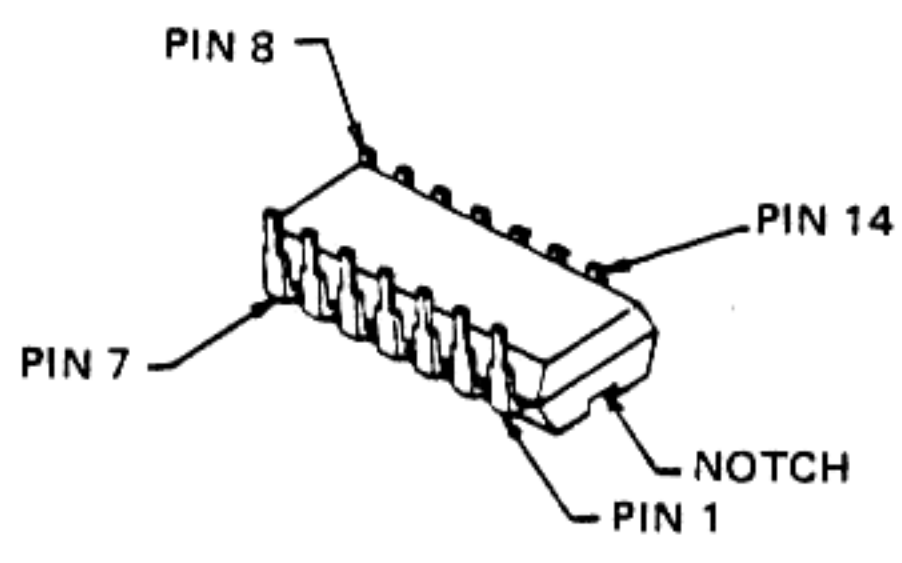
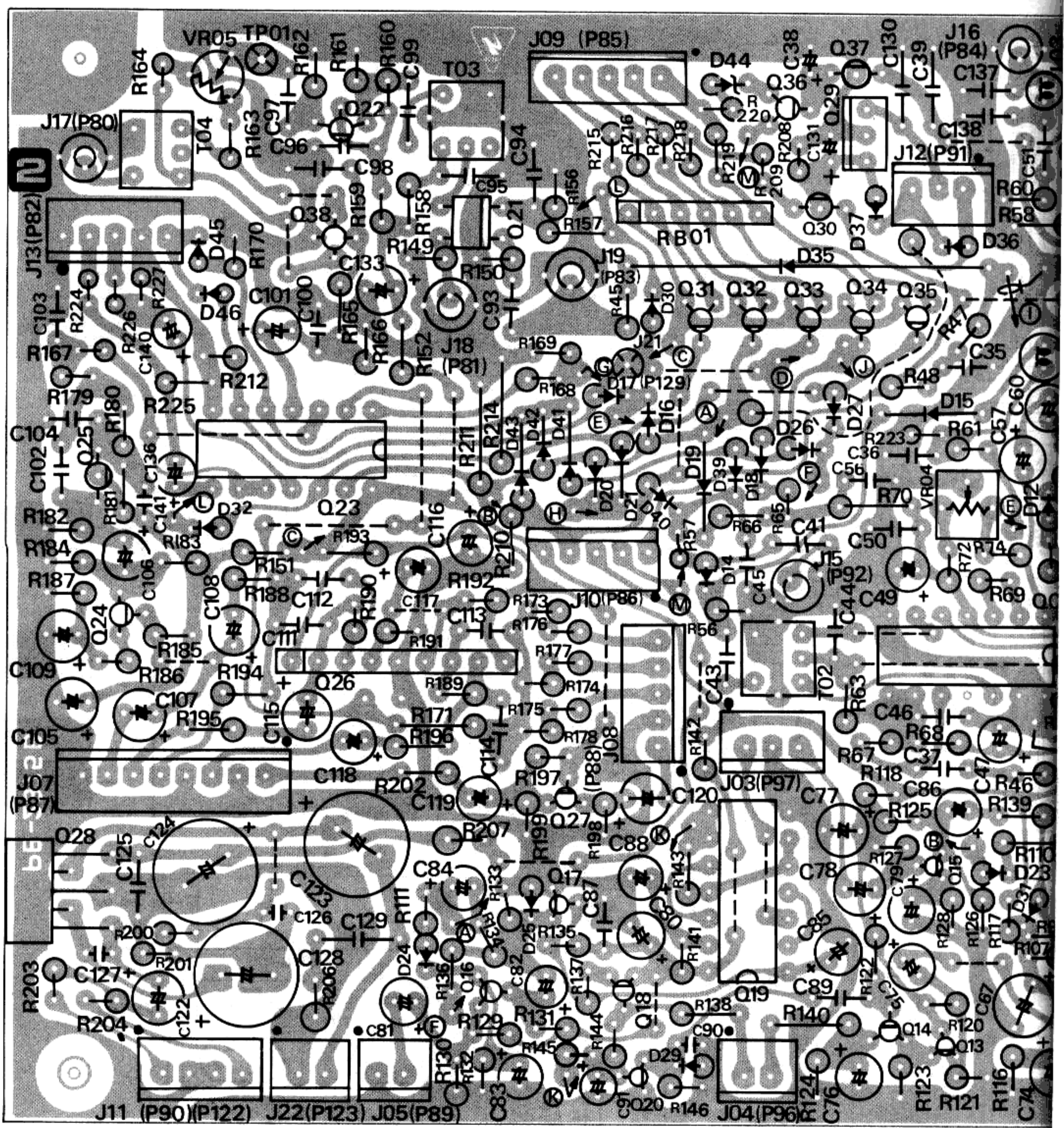

MC1496P
MC14011B
MC14066B

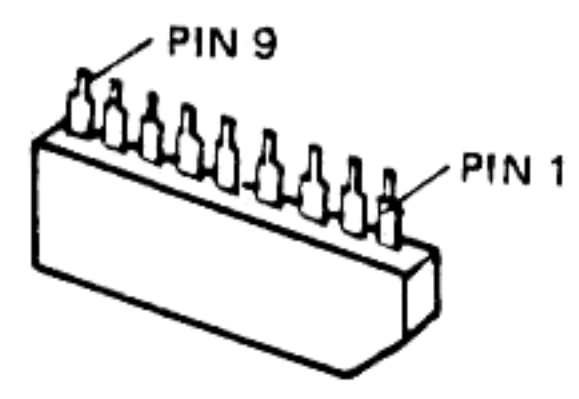

AN6551

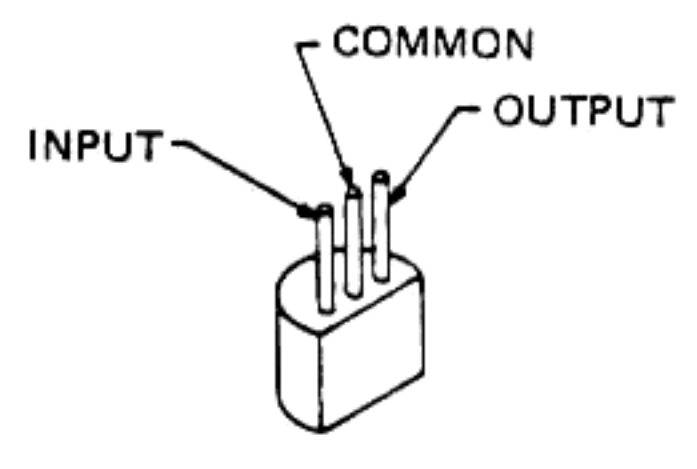

μPC78L05
NJM78L09A

BASE

PIN

AF UNIT PARTS LAYOUT (component side)

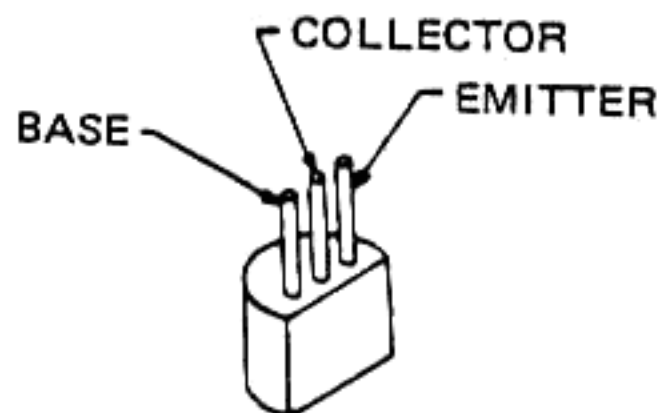
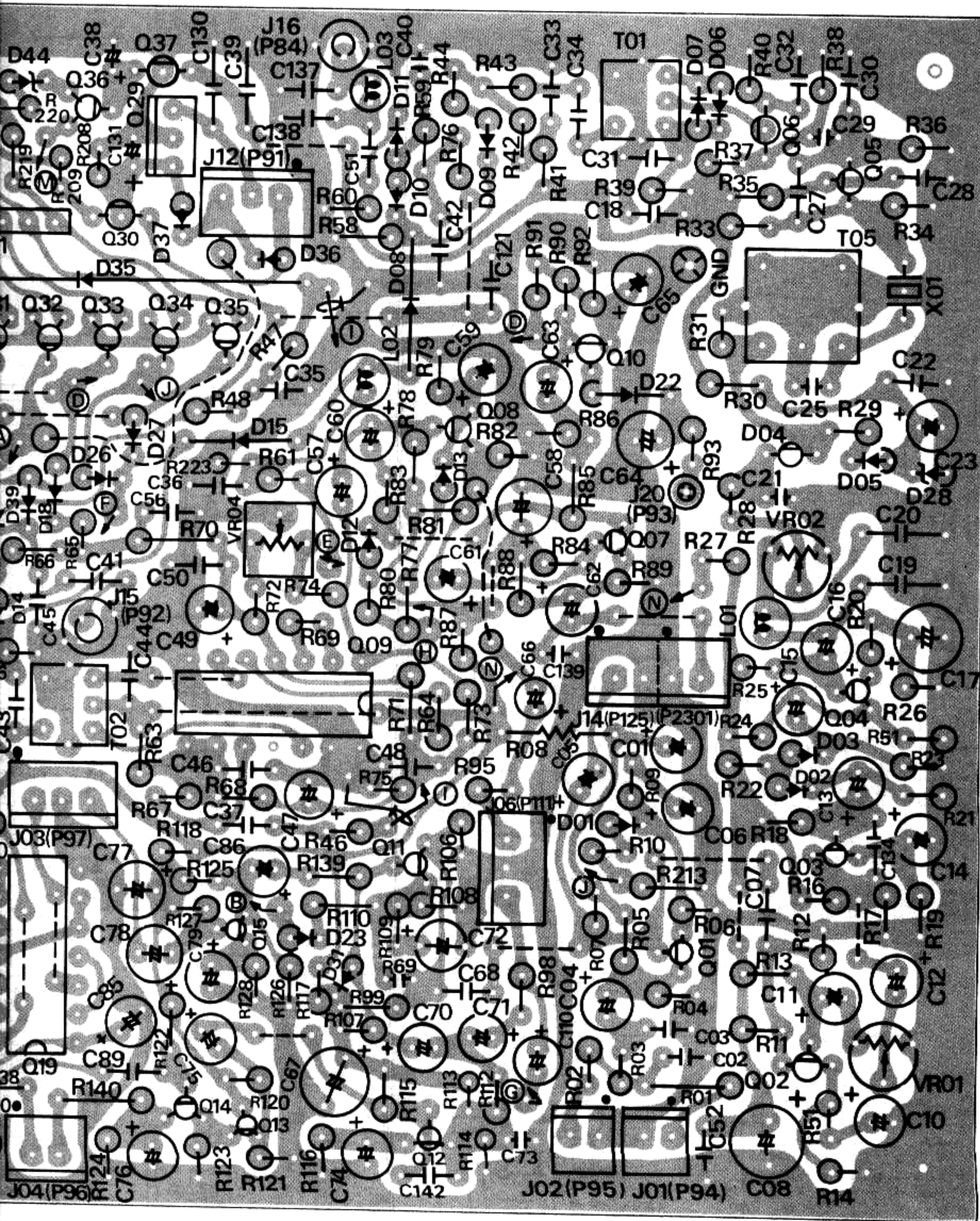

- 2SA564AR
- 2SA733P
- 2SA950Y
- 2SB774
- 2SC732GR
- 2SC945P
- 2SC1815Y
- 2SC1815GR

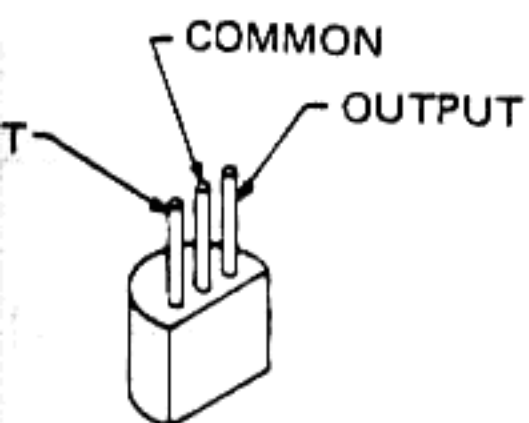

- μPC78L05
- NJM78L09A

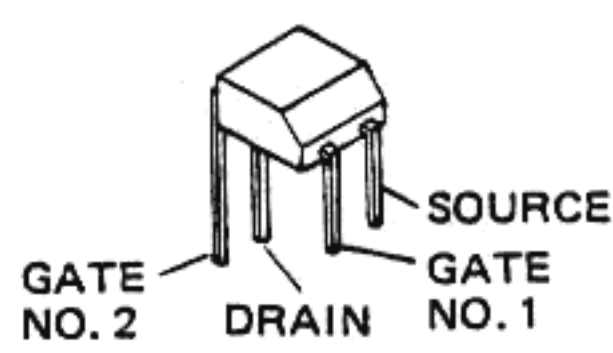
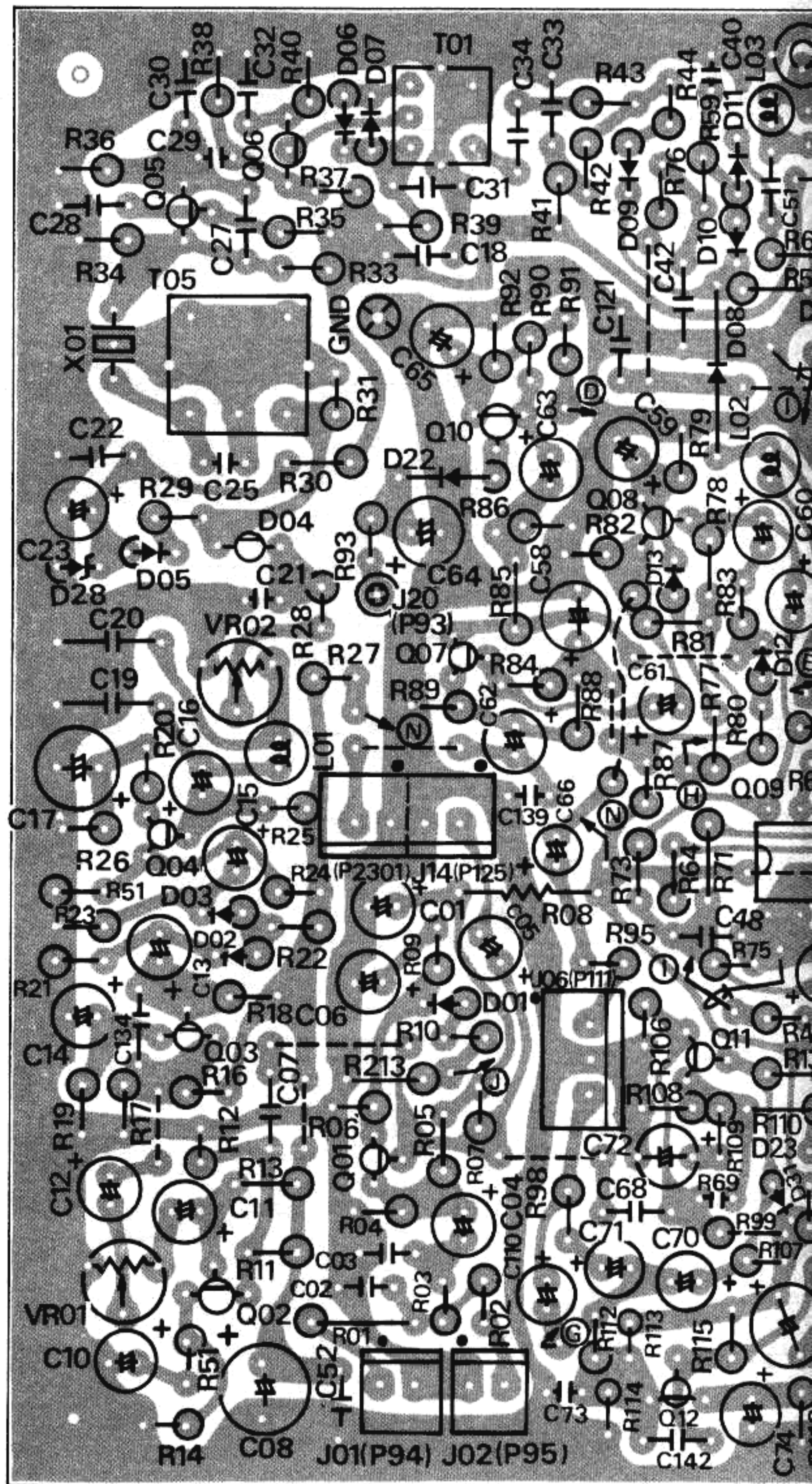

3SK73GR

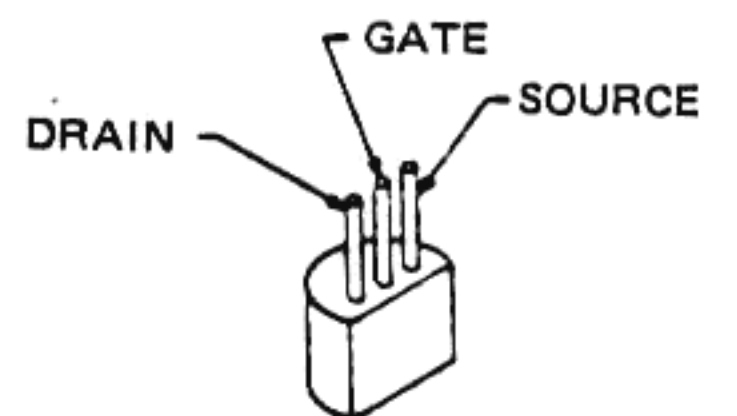

2SK107-3

AF UNIT PARTS LAYOUT (solder side)

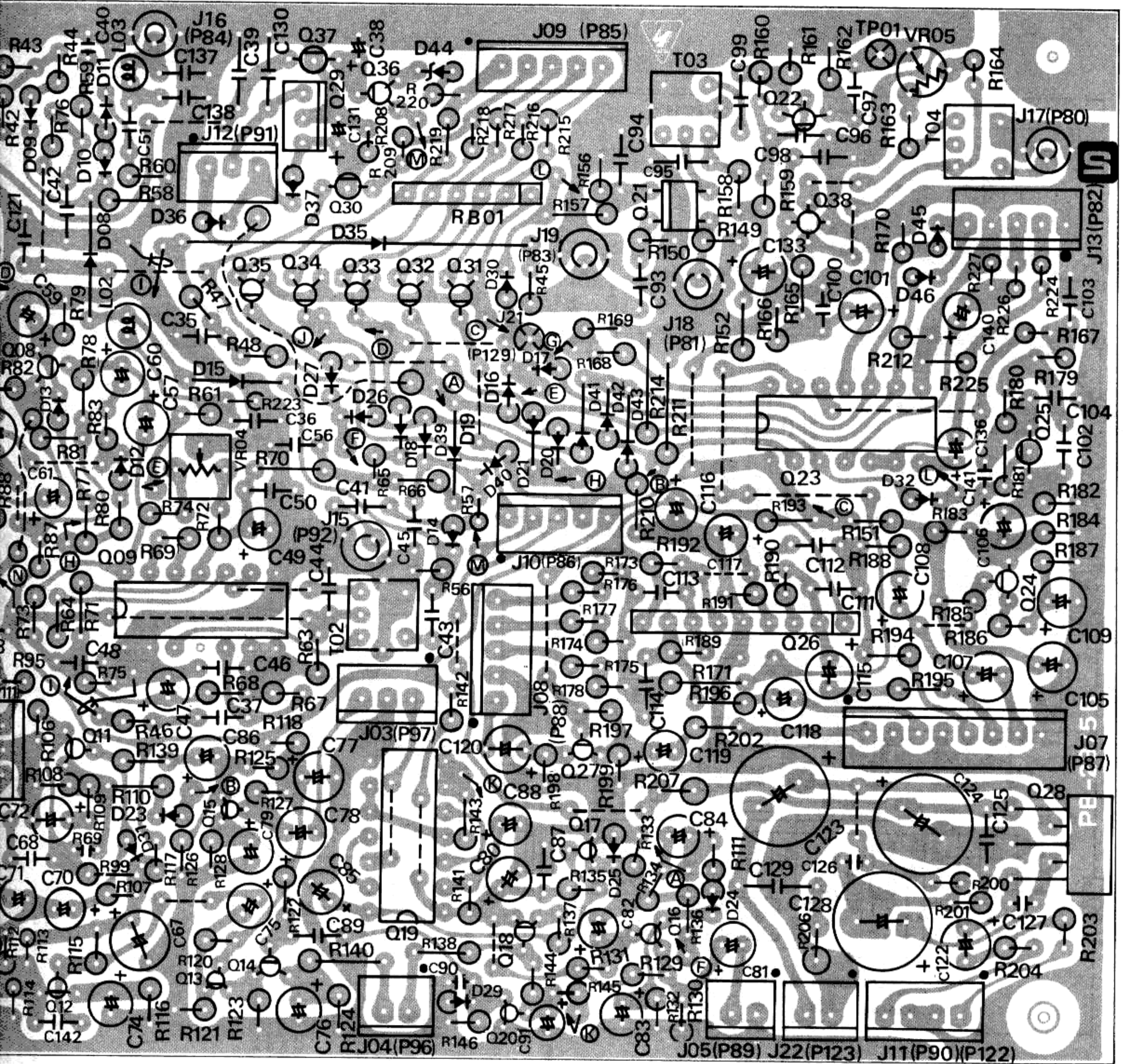

ATE SOURCE

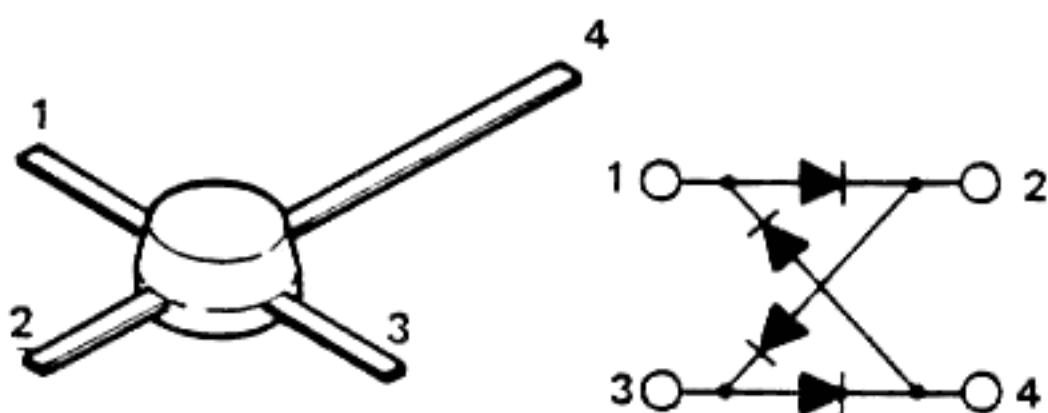

ND487R1-3R

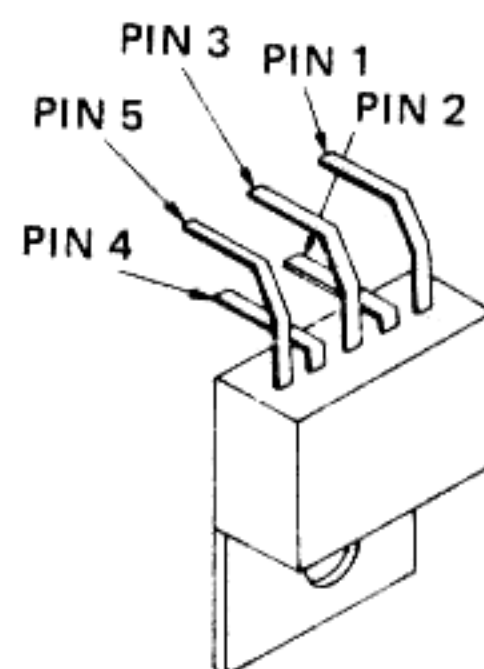

μPC2002V

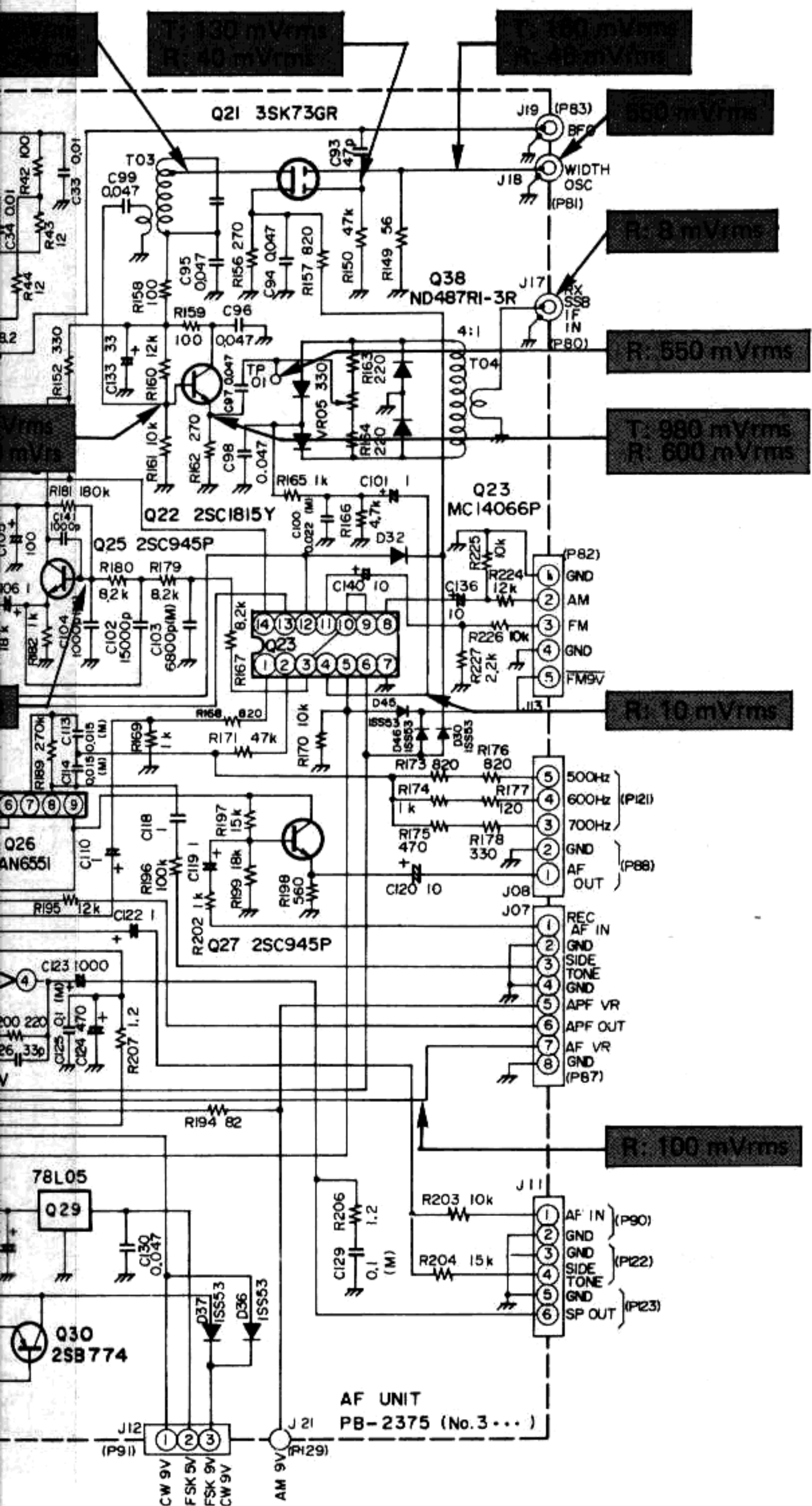

AF UNIT VOLTAGE CHART

(DC VOLTS)

	E (S)		C (D)		B (G1)		(G2)		REMARKS
	R	T	R	T	R	T	R	T	
Q3001	3.8		5		2.5				FSK
	5.5		9		2.6				
Q3002	1.5		3.1		2.1				
Q3003	1.3		5		2.1				
Q3004	1.2		3.9		1.8				
Q3005	0	-	0	8.6	0	-			FM
Q3006	0	1.7	0	-	0	-			FM
Q3007	1.4		5.3		2				CW, FM
	6.5		9		2.2				
Q3008	1.5		3		2				CW, FM
	4.4		9		2.2				
Q3010	4.4		4.4		0				AM
Q3011	1.2		4.6		1.8				CW
	4.5		7		2				
Q3012	1.2		4.3		1.7				SSB CW
	5.2		8.7		2.7				
Q3013	6.3		8.7		2.7				SSB CW
	5.2		6.4		5.8				
Q3014	6.2		6.2		6.5				SSB CW
	5.2		6.4		5.8				
Q3015	2.6		5.1		3.2				
Q3016	1		6.9		1.6				CW
	4		9		1.6				
Q3017	0		9		0				FM, FSK
	0		0		0.7				
Q3018	9		9		9				FM, FSK VOX DELAY VR → MIN
	8.8		8.8		8				
Q3020	0		9		0				FM, FSK VOX DELAY VR → MIN
	0		8.8		0				
Q3021	0.3		-		-				AM, FM
	2		-		-				
Q3022	-		5.8	5.4	-				
Q3024	1.1		3.6		1.7				
Q3025	4.1		6.9		4.7				
Q3027	3.7		8.5		4.3				
Q3029	IN 9		COM 0		OUT 5				
Q3031	9		9		8.4				SSB
Q3032	9		9		8.4				CW
Q3033	9		9		8.4				AM
Q3034	9		9		8.4				FSK
Q3035	9		9		8.4				FM
Q3036	0.4	13	0	13.5	0	0			FM
Q3037	IN 13		COM 0		OUT 5				FM TX

AF UNIT VOLTAGE CHART

(DC VOLTS)

	1	2	3	4	5	6	7	8	9	10	11	12	13	14	REMARKS
Q3009	3	-	-	3	1.1	9	-	5.8	-	5.8	-	-	-	0	
Q3019	9	0	9	0	9	9	0	8.4	8.4	0	9	0	8	9	
Q3023	-	-	-	-	8	0	0	-	-	-	-	0	-	9	
Q3026	8	-	-	4.4	0	4.4	-	-	8						
Q3028	-	-	0	-	13.5										

AF UNIT

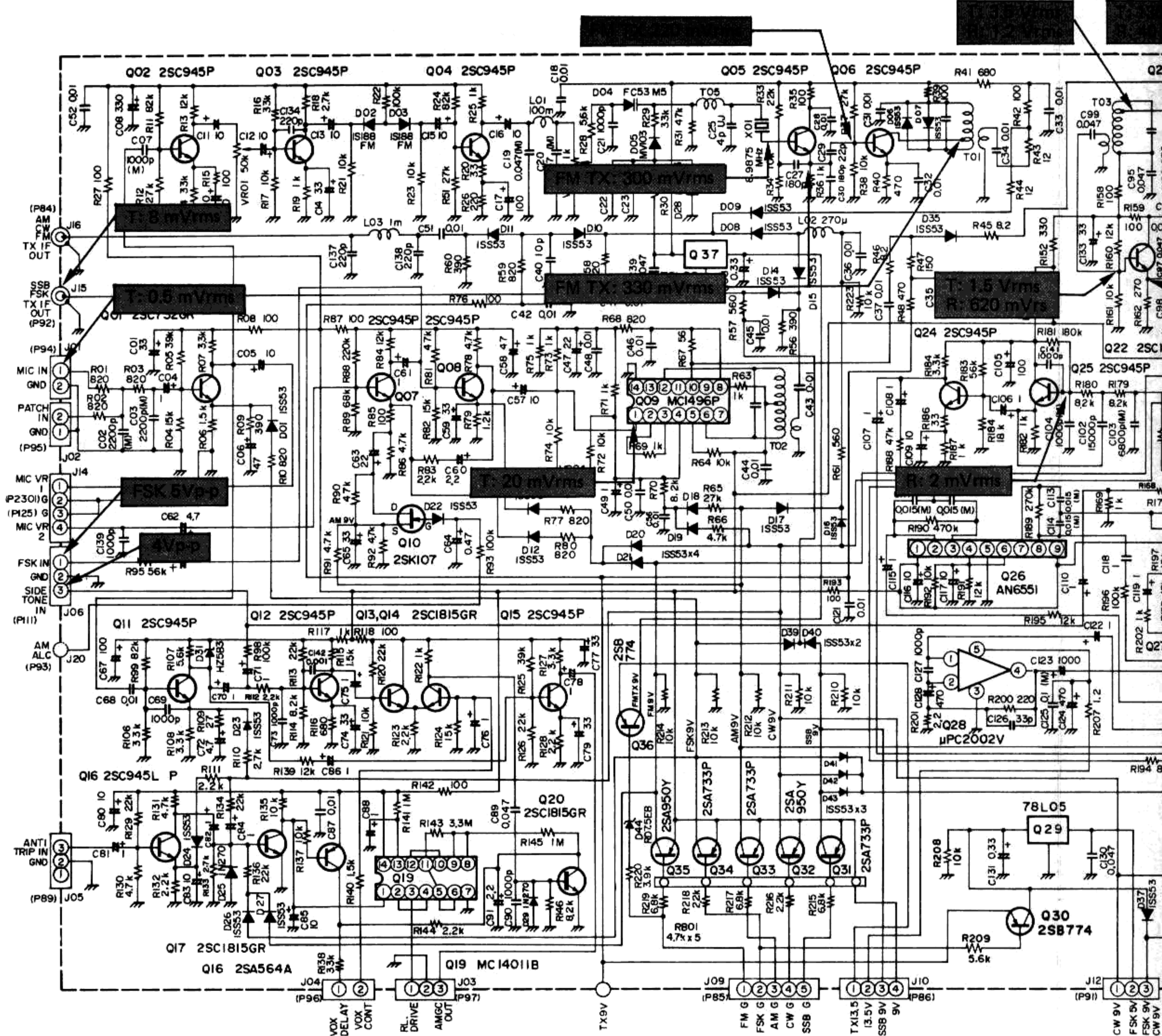

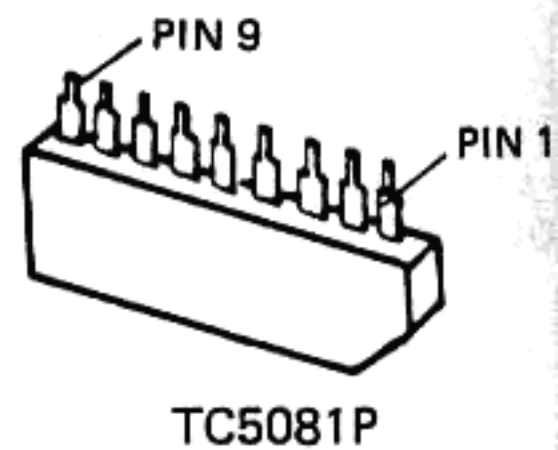
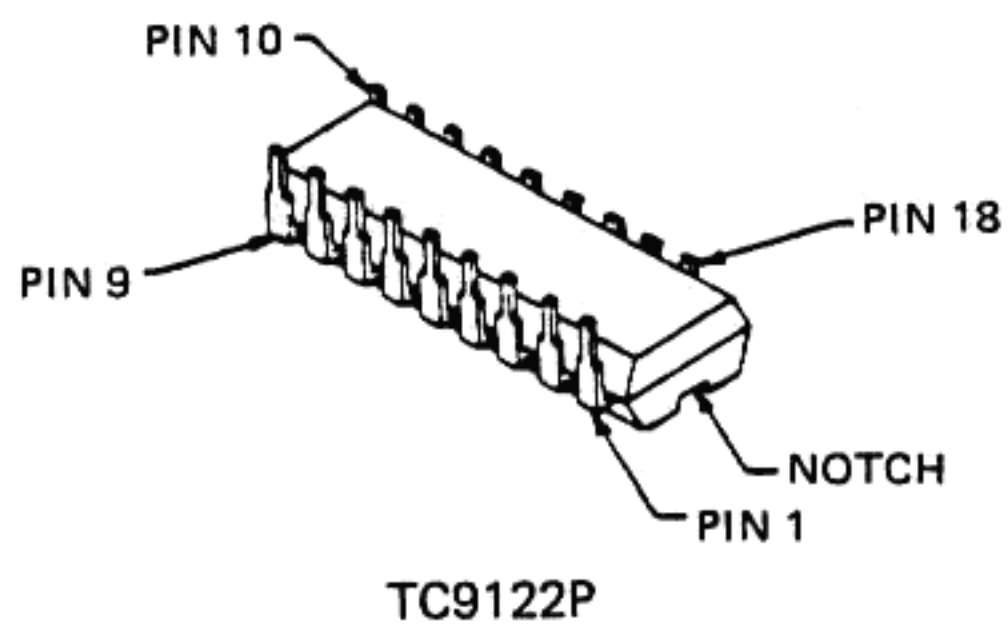
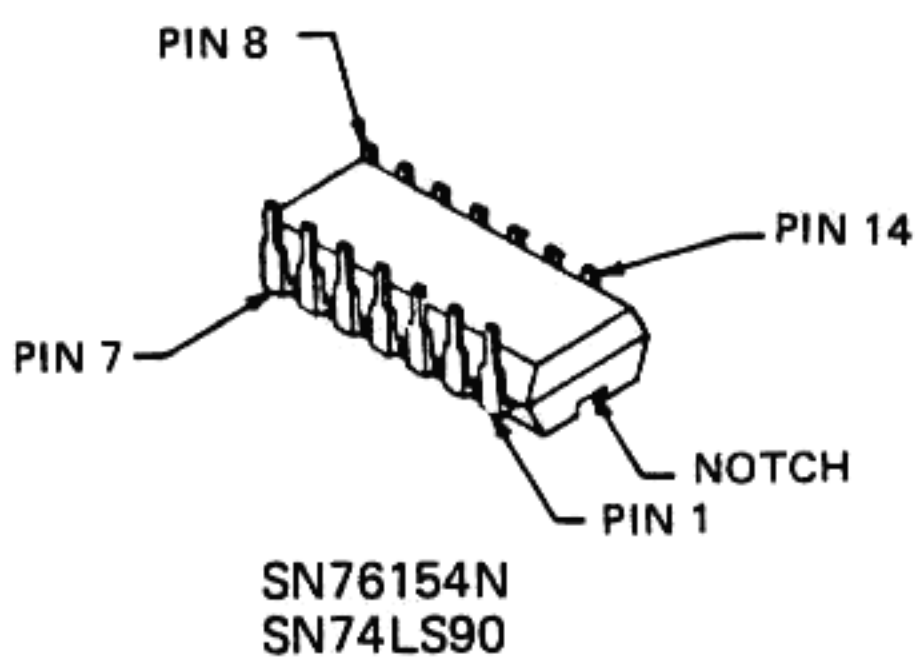
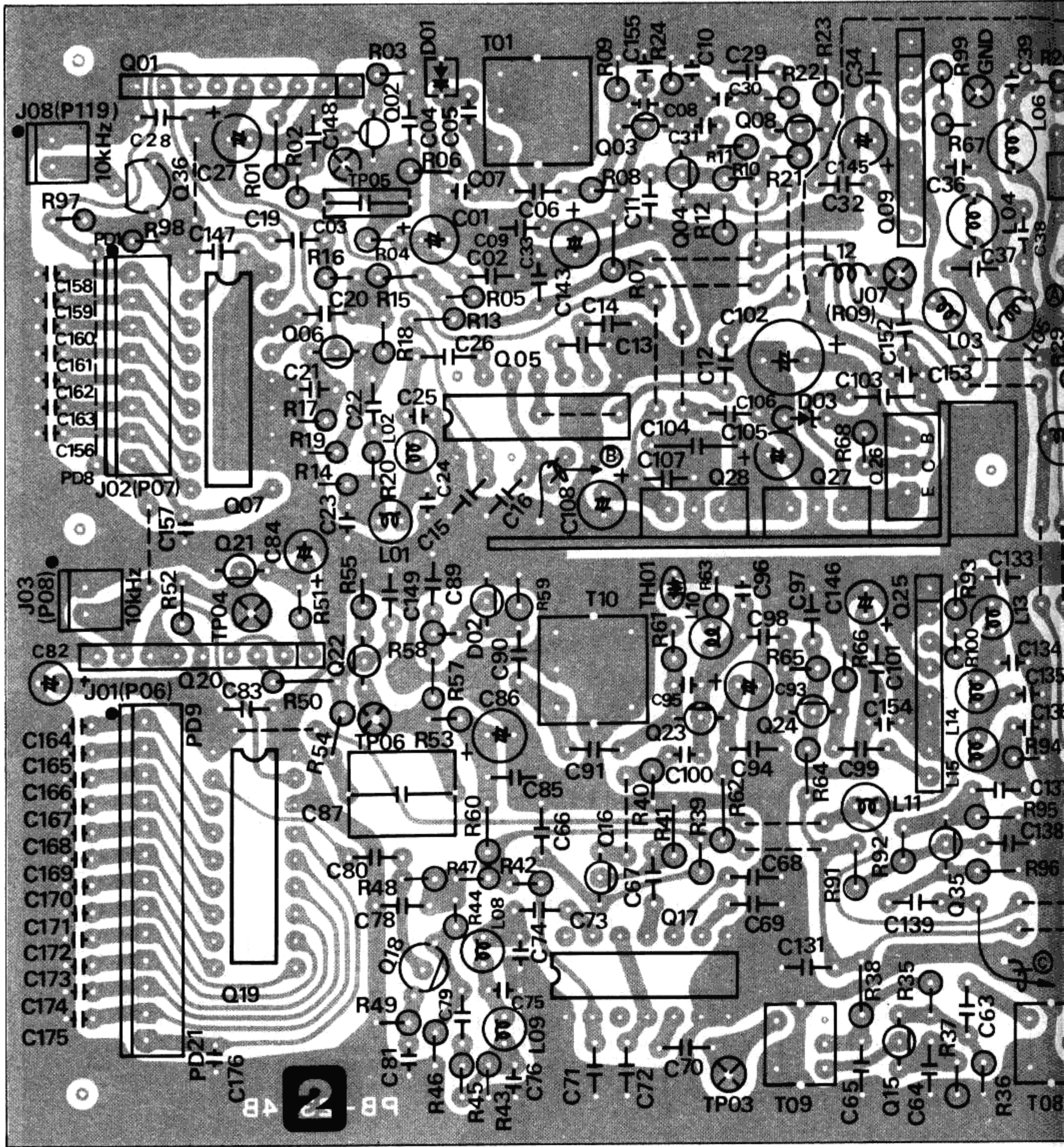

VFO UNIT PARTS LAYOUT (component side)

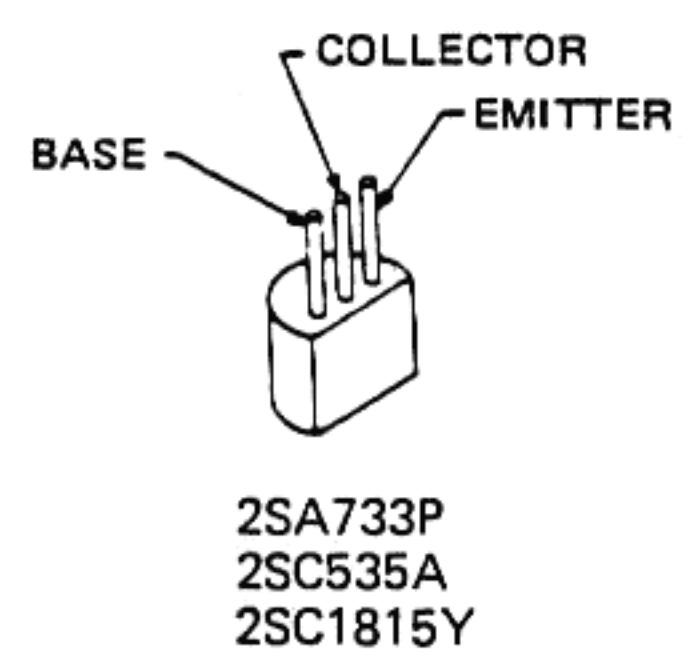
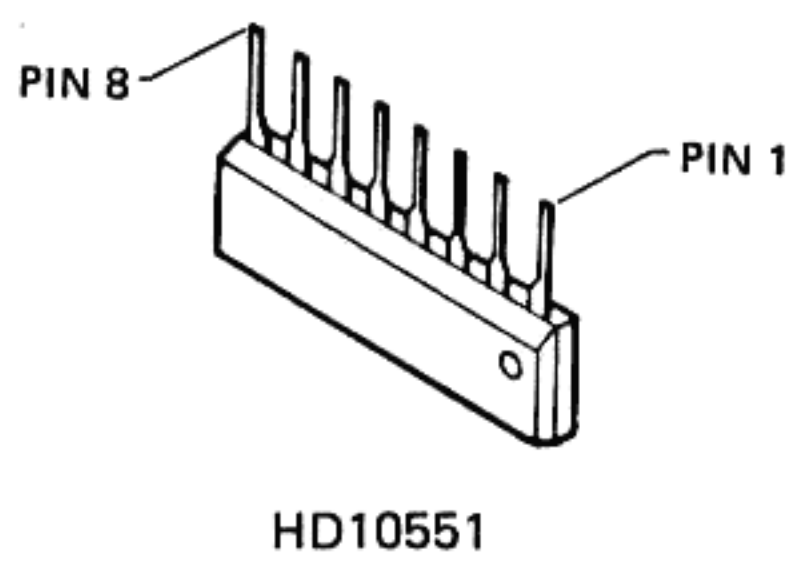
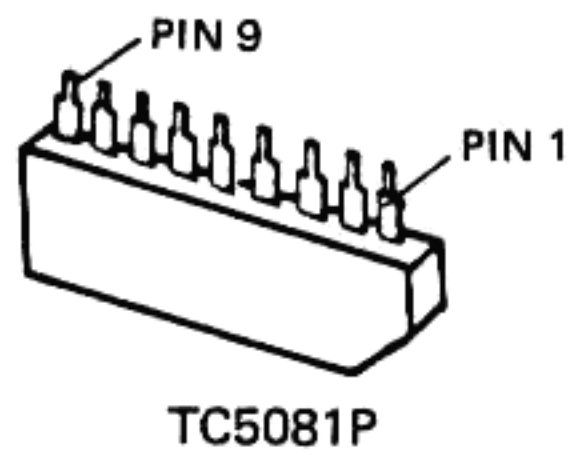
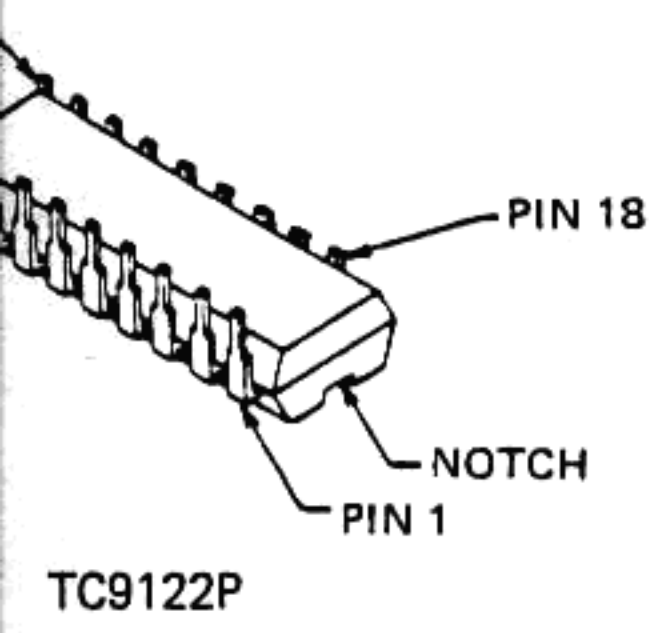
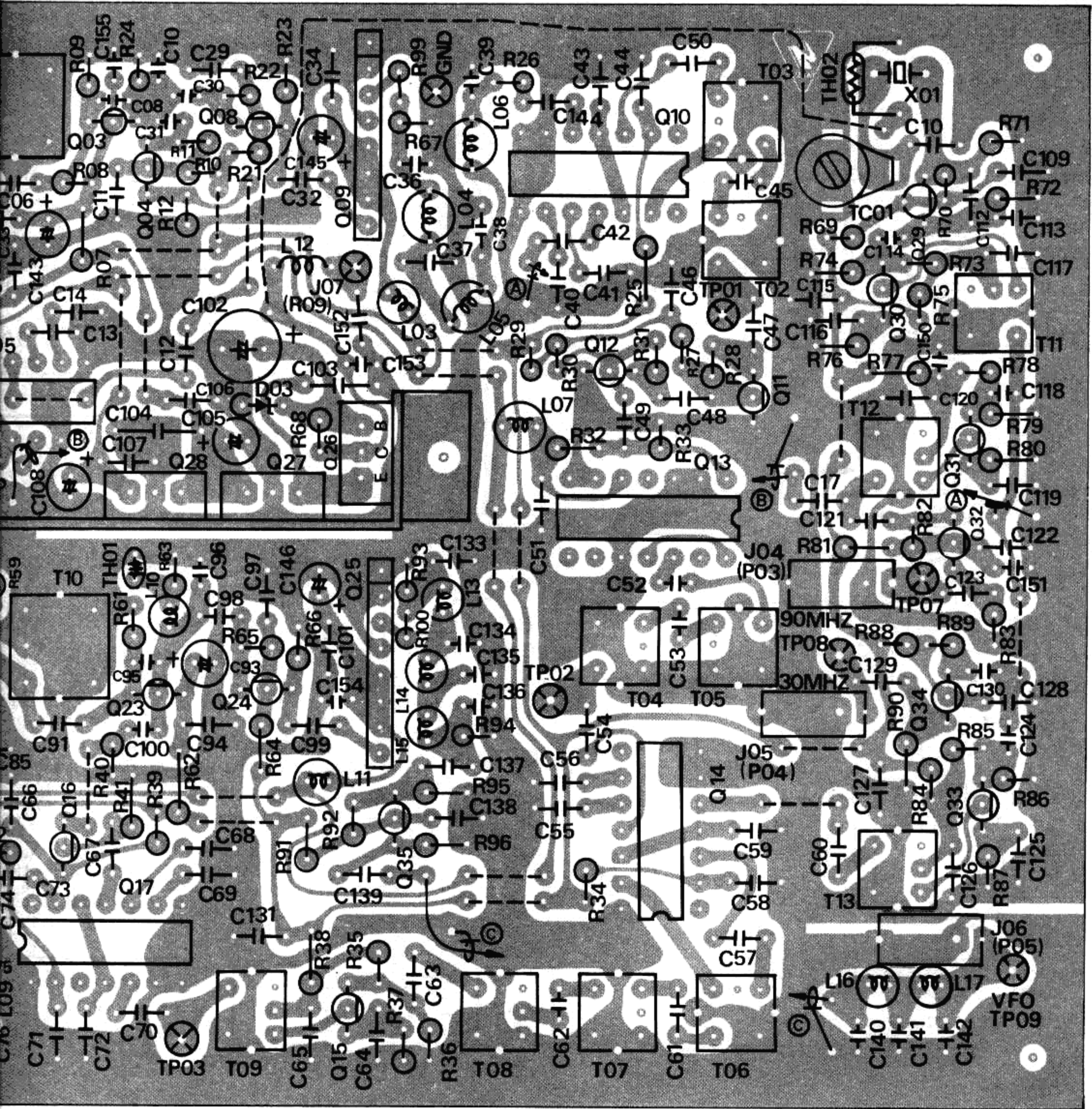

PARTS LAYOUT (solder side)

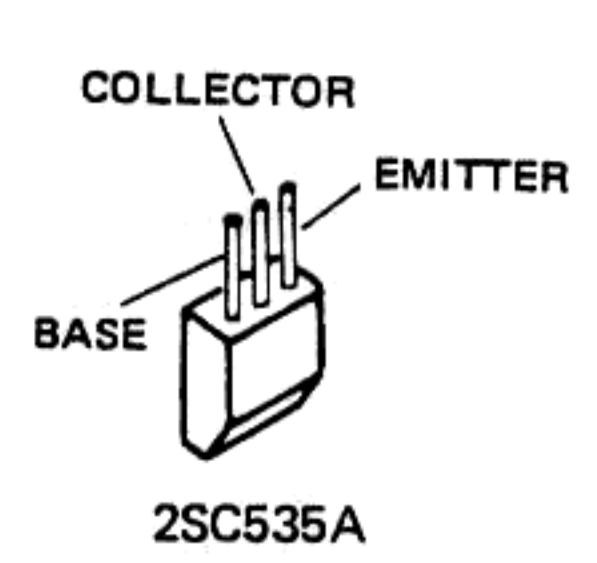
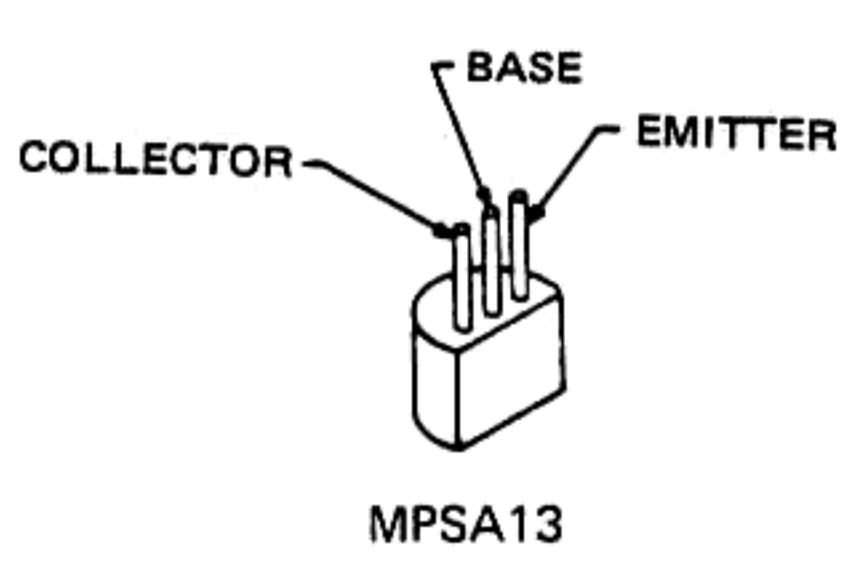
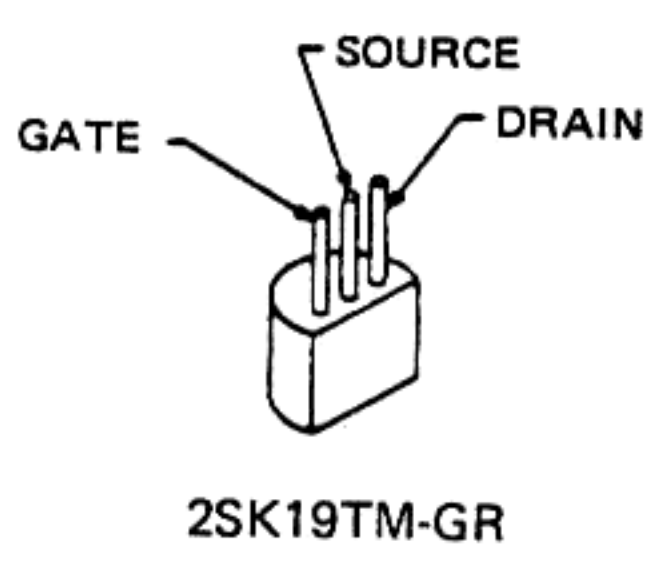
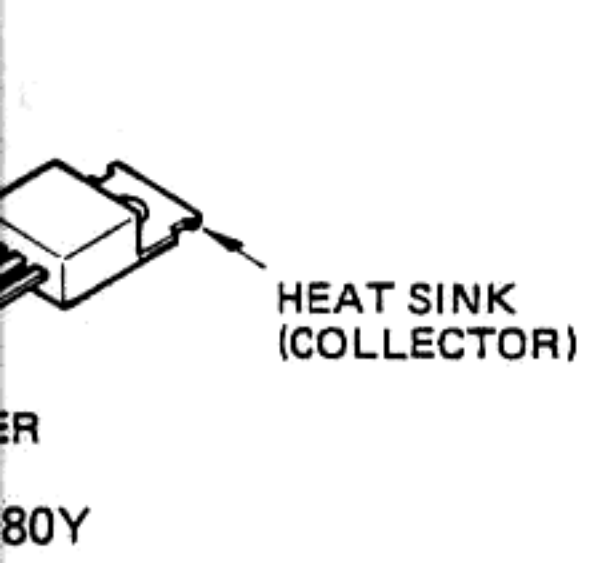
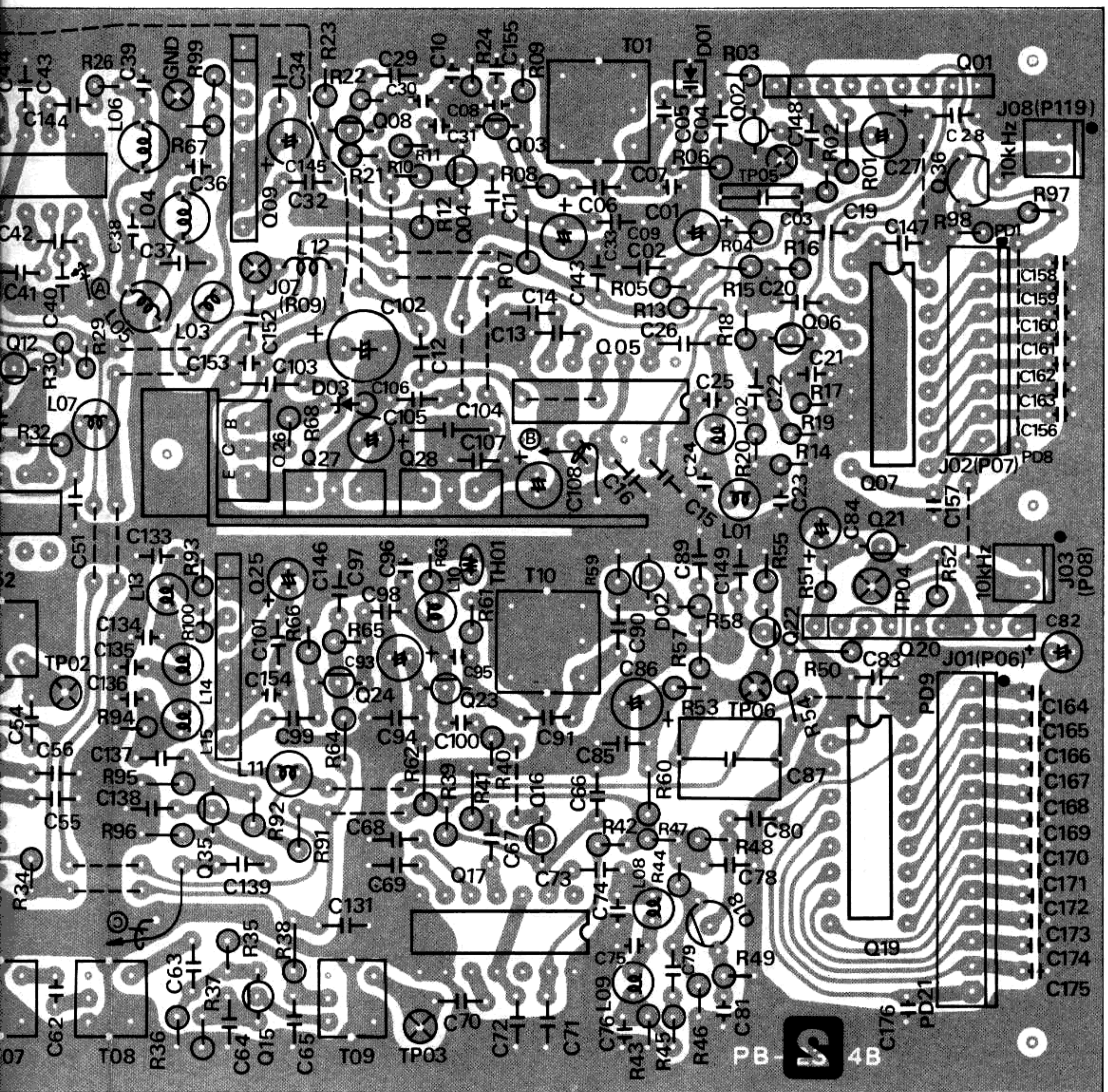

VFO UNIT PARTS LAYOUT (solder side)

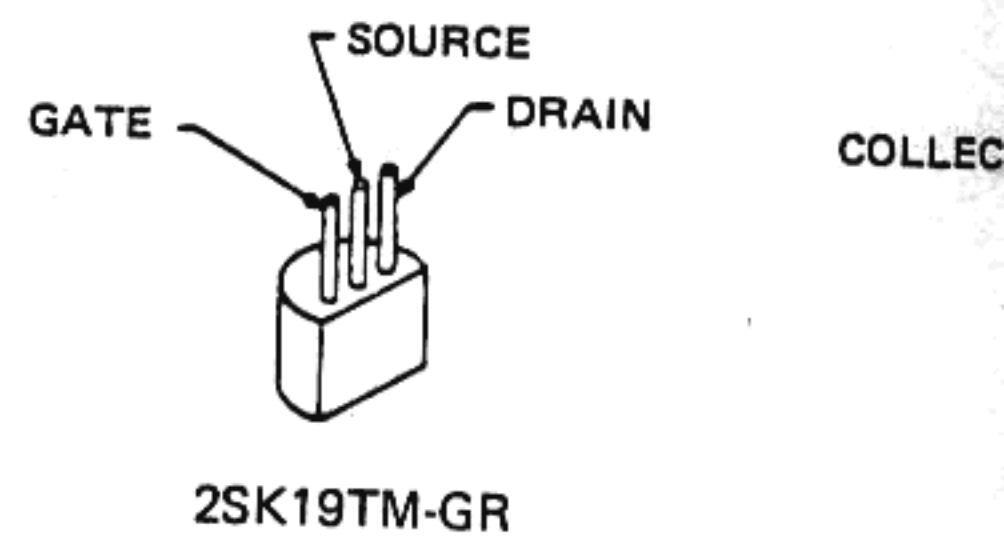
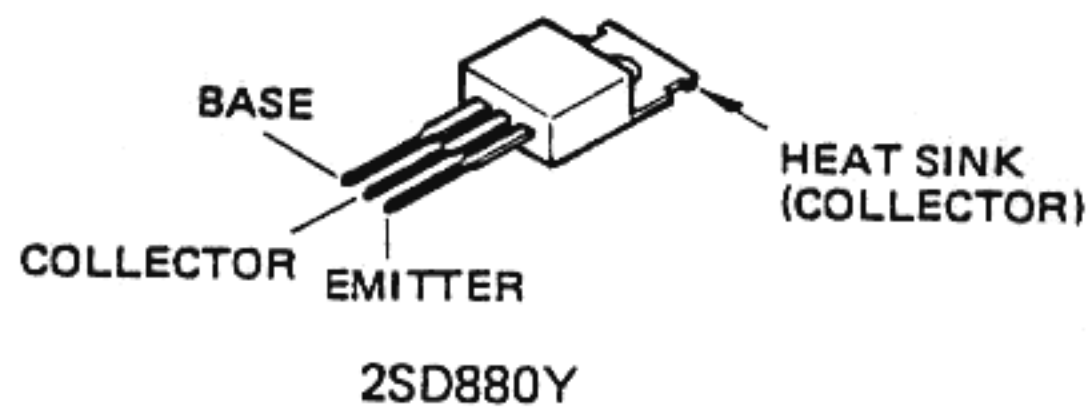
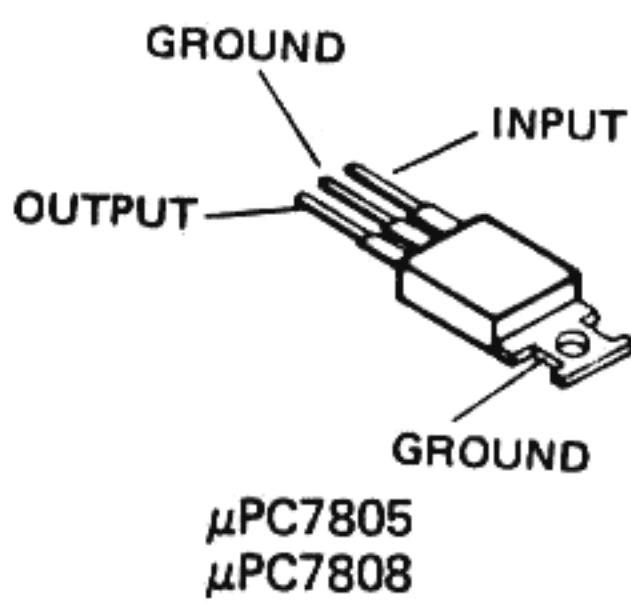
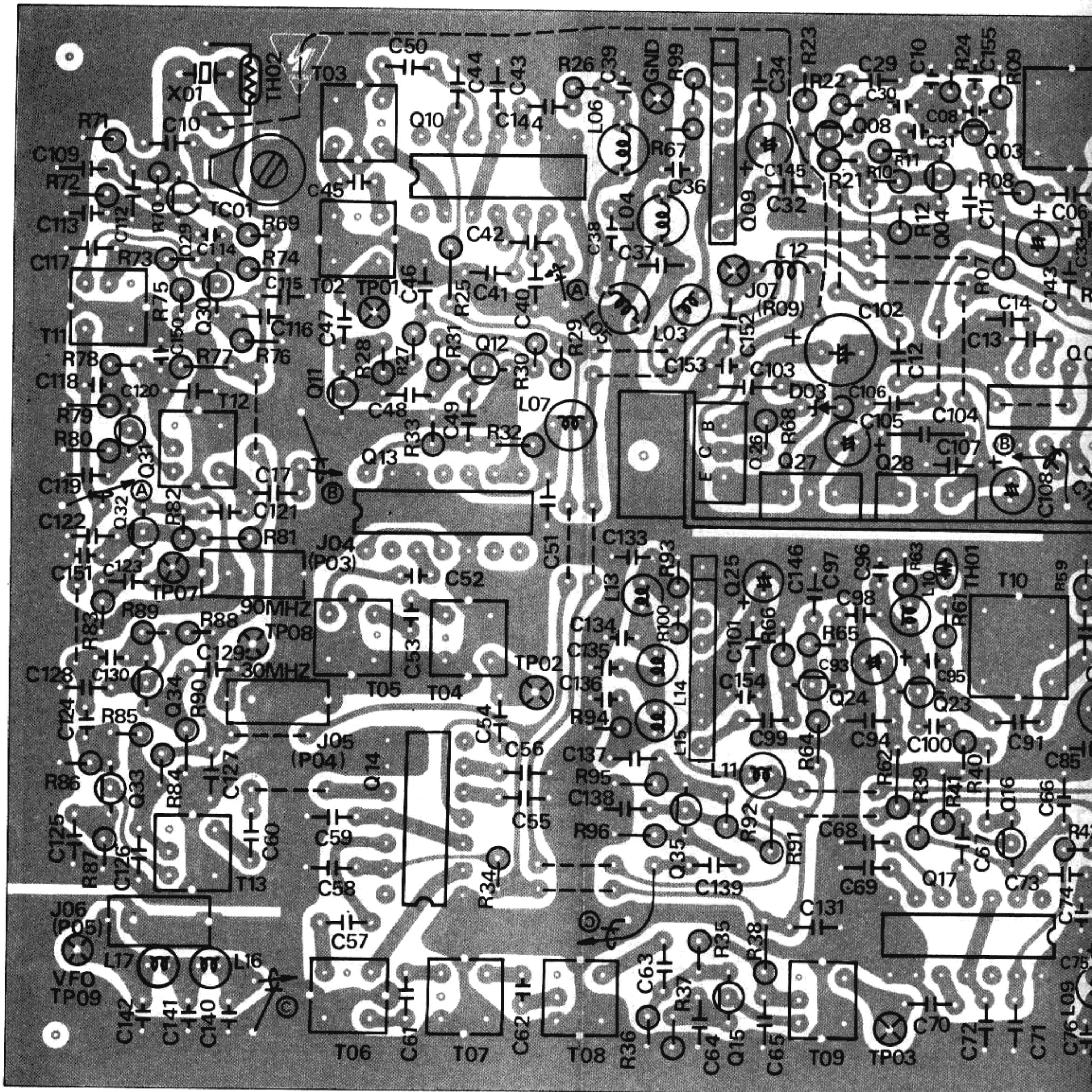

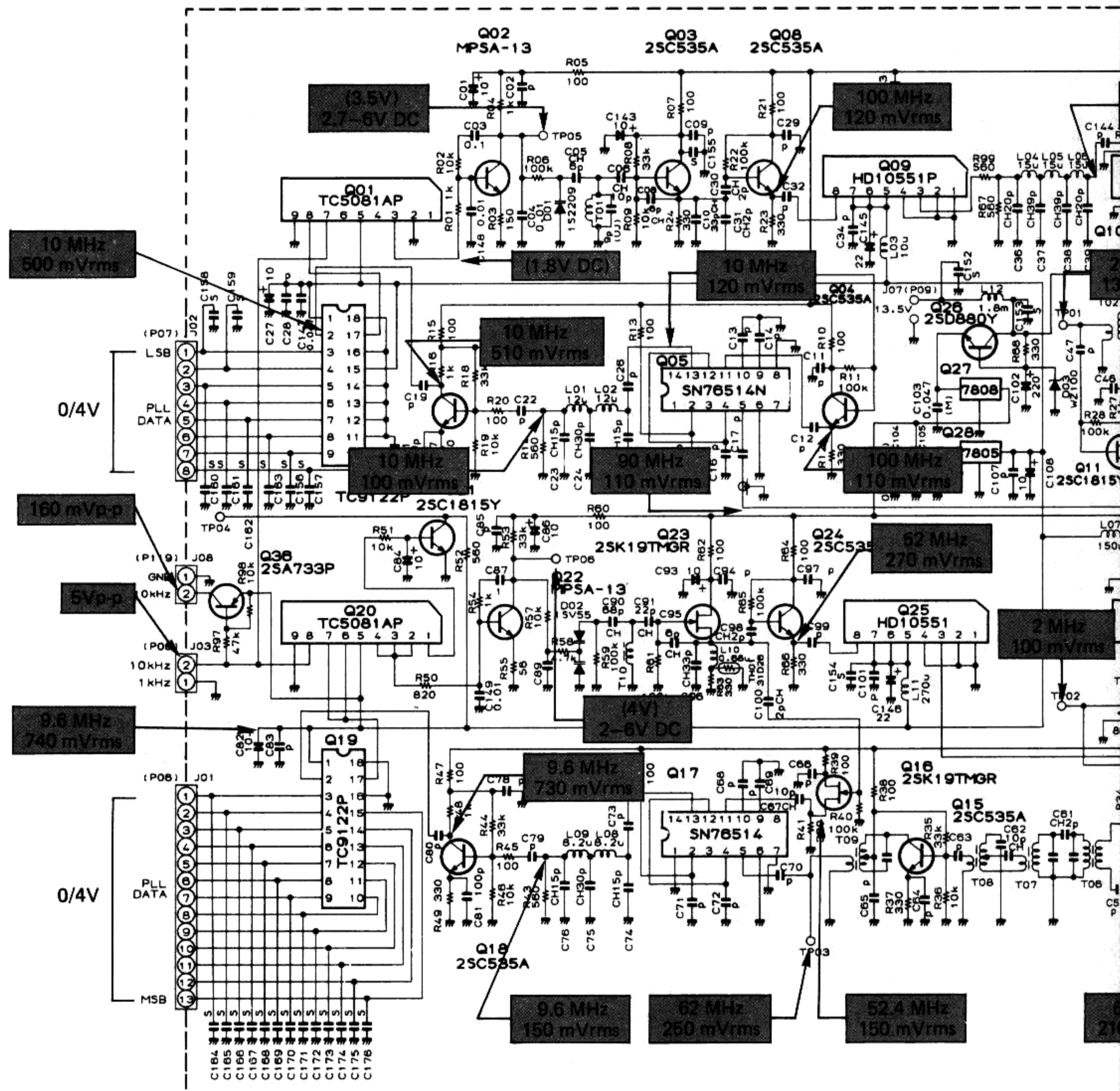

RESISTOR VALUES ARE IN OHMS, 1/4W. CAPACITOR VALUES ARE UF, 50V AND INDUCTOR VALUES ARE IN HENRIES, UNLESS OTHERWISE NOTED
 (p) CAPACITORS ARE 0.01UF, 50V
 (s) CAPACITORS ARE 0.001UF, 50V
 (*) CAPACITORS ARE INCLUDED IN TRANSFORMER CANS

() 14.25 MHz

VFO UNIT

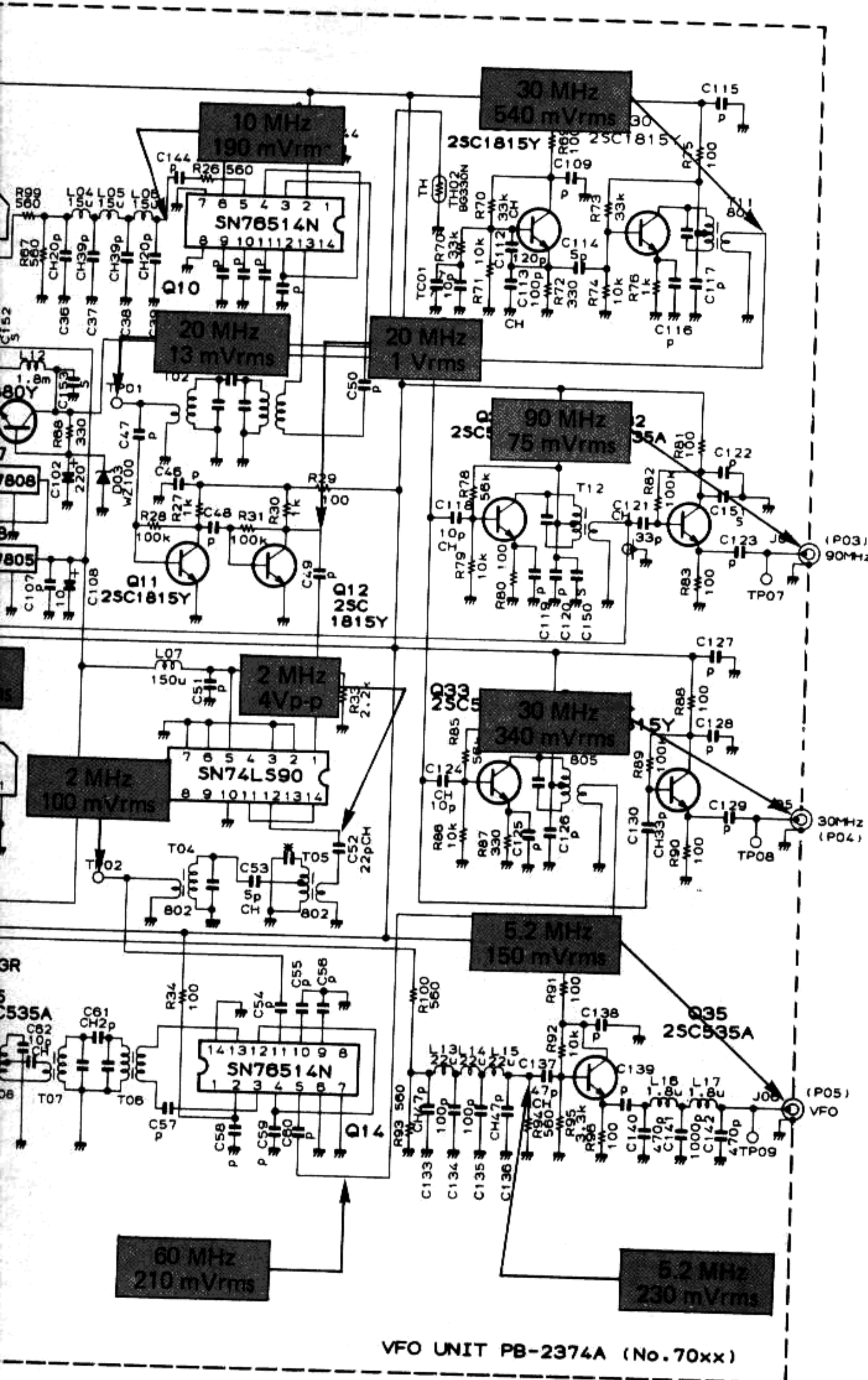

VFO UNIT PB-2374A (No. 70xx)

VFO UNIT VOLTAGE CHART

(DC VOLTS)

	E (S)		C (D)		B (G1)		(G2)		REMARKS
	R	T	R	T	R	T	R	T	
Q7002	0.3		6		1.5				
Q7003	1		7.8		1.7				
Q7004	1.4		7.8		2.2				
Q7006	0.8		5.5		1.7				
Q7008	1.4		7.8		2.2				
Q7011	0		3		6				
Q7012	0		3		6				
Q7015	0.8		8		1.5				
Q7016	1.4		7.8		0				
Q7018	1		5.5		1.7				
Q7021	0		5		0				
Q7022	0.3		2.3		1.5				
Q7023	1.1		7.6		0				
Q7024	0.7		7.8		2.1				
Q7026	9.7		13.5		10.3				
Q7027	IN 9.7		COM 0		OUT 8				
Q7028	IN 8		COM 0		OUT 5				
Q7029	1.5		7.7		1.5				
Q7030	1.2		8.1		1.8				
Q7031	0.3		8		0.8				
Q7032	0.5		7.7		1.2				
Q7033	0.5		8		1.1				
Q7034	1.1		7.1		1.7				
Q7035	0.7		7.3		0				

VFO UNIT VOLTAGE CHART

(DC VOLTS)

	1	2	3	4	5	6	7	8	9	10	11	12	13	14	15	16	17	18	REMARKS	
	Q7001	-	0	-	-	5	-	-	-	0										
Q7005	-	7.8	-	-	0	-	-	-	-	-	-	-	-	-	-	-	-	-	-	
Q7007	5	-	-	-	-	-	-	-	-	0	0	0	0	0	5	0	-	0		
Q7009	0	0	-	0	5	5	5	-	-	-	-	-	-	-	-	-	-	-		
Q7010	-	7.8	-	-	0	-	-	-	-	-	-	-	-	-	-	-	-	-		
Q7013	-	0	0	-	5	0	0	-	-	0	-	-	-	-	-	-	-	-		
Q7014	-	7.8	-	-	0	-	-	-	-	-	-	-	-	-	-	-	-	-		
Q7017	-	7.8	-	-	0	-	-	-	-	-	-	-	-	-	-	-	-	-		
Q7019	5	-	-	-	-	-	-	-	-	-	-	-	-	-	-	-	-	-		
Q7020	-	-	-	-	5	-	-	-	0	-	-	-	-	-	-	0	-	0		
Q7025	0	0	-	0	5	5	5	-	-	-	-	-	-	-	-	-	-	-		

UNIT PARTS LAYOUT (component side)

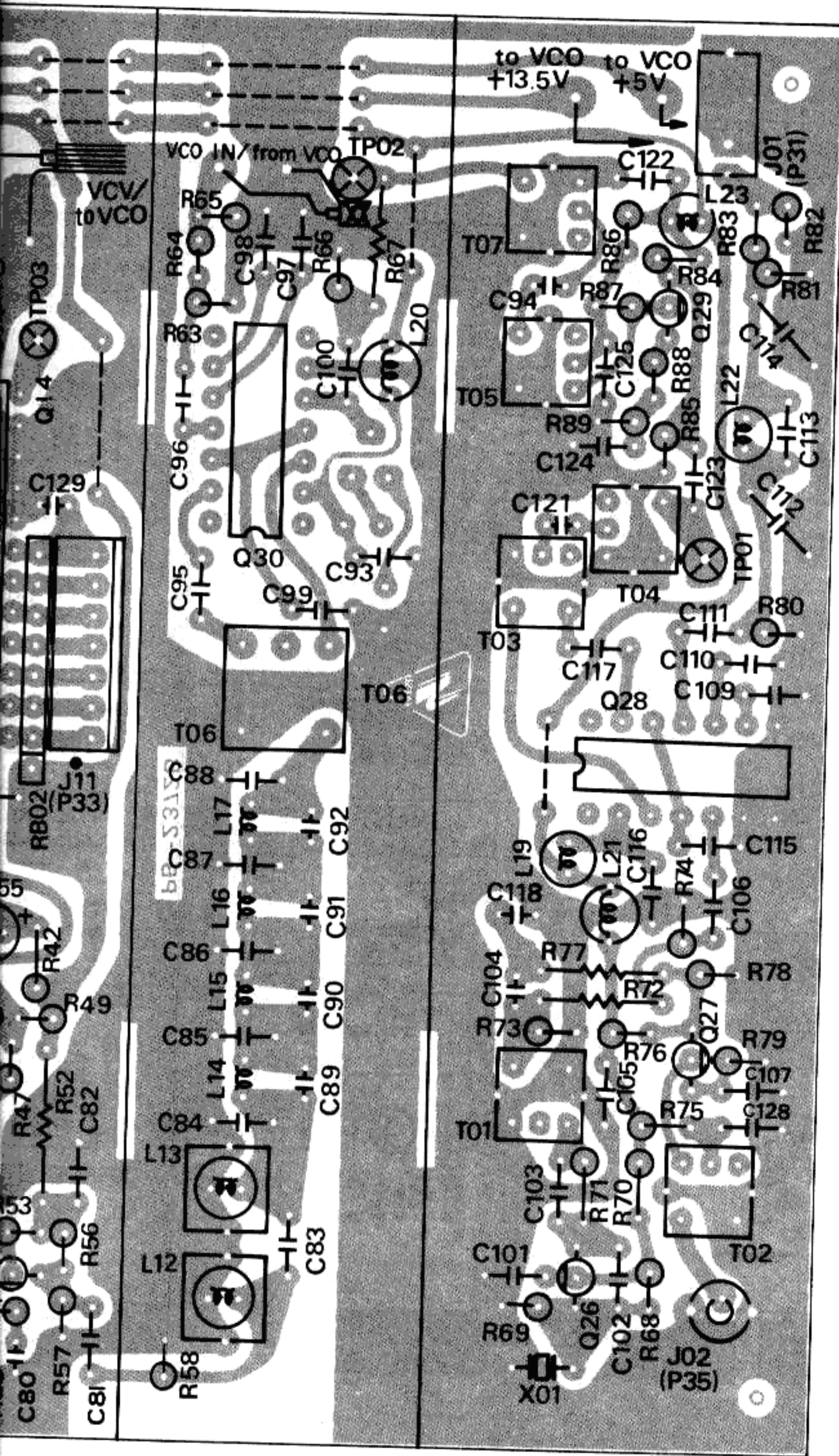

PLL UNIT VOLTAGE CHART

(DC VOLTS)

	E (S)		C (D)		B (G1)		(G2)		REMARKS
	R	T	R	T	R	T	R	T	
Q4001	0.4		4.8		1.6				USB 14.25 MHz IF SHIFT → CEN
Q4002	1.3		8.2		0				
Q4003	1		9		1.7				
Q4004	IN 13.5		COM 0		OUT 9				USB JF SHIFT → CEN
Q4005	1		9		1.7				
Q4008	0		0		0.6				
Q4009	0.4		8.8		0		4.1		
Q4010	IN 13.5		COM 0		OUT 5				
Q4024	1.9		4.3		2.6				
Q4026	2.6		9.2		2.7				
Q4027	1.5		8.8		2.3				
Q4029	1.3		9		2				
Q4031	0		13.5		0				

PLL UNIT VOLTAGE CHART

(DC VOLTS)

	1	2	3	4	5	6	7	8	9	10	11	12	13	14	15	16	REMARKS
Q4006	0	0	-	0	5	5	5	-									
Q4013	-	9	-	-	-	0	-	-	-	-	-	-	-	-	-	-	
Q4015	-	5	-	-	-	0	0	-	5	-	-	-	-	-	0	5	
Q4016	-	-	-	0	5	5	-	0	0	5	5	0	0	-	-	-	
Q4018	-	0	0	-	5	0	0	-	0	-	-	-	-	-	-	-	
Q4019	-	-	-	-	5	0	0	-	0	-	-	-	-	-	-	-	
Q4020	-	0	0	-	5	0	0	-	0	-	-	-	-	-	-	-	
Q4022	0	0	-	0	5	5	5	-									
Q4028	-	9	-	-	-	0	-	-	-	-	-	-	-	-	-	-	
Q4030	-	0	-	-	-	0	-	-	-	-	-	-	-	-	-	-	

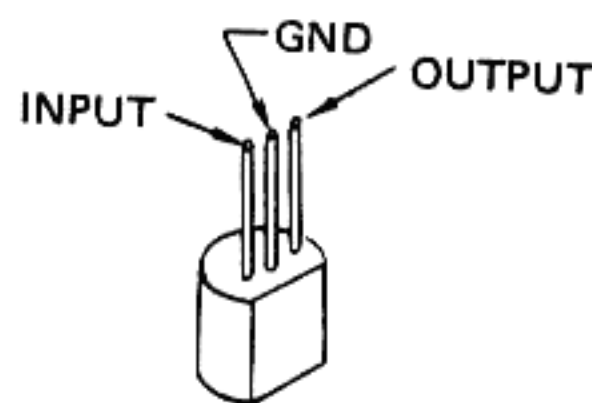
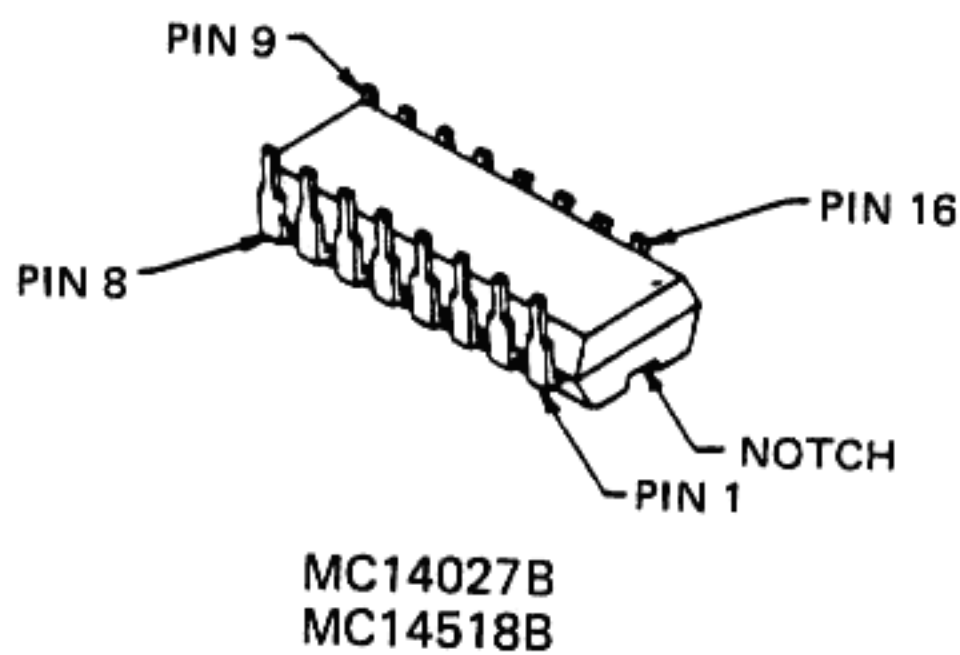

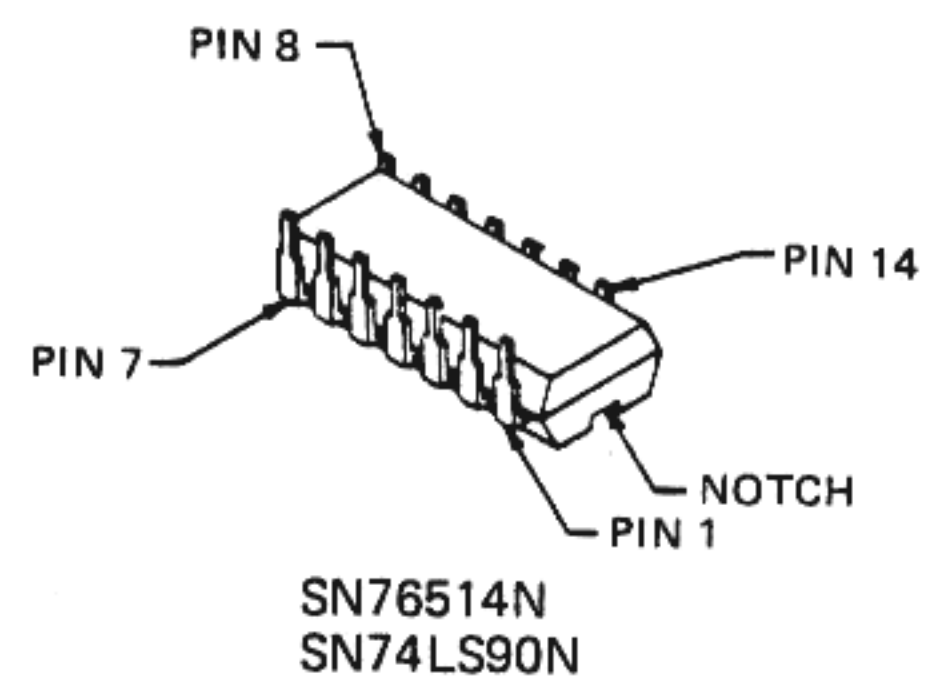
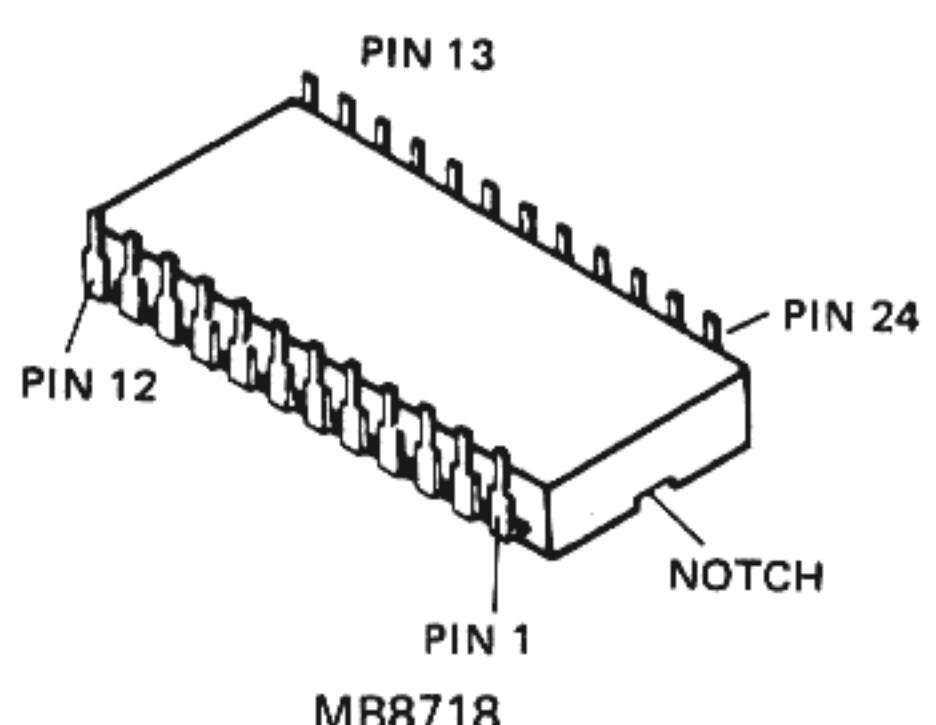
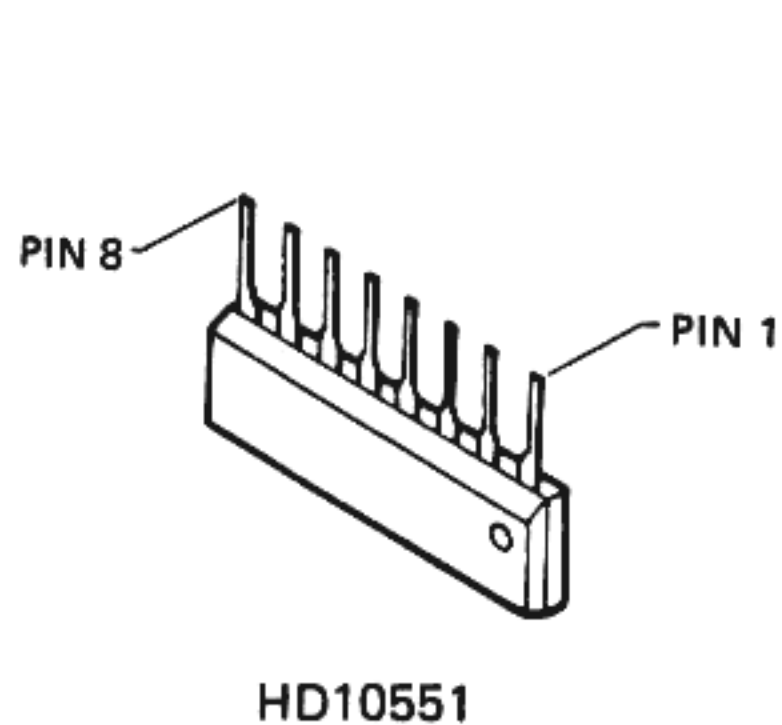
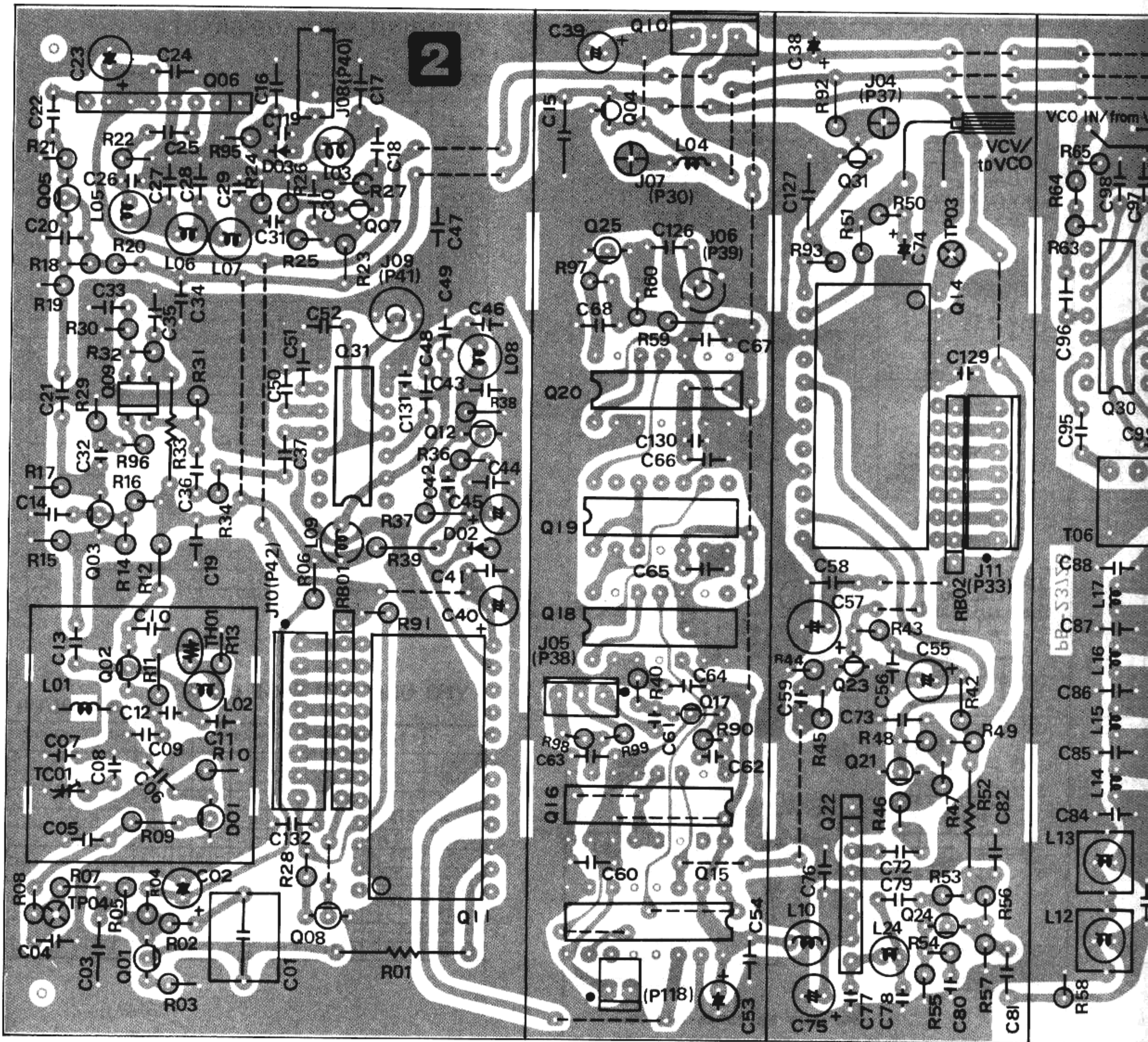

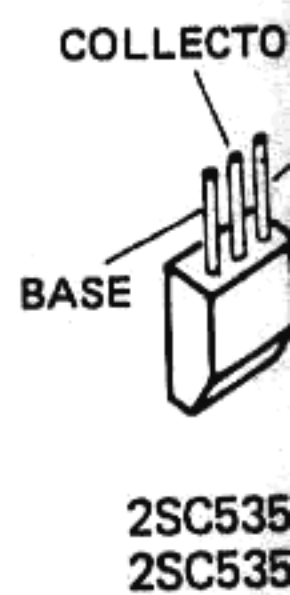
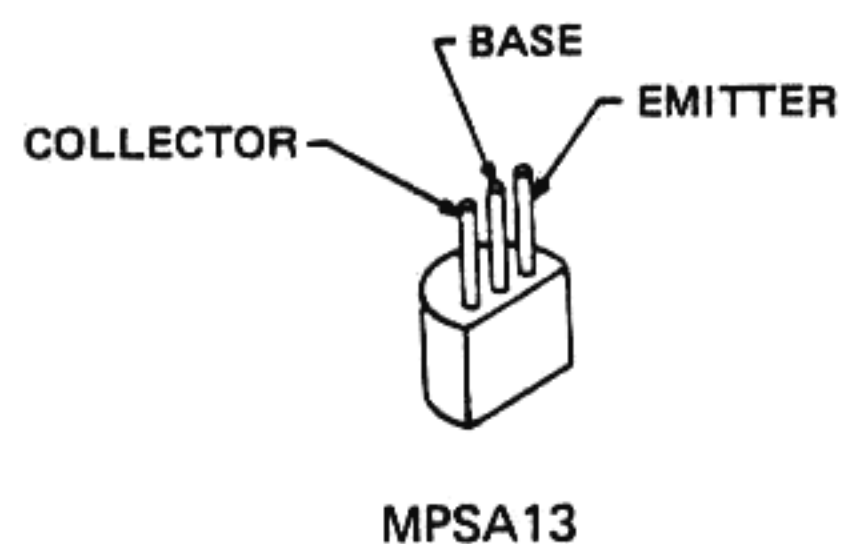
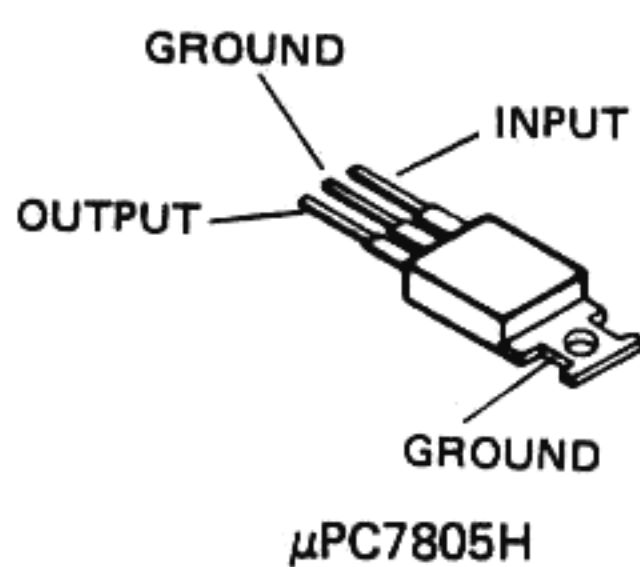
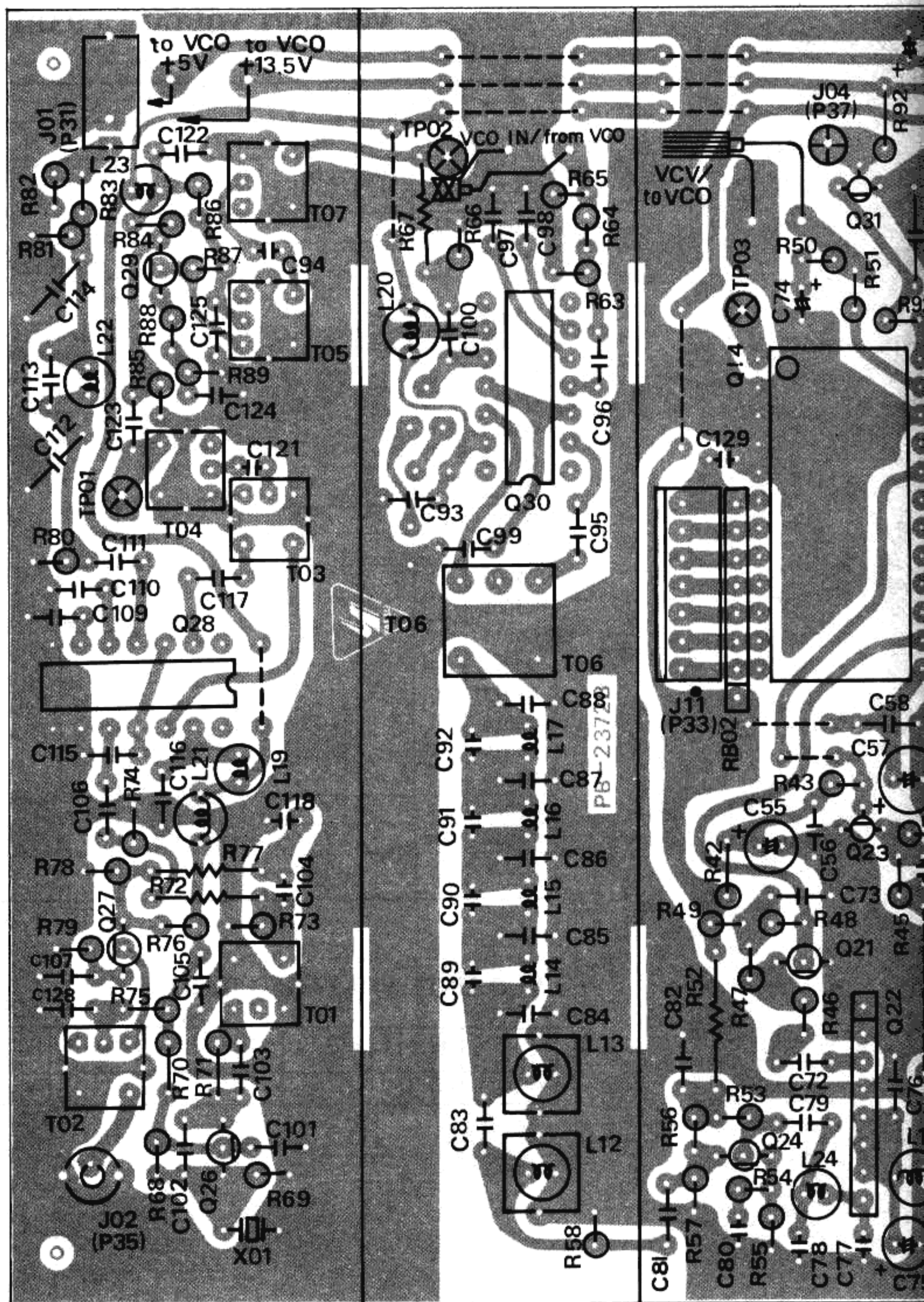

PLL UNIT PARTS LAYOUT (solder side)

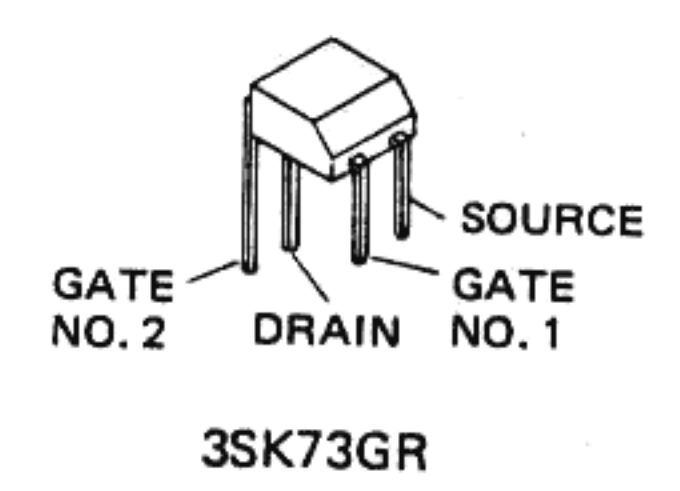
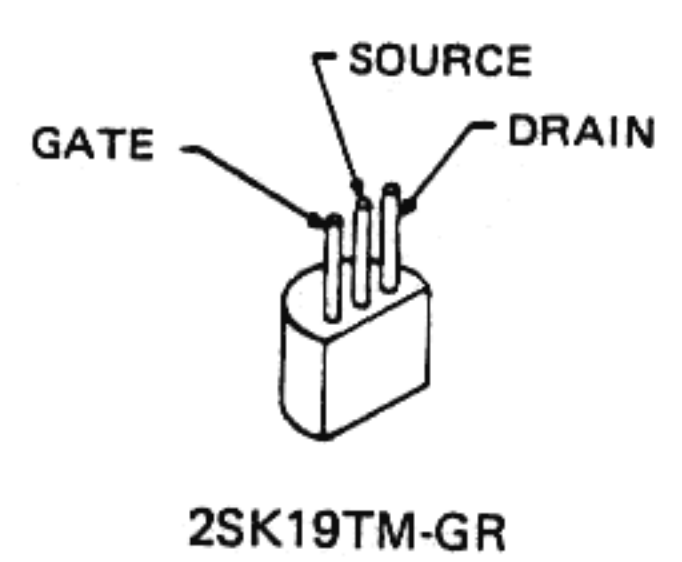
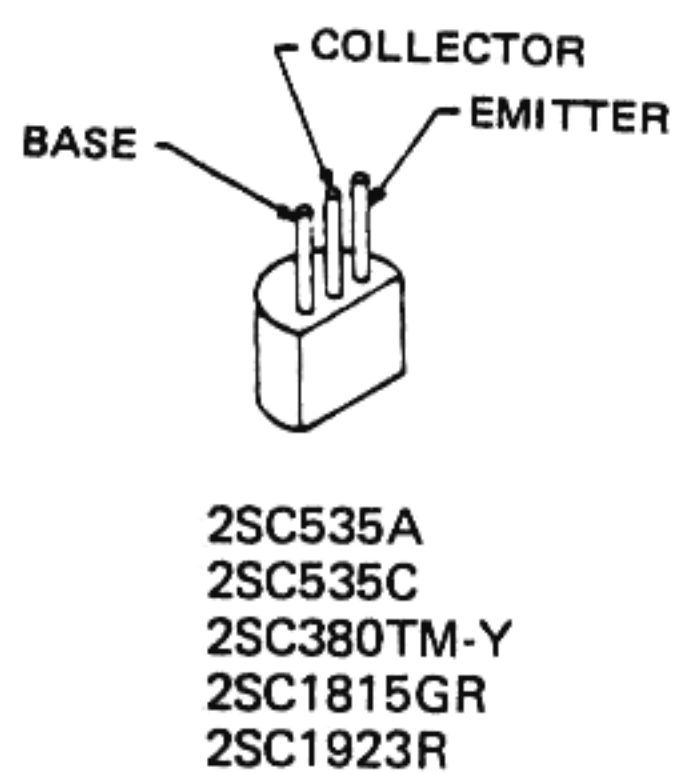
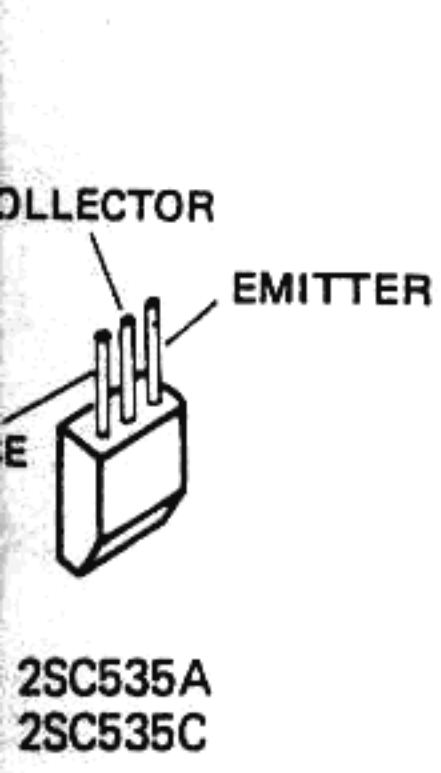
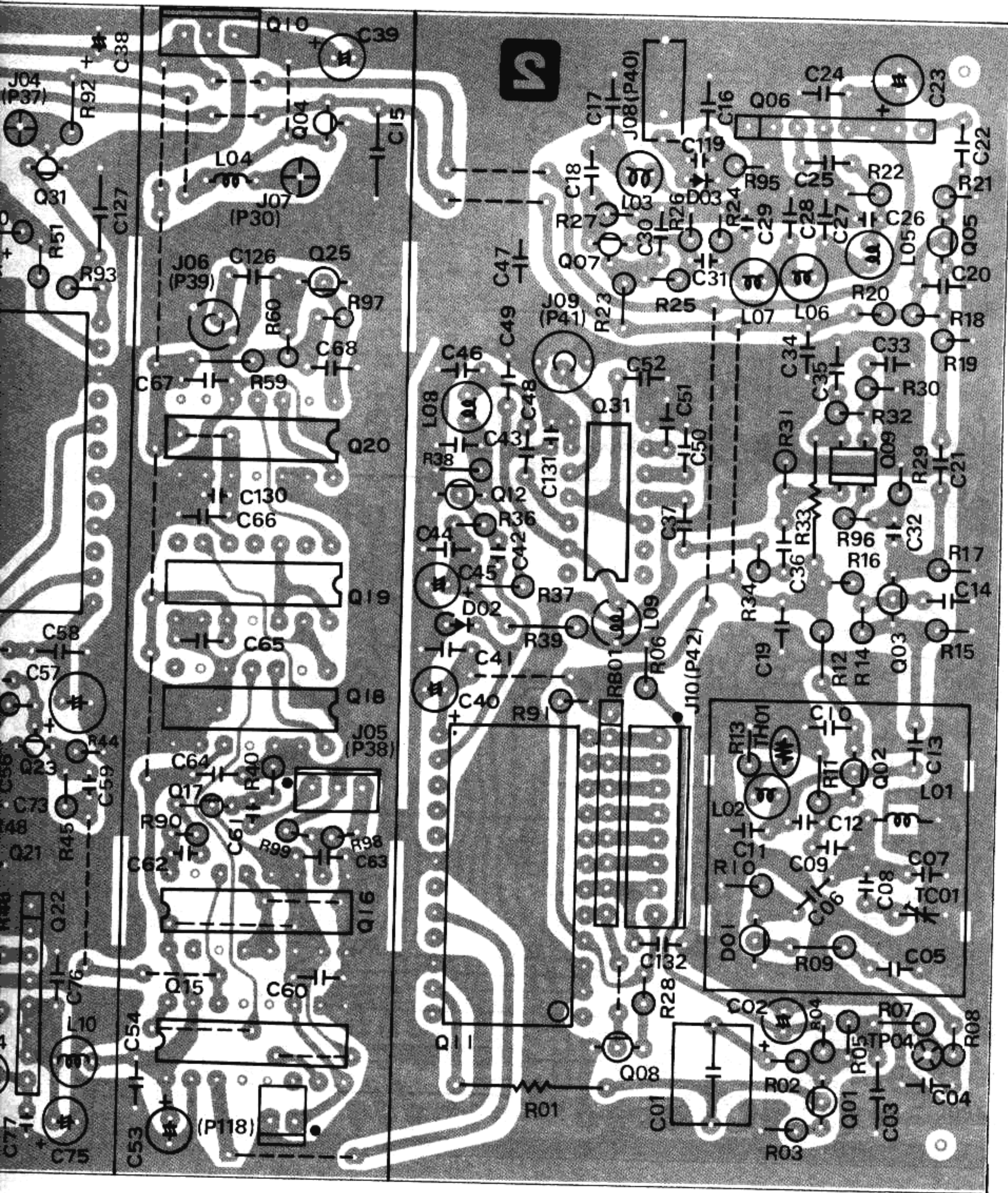

UNIT PARTS LAYOUT (component side)

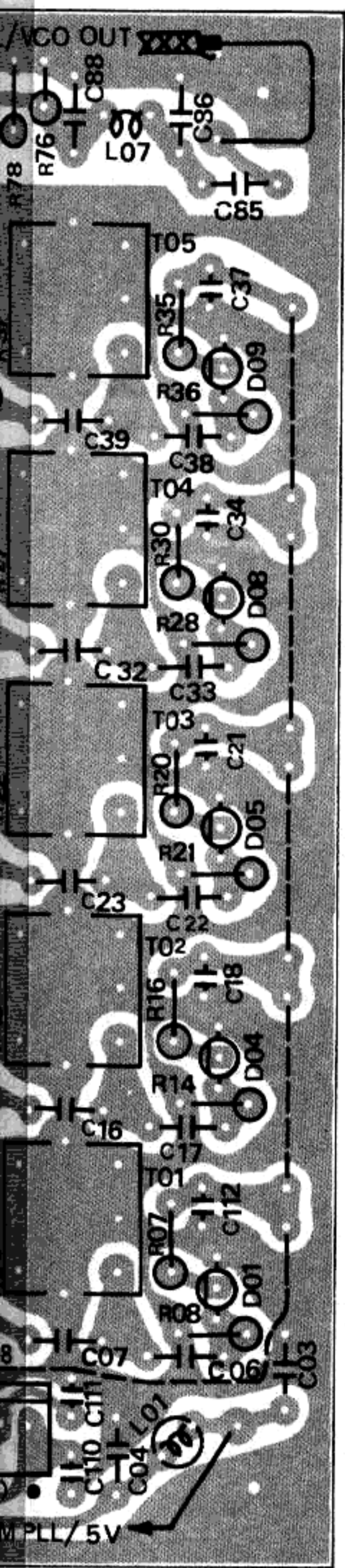

VCO UNIT VOLTAGE CHART

(DC VOLTS)

	E (S)		C (D)		B (G1)		(G2)		REMARKS
	R	T	R	T	R	T	R	T	
Q5001	IN 13.5		COM 0		OUT 9				
Q5002	9		8.9		8.4				VCO → ON
Q5005	9		0		9				VCO → OFF
Q5006									
Q5009									
Q5010									
Q5013									
Q5014									
Q5017									
Q5018									
Q5021									
Q5003	1.5		8.3		0				VCO → ON
Q5004	0		0		0				VCO → OFF
Q5007									
Q5008									
Q5011									
Q5012									
Q5015									
Q5016									
Q5019									
Q5020									
Q5022	1.2		7.8		1.5		4		
Q5023	2.4		7.5		2.6		5		
Q5024	0		0.2		0.8				28 MHz BAND

VCO UNIT VOLTAGE CHART

(DC VOLTS)

	1	2	3	4	5	6	7	8	9	10	11	12	13	14	15	16	REMARKS
Q5025	-	-	-	-	-	-	-	0	-	-	-	-	-	-	-	9	

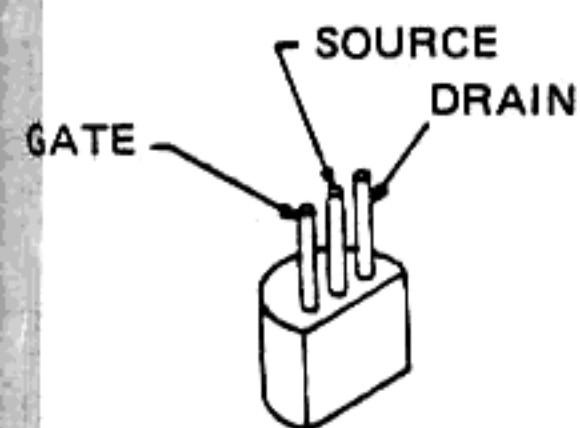

2SK19TM-BL

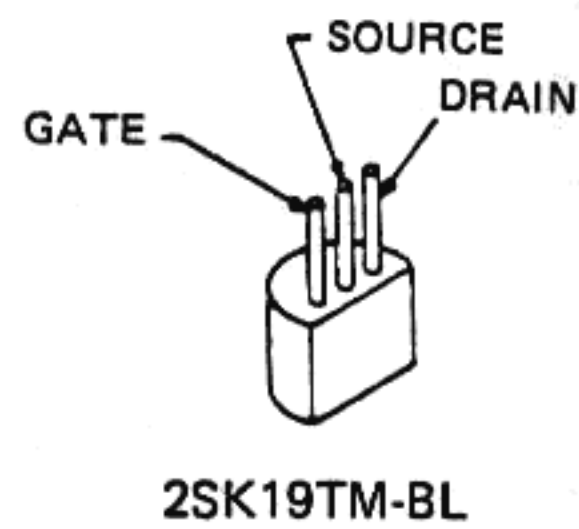
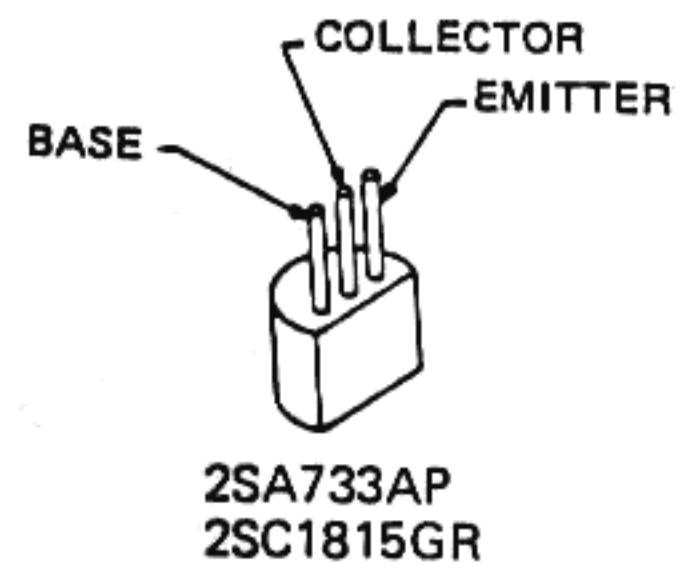
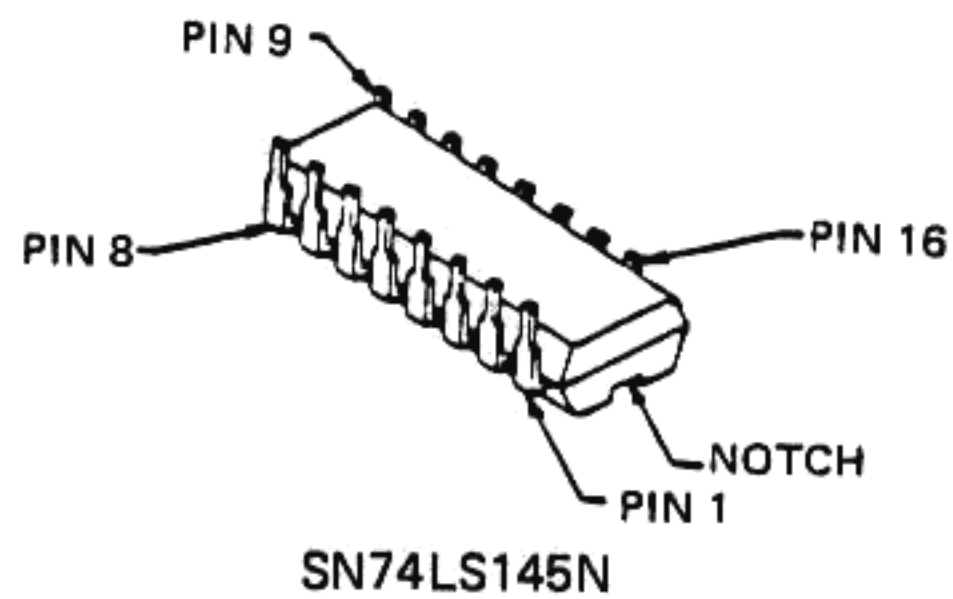
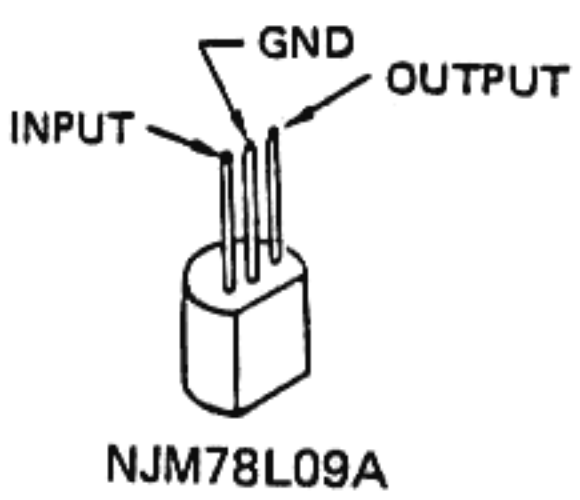
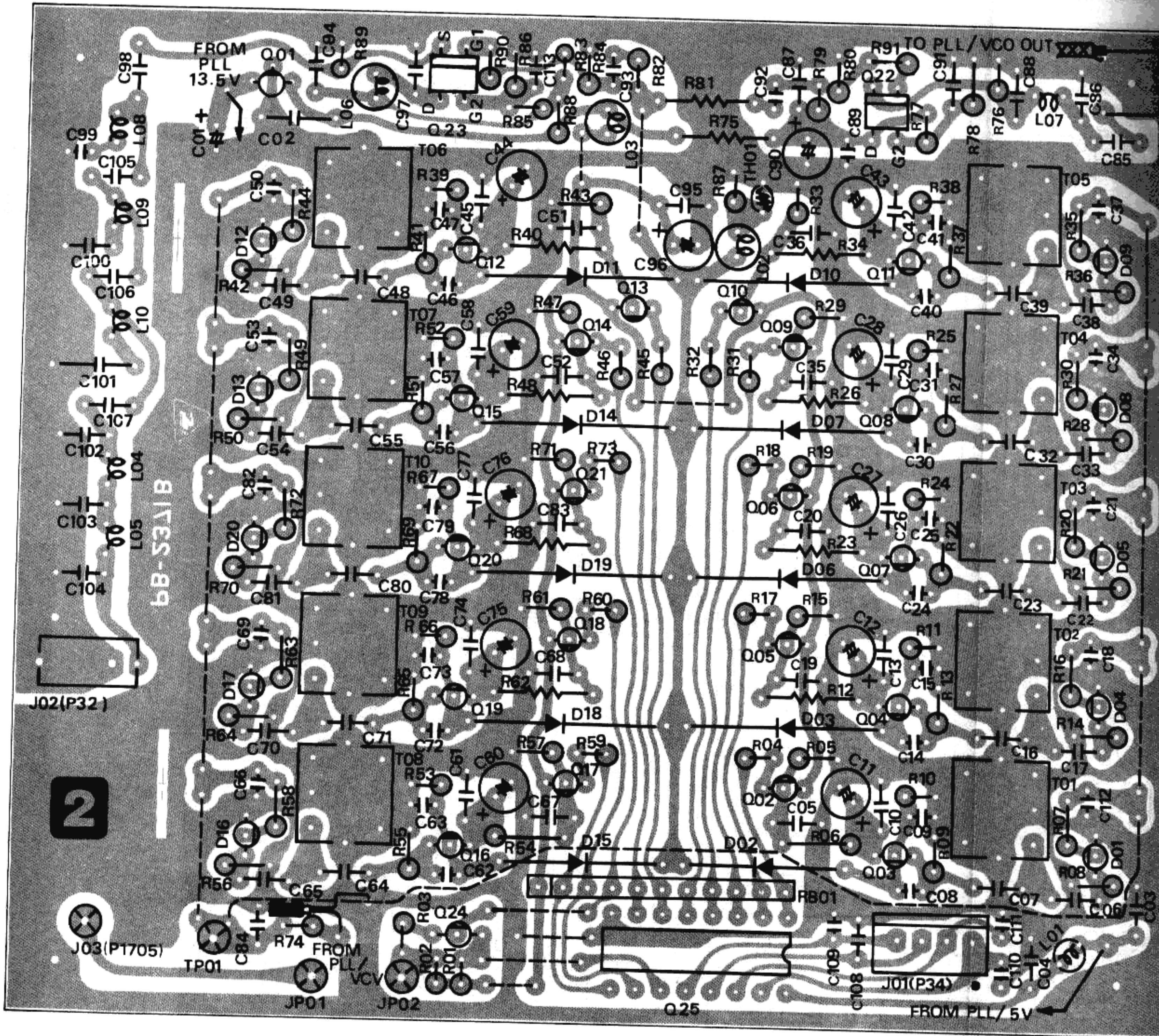

VCO UNIT PARTS LAYOUT (solder side)

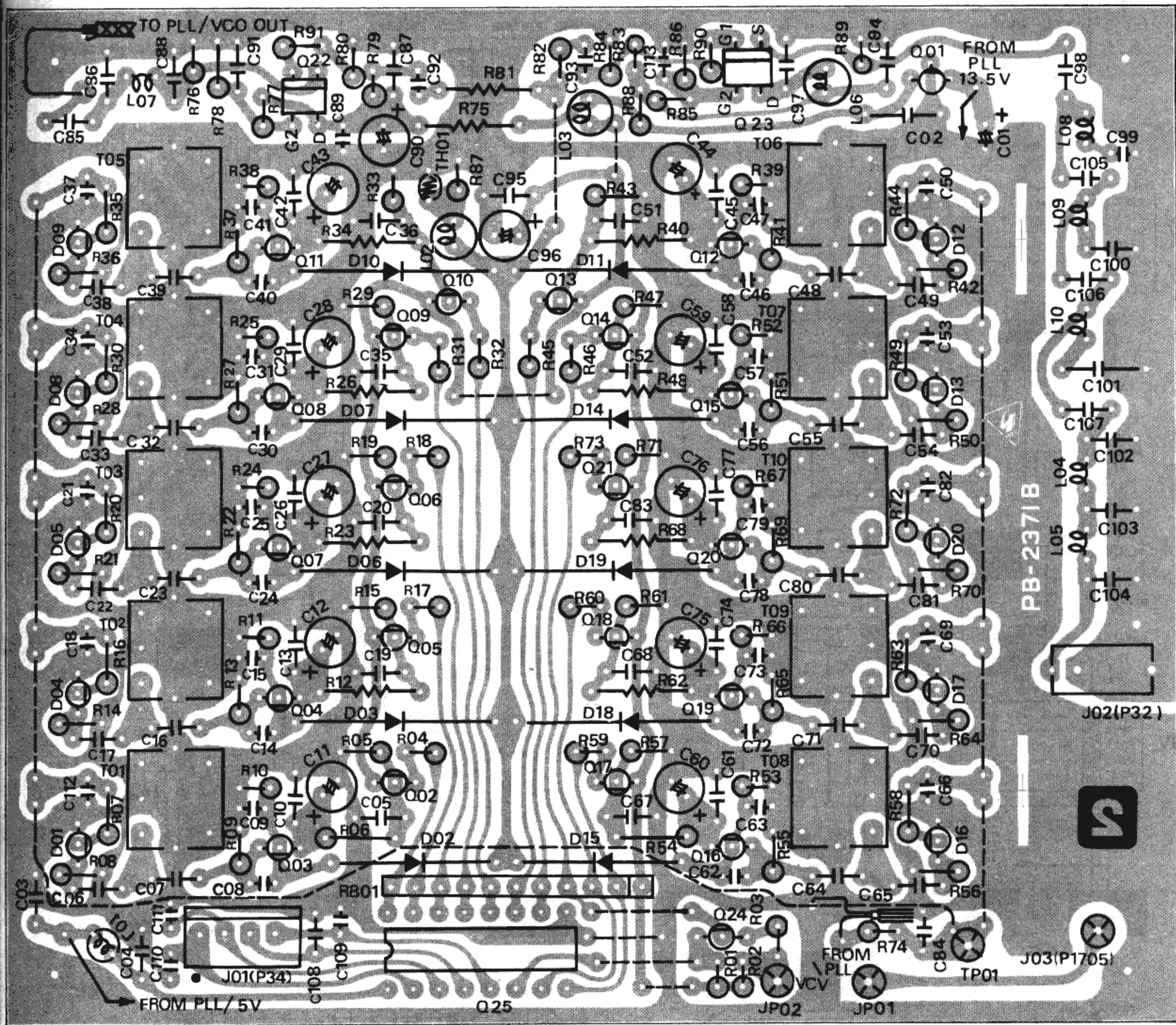

VCO UNIT

VCO UNIT PB-2371A (No.5000)

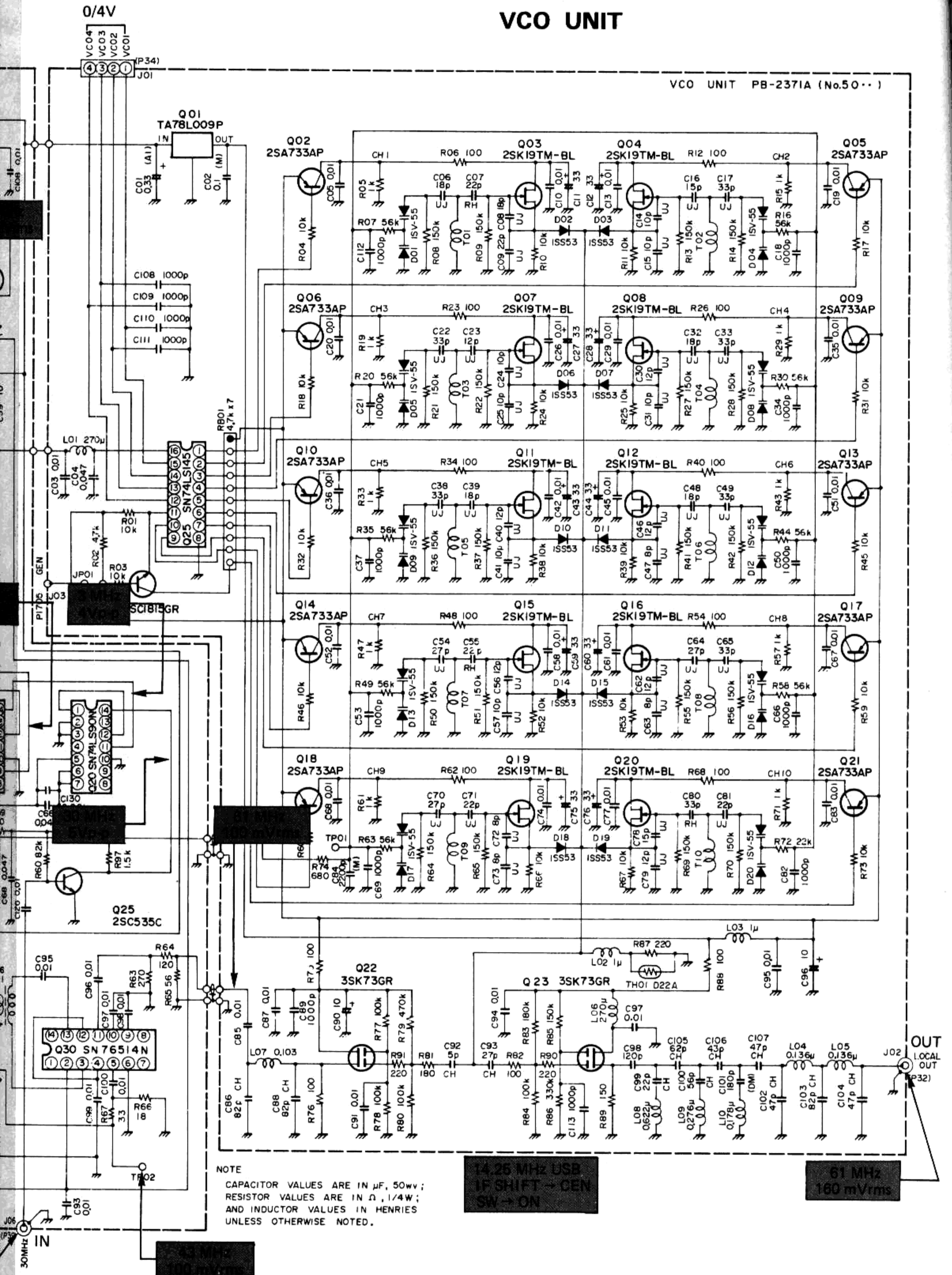

NOTE
CAPACITOR VALUES ARE IN μF , 50V;
RESISTOR VALUES ARE IN Ω , 1/4W;
AND INDUCTOR VALUES IN HENRIES
UNLESS OTHERWISE NOTED.

14.25 MHz USB
IF SHIFT - GEN
SW - ON

61 MHz
160 mVrms

PLL UNIT

0/4V

0/4V

0/9V

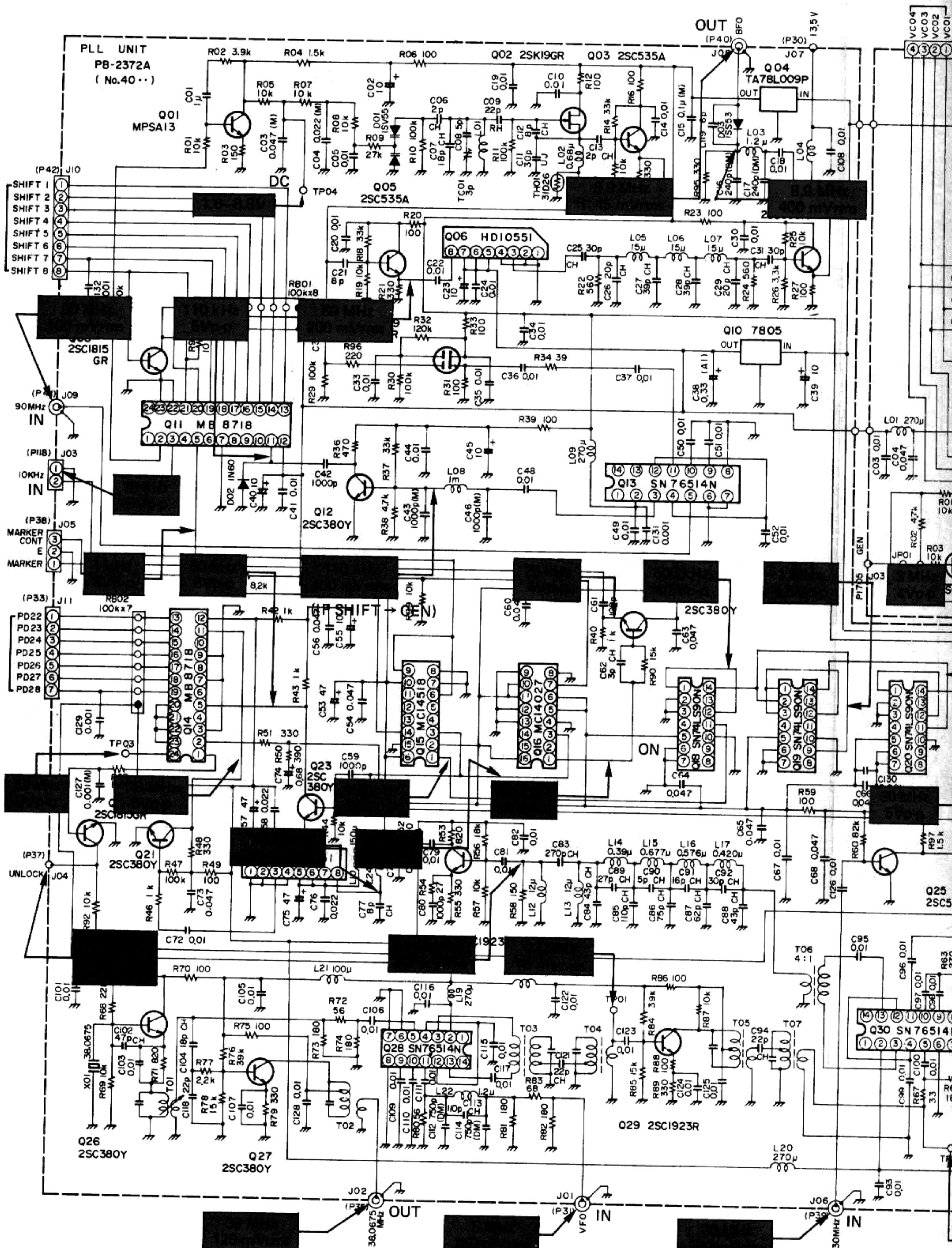

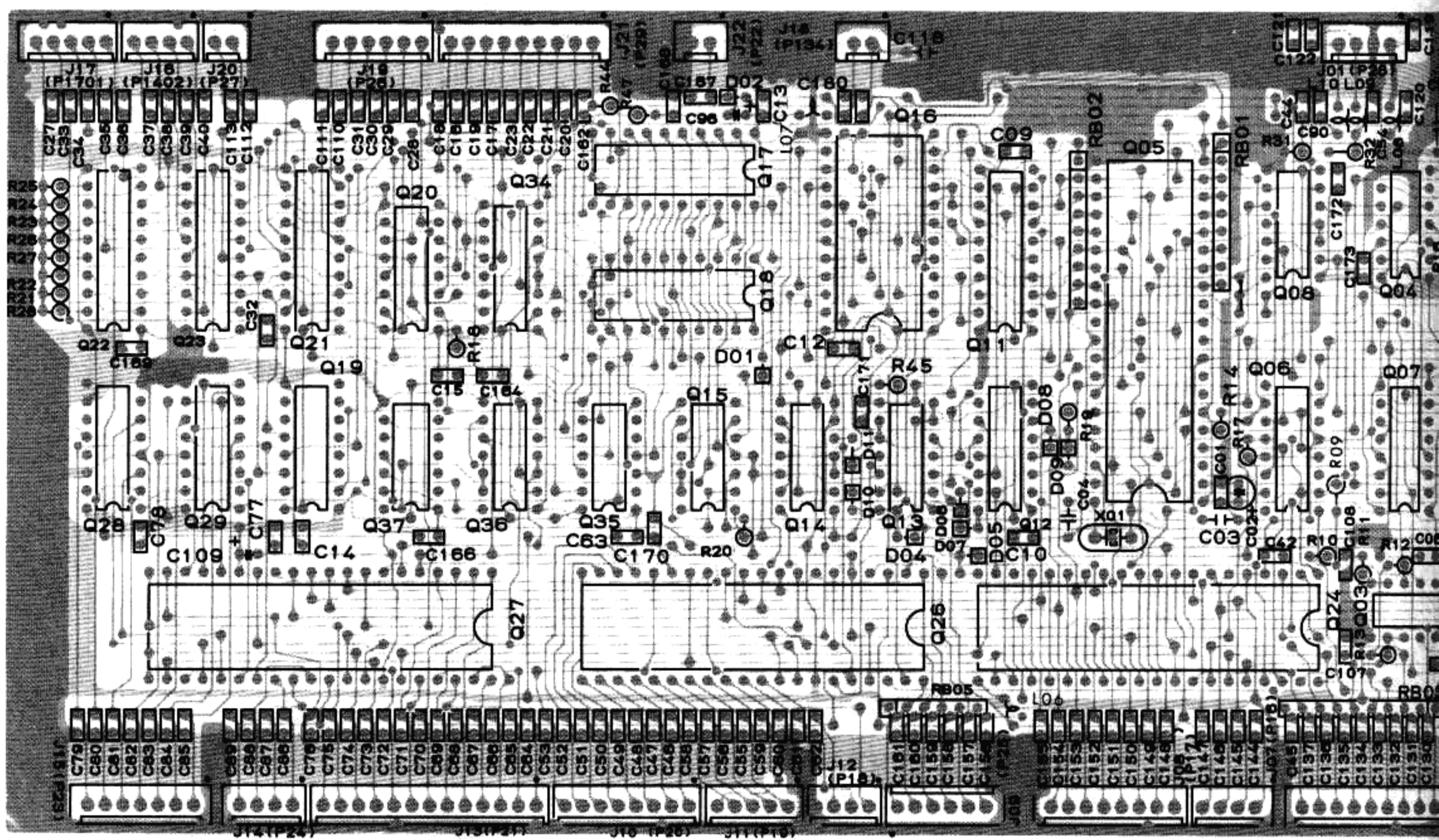
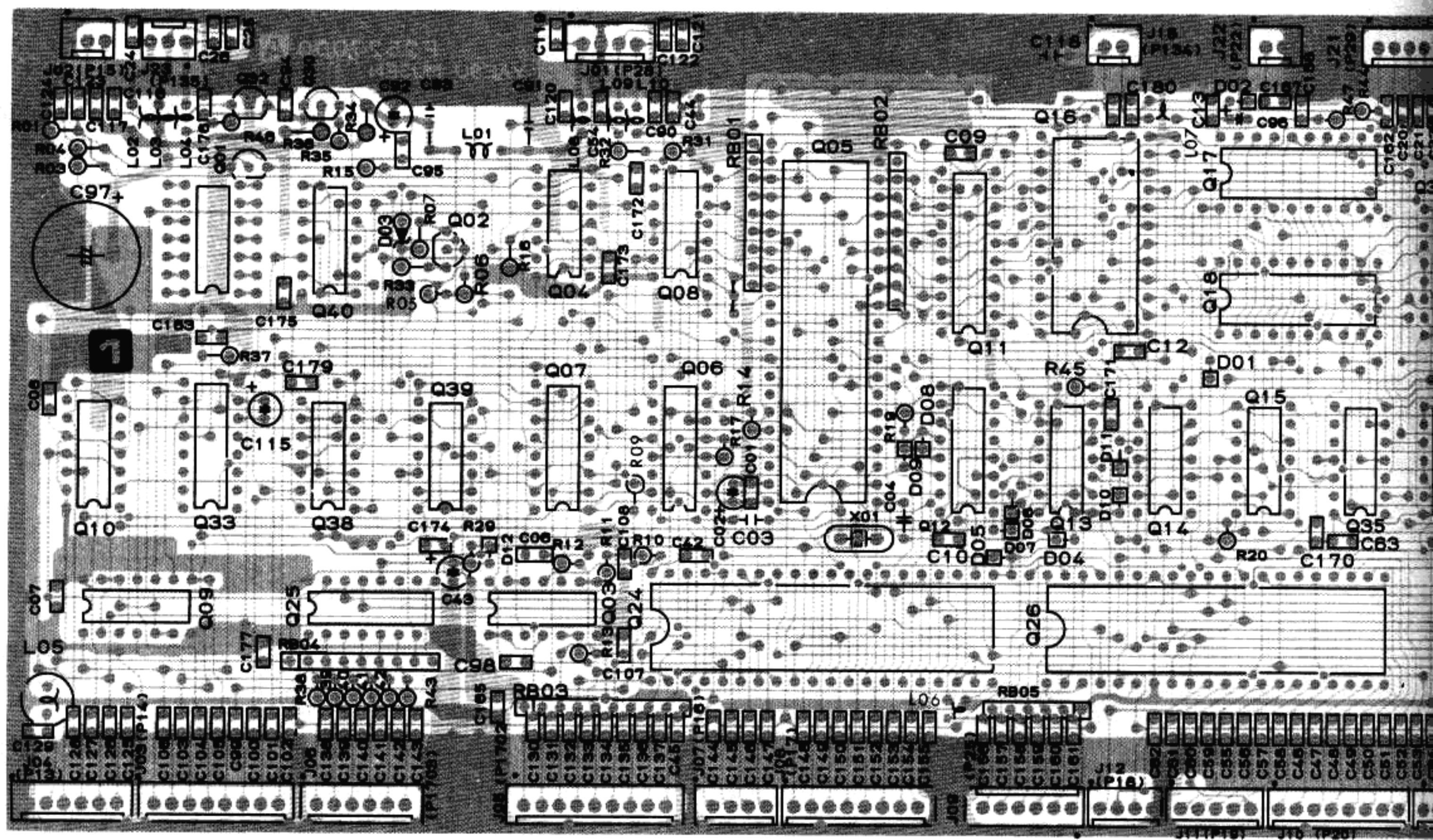

UNIT PARTS LAYOUT

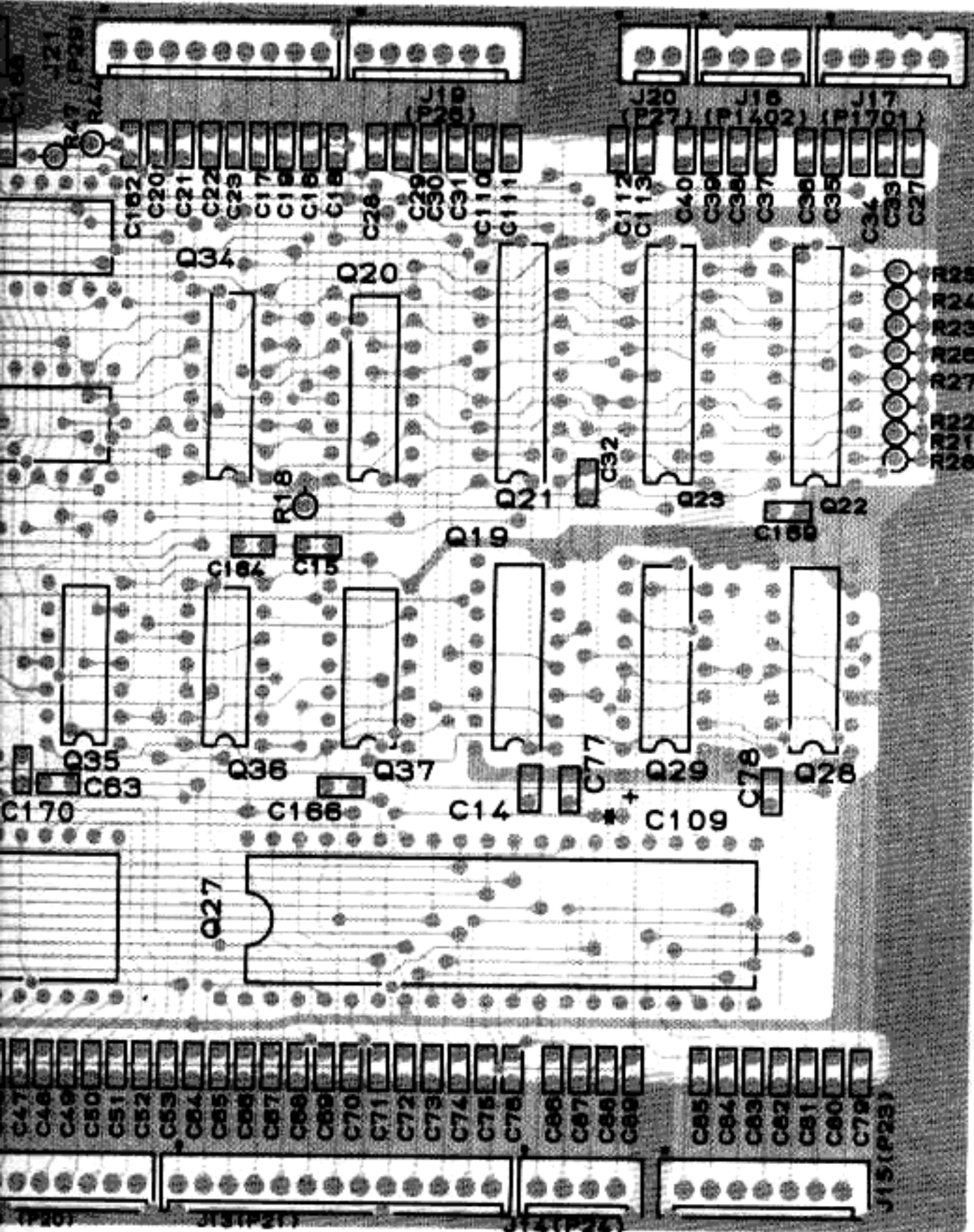

Viewed from component side

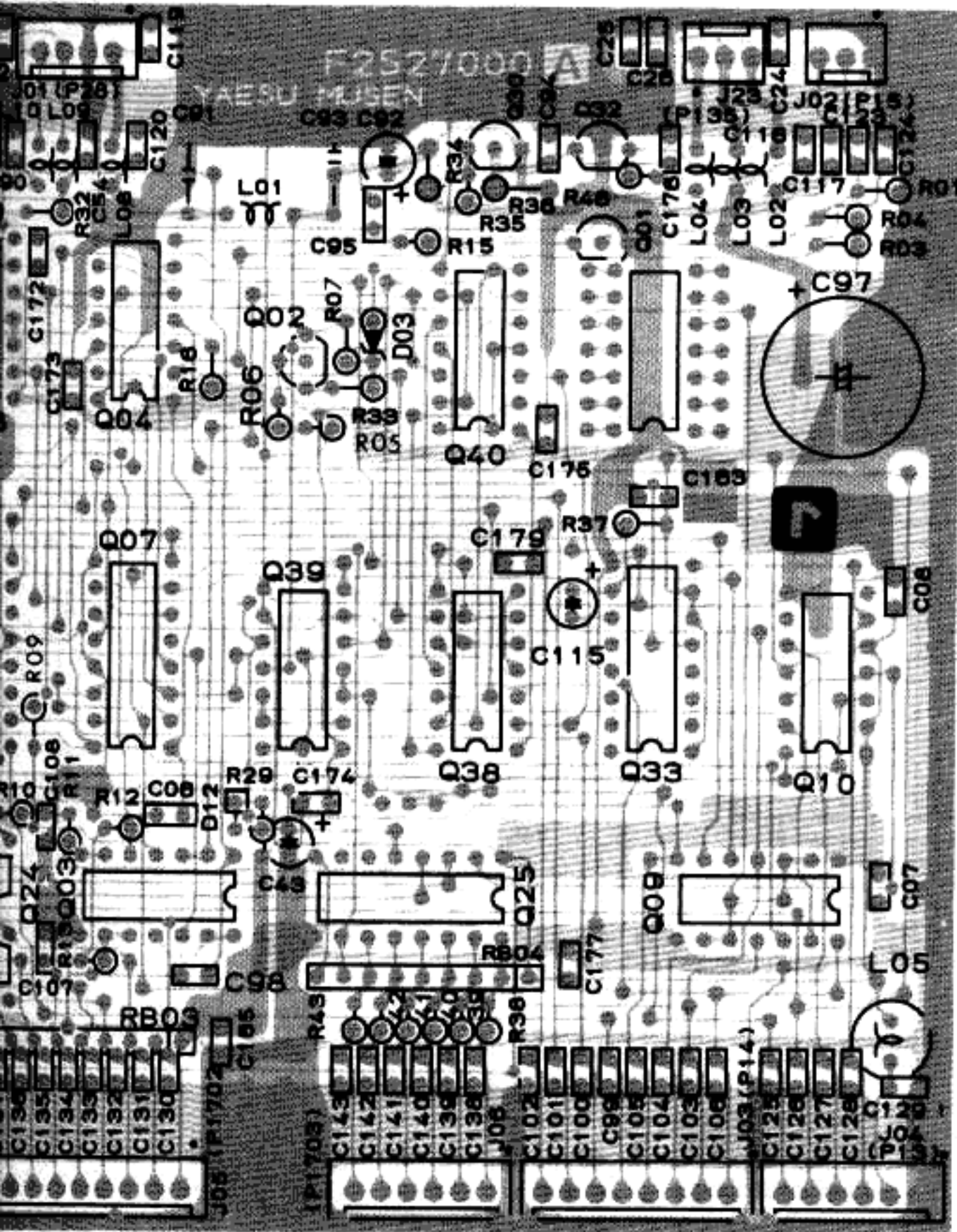

Viewed from solder side

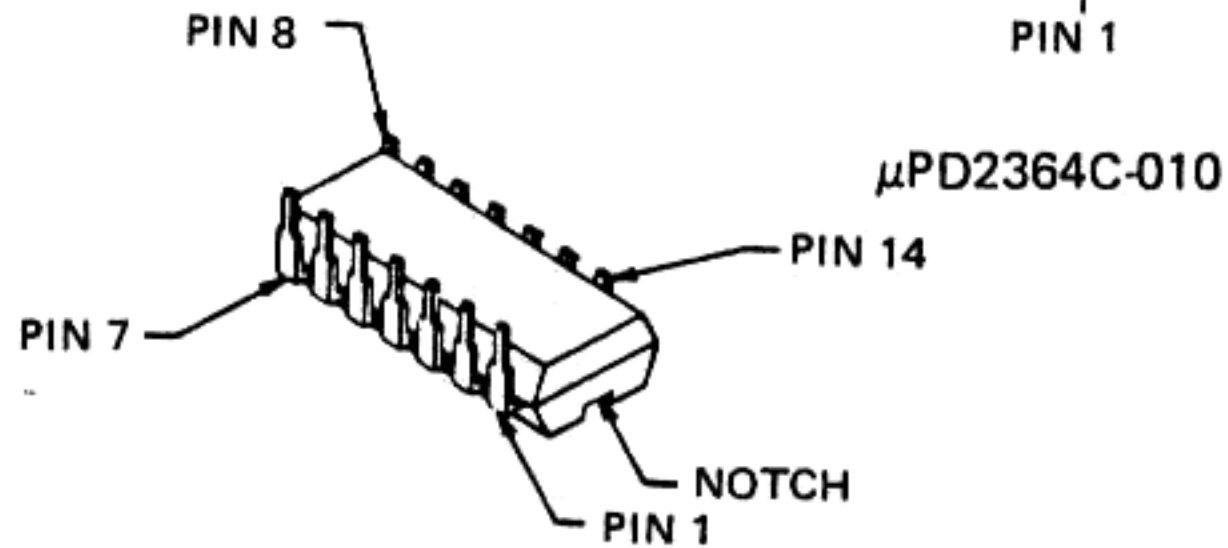
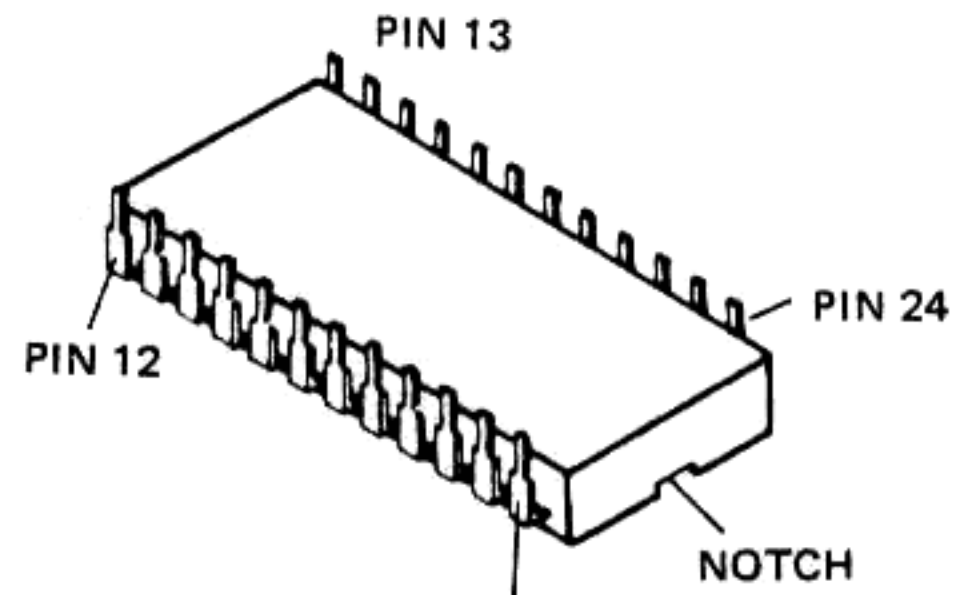
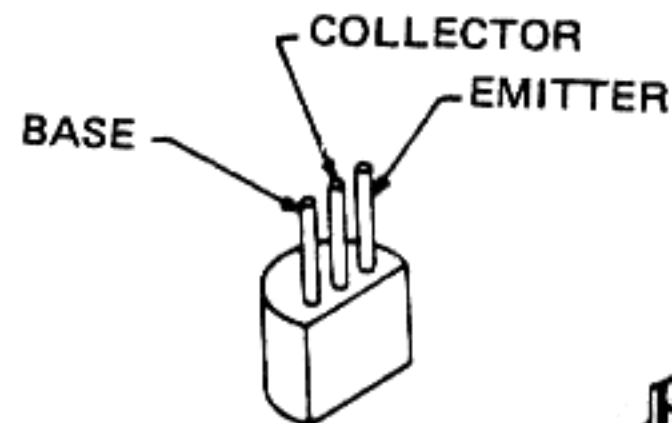
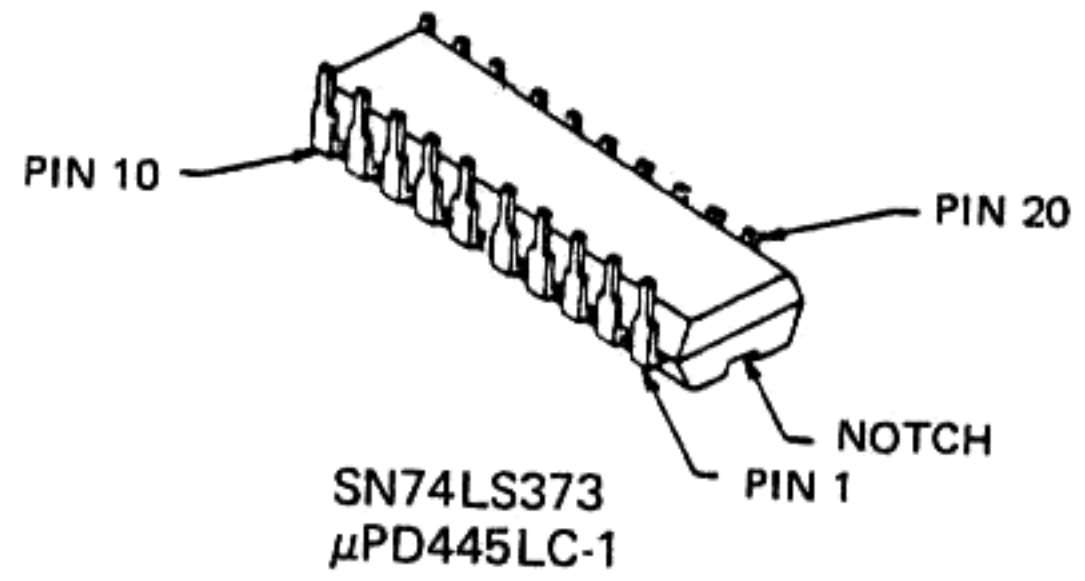

- MC14016
- MC14093B
- SN74LS14
- SN74LS02
- SN74LS74
- SN74LS30
- SN74LS00

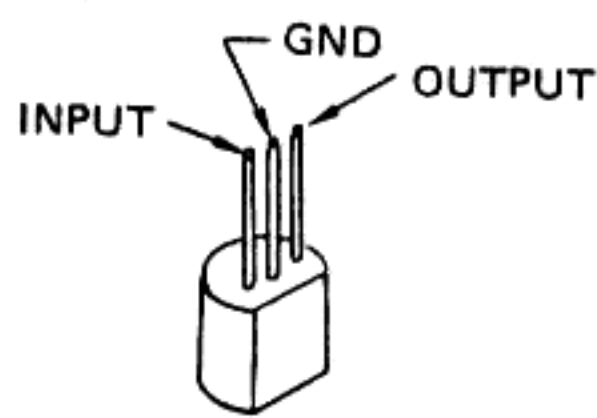

μ PC78L05

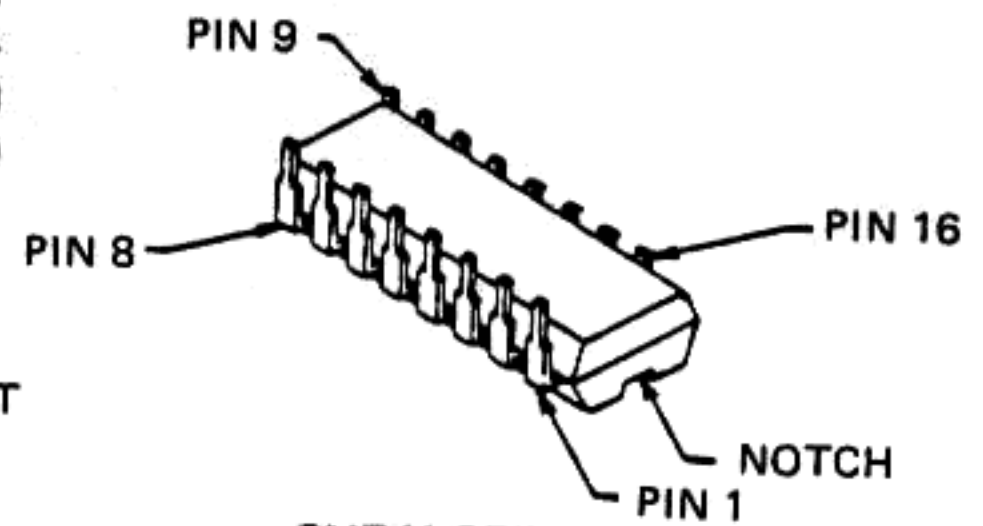

- SN74LS75
- SN74LS190
- SN74LS42
- SN74LS365
- SN74LS145
- SN74LS123
- MC14504

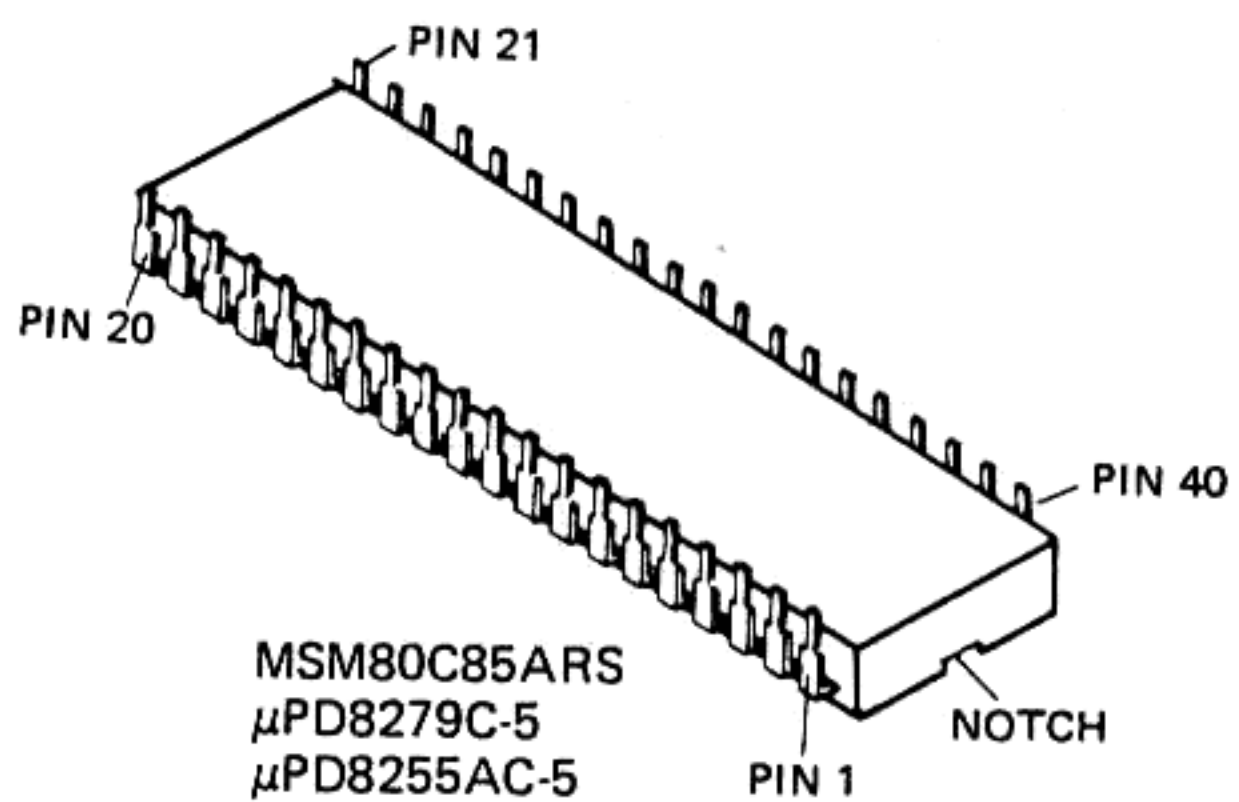

- MSM80C85ARS
- μ PD8279C-5
- μ PD8255AC-5

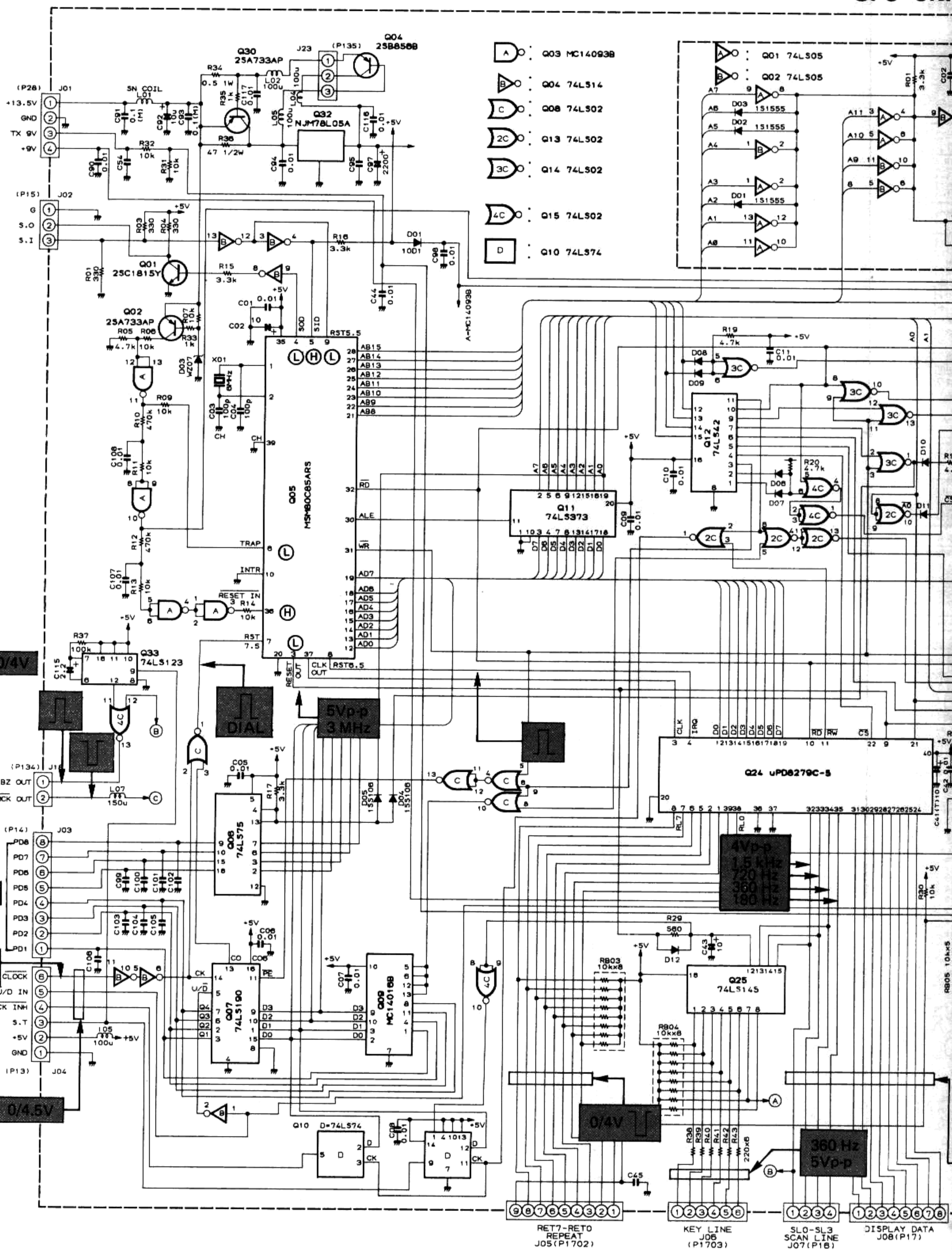

CPU UNIT

CPU UNIT PB-2373 (No.60xx)

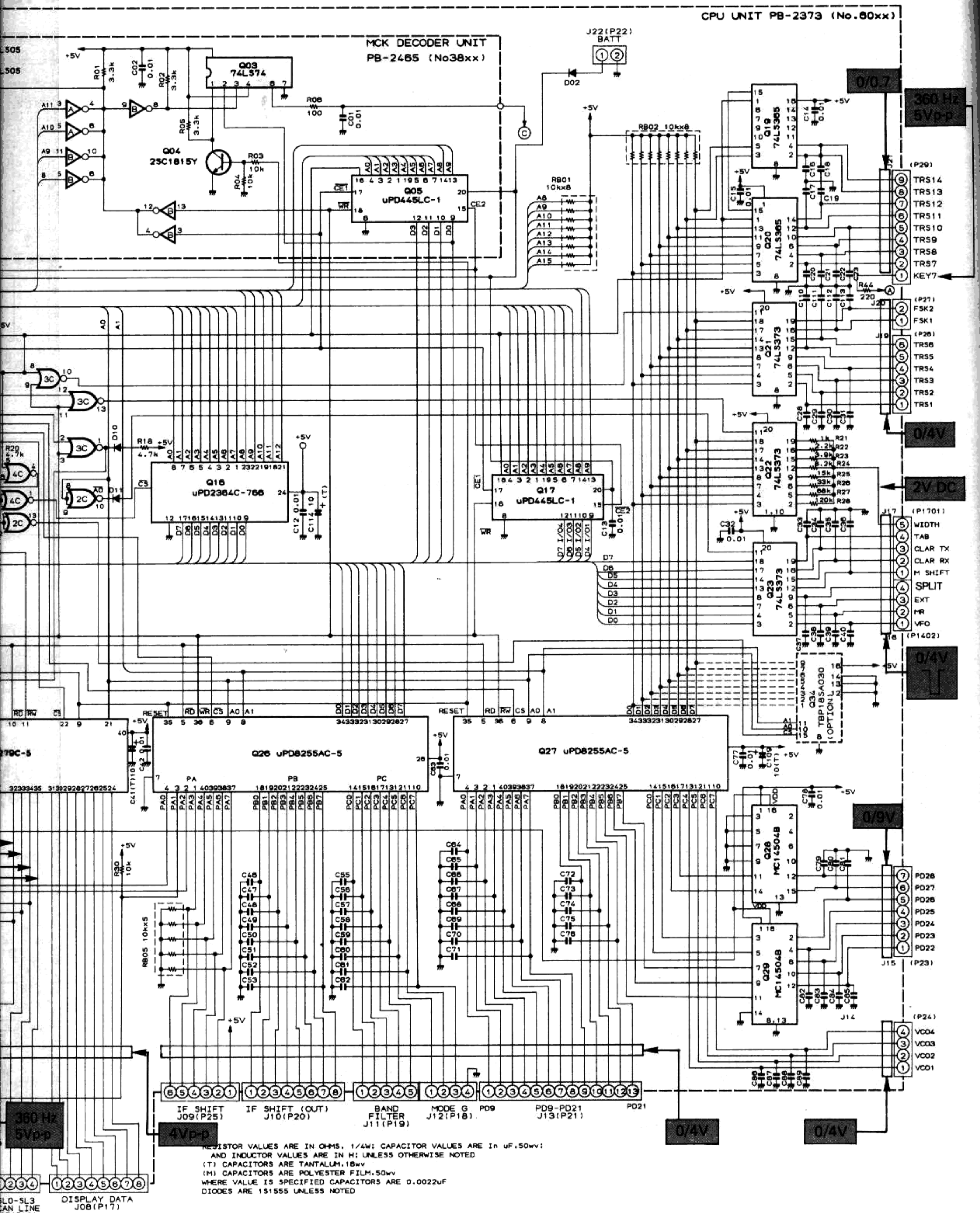

RESISTOR VALUES ARE IN OHMS, 1/4W; CAPACITOR VALUES ARE IN uF, 50V;
 AND INDUCTOR VALUES ARE IN H; UNLESS OTHERWISE NOTED
 (T) CAPACITORS ARE TANTALUM, 18V
 (M) CAPACITORS ARE POLYESTER FILM, 50V
 WHERE VALUE IS SPECIFIED CAPACITORS ARE 0.0022uF
 DIODES ARE 1S1555 UNLESS NOTED

DISPLAY DATA J08 (P17)
 SCAN LINE J07 (P16)

CPU UNIT VOLTAGE CHART

(DC VOLTS)

	E (S)		C (D)		B (G1)		(G2)		REMARKS
	R	T	R	T	R	T	R	T	
Q6001	0		0		0.7				
Q6002	13.5		13.5		13				
Q6030	13.5		13.5		13				
Q6032	IN 13.5		COM 0		OUT 5				

MCK DECODER UNIT VOLTAGE CHART

(DC VOLTS)

	E (S)		C (D)		B (G1)		(G2)		REMARKS
	R	T	R	T	R	T	R	T	
Q3804	0		4		0				

CPU UNIT VOLTAGE CHART

(DC VOLTS)

	1	2	3	4	5	6	7	8	9	10	11	12	13	14	15	16	17	18	19	20	REMARKS	
Q6003	0	0	5	0	5	5	0	0	0	5	0	-	-	5								
Q6004	-	-	-	-	-	-	0	-	-	-	-	-	-	5								
Q6006	-	-	-	-	5	-	-	-	-	-	0	-	-	-								
Q6007	-	-	-	0	-	-	0	-	-	-	-	-	-	-								
Q6008	-	-	-	-	-	0	-	-	-	-	-	-	-	5								
Q6009	-	-	-	-	-	0	-	-	-	-	-	-	-	5								
Q6010	-	-	-	5	-	0	-	-	5	-	-	5	5									
Q6011	0	-	-	-	-	-	-	0	-	-	0	-	-	5	5							
Q6012	-	-	-	-	-	-	0	-	-	-	-	-	-	-	-	-	-	-	-	5		
Q6013	-	-	-	-	-	-	0	-	-	-	-	-	-	5								
Q6014	-	-	-	-	-	-	0	-	-	-	-	-	-	5								
Q6015	-	-	-	-	-	-	0	-	-	-	-	-	-	5								
Q6017	-	-	-	-	-	-	0	-	-	-	-	-	-	-	-	-	-	-	-	5		
Q6019	-	-	-	-	-	-	0	-	-	-	-	-	-	-	-	5						
Q6020	-	-	-	-	-	-	0	-	-	-	-	-	-	-	-	5						
Q6021	0	-	-	-	-	-	-	-	0	-	-	-	-	-	-	5						
Q6022	0	-	-	-	-	-	-	-	0	-	-	-	-	-	-	-	-	-	-	5		
Q6023	0	-	-	-	-	-	-	-	0	-	-	-	-	-	-	-	-	-	-	5		
Q6025	-	-	-	-	-	-	0	-	-	-	0	-	-	-	-	-	-	-	-	5		
Q6028	5	-	0	-	0	-	0	0	0	-	-	-	-	-	-	9						
Q6029	5	-	-	-	-	-	0	-	-	-	-	0	0	-	9							
Q6033	-	-	-	-	-	5	0	-	5	5	-	-	-	-	5							
Q6034	-	-	-	-	-	-	0	-	-	-	0	0	0	-	5							

MCK DECODER UNIT VOLTAGE CHART

(DC VOLTS)

	1	2	3	4	5	6	7	8	9	10	11	12	13	14	15	16	17	18	19	20	REMARKS	
Q3803	5	-	-	5	-	-	0	-	-	-	-	-	-	5								
Q3805	-	-	-	-	-	-	0	-	-	-	-	-	-	-	-	-	-	-	-	5		

FSK UNIT PARTS LAYOUT

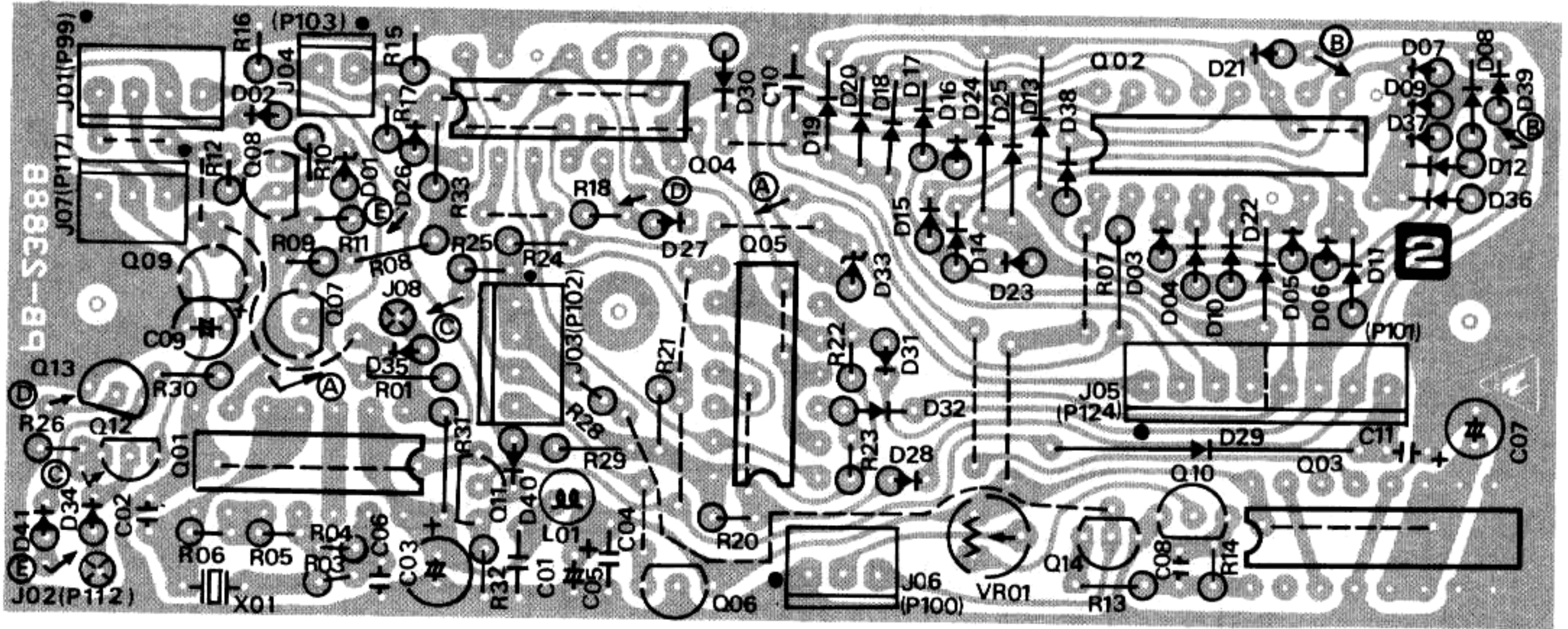

Viewed from component side

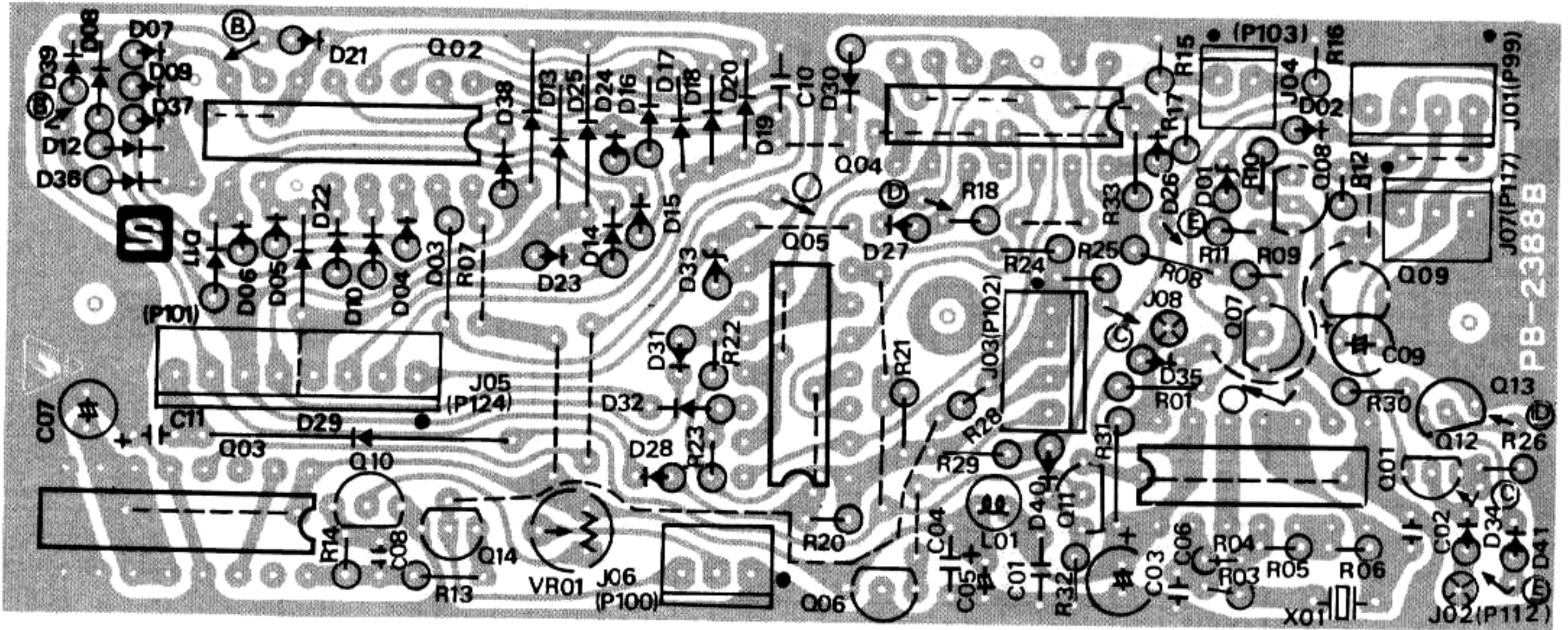

Viewed from solder side

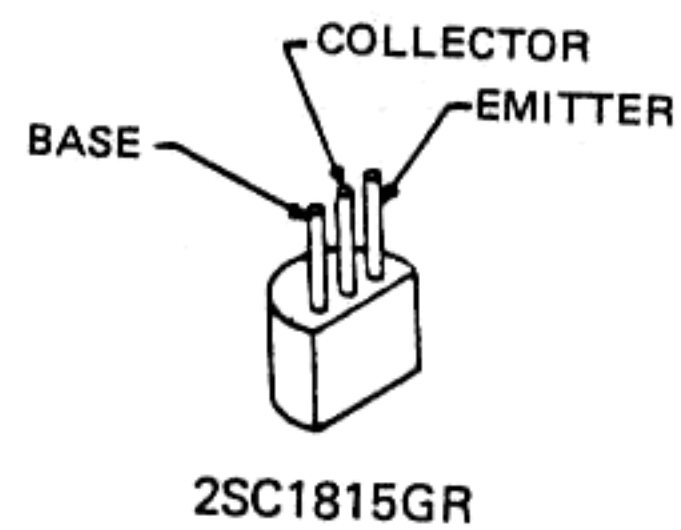
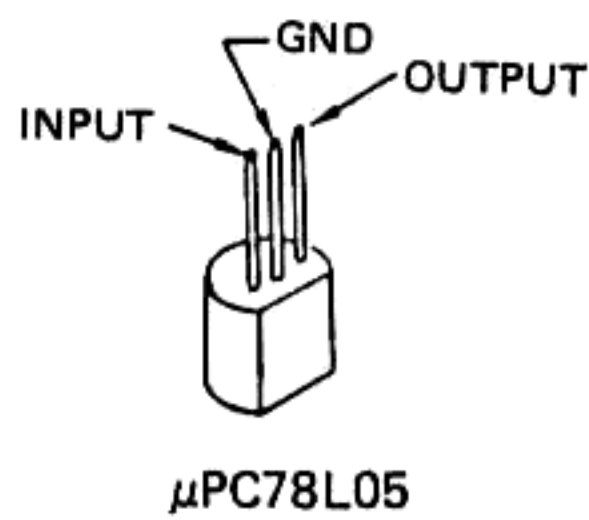
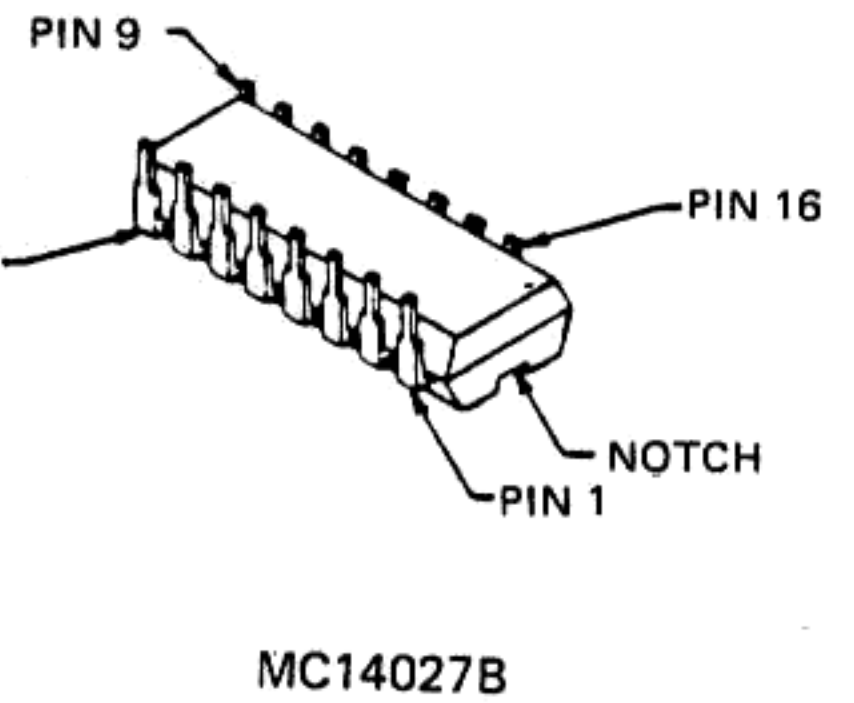
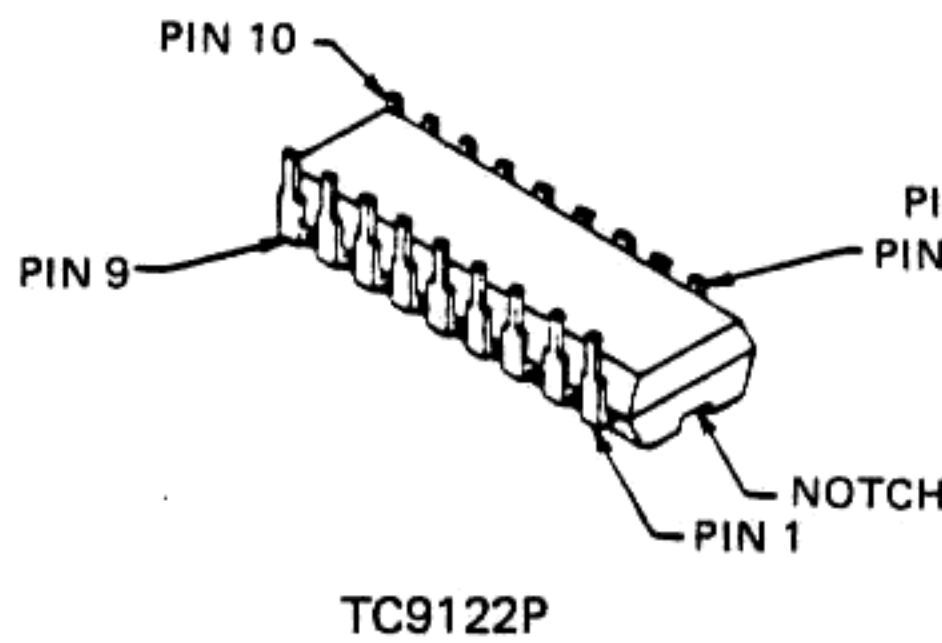
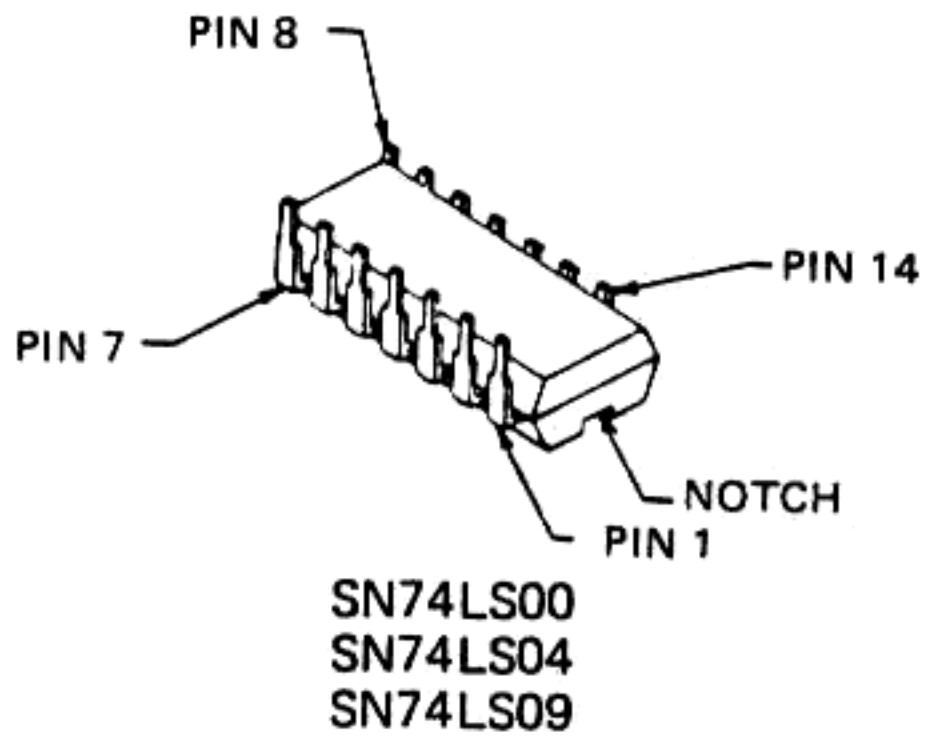

FSK UNIT

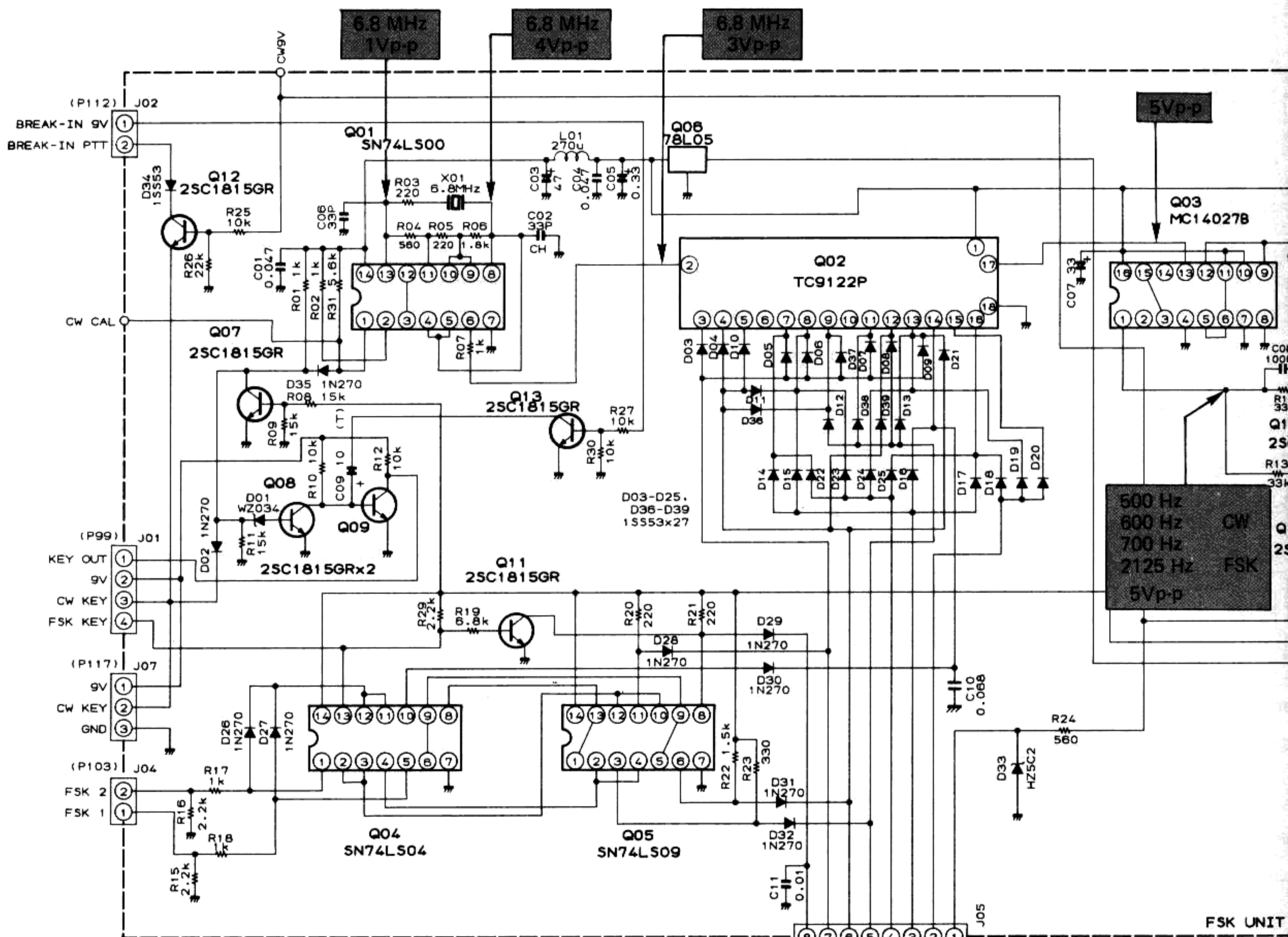

RESISTOR VALUES ARE IN OHMS, 1/4W, AND CAPACITOR VALUES ARE IN μ F, 50wv, AND INDUCTOR VALUES ARE IN HENRIES UNLESS OTHERWISE NOTED (T) CAPACITORS ARE TANTALUM, 18wv

FSK & F CNTL

IN	FREQUENCY	1/N
0 0	RESET	
0 1	2295Hz	740
1 0	2550Hz	866
1 1	2975Hz	571
CW	500Hz	3400
	600Hz	2830
	700Hz	2430

FSK UNIT VOLTAGE CHART

(DC VOLTS)

	E (S)		C (D)		B (G1)		(G2)		REMARKS
	R	T	R	T	R	T	R	T	
Q1807	0		3		0				CW BREAK- IN FSK
Q1808	0		0		0.6				
Q1809	0		5		0				
Q1811	0		0.6		0				
Q1812	6		13		6				
Q1813	0		0		0.6				

FSK UNIT VOLTAGE CHART

	1	2	3	4	5	6	7	8	9	10	11	12	13	14
Q1801	-	5	-	-	-	-	0	-	-	-	-	-	-	5
Q1802	5	-	-	-	-	-	-	-	-	-	-	-	-	-
Q1803	-	-	-	0	5	5	0	0	0	5	5	0	-	-
Q1804	-	-	-	-	-	-	0	-	-	-	-	-	-	5
Q1805	-	-	-	-	-	-	0	-	-	-	-	-	-	5

FSK UNIT

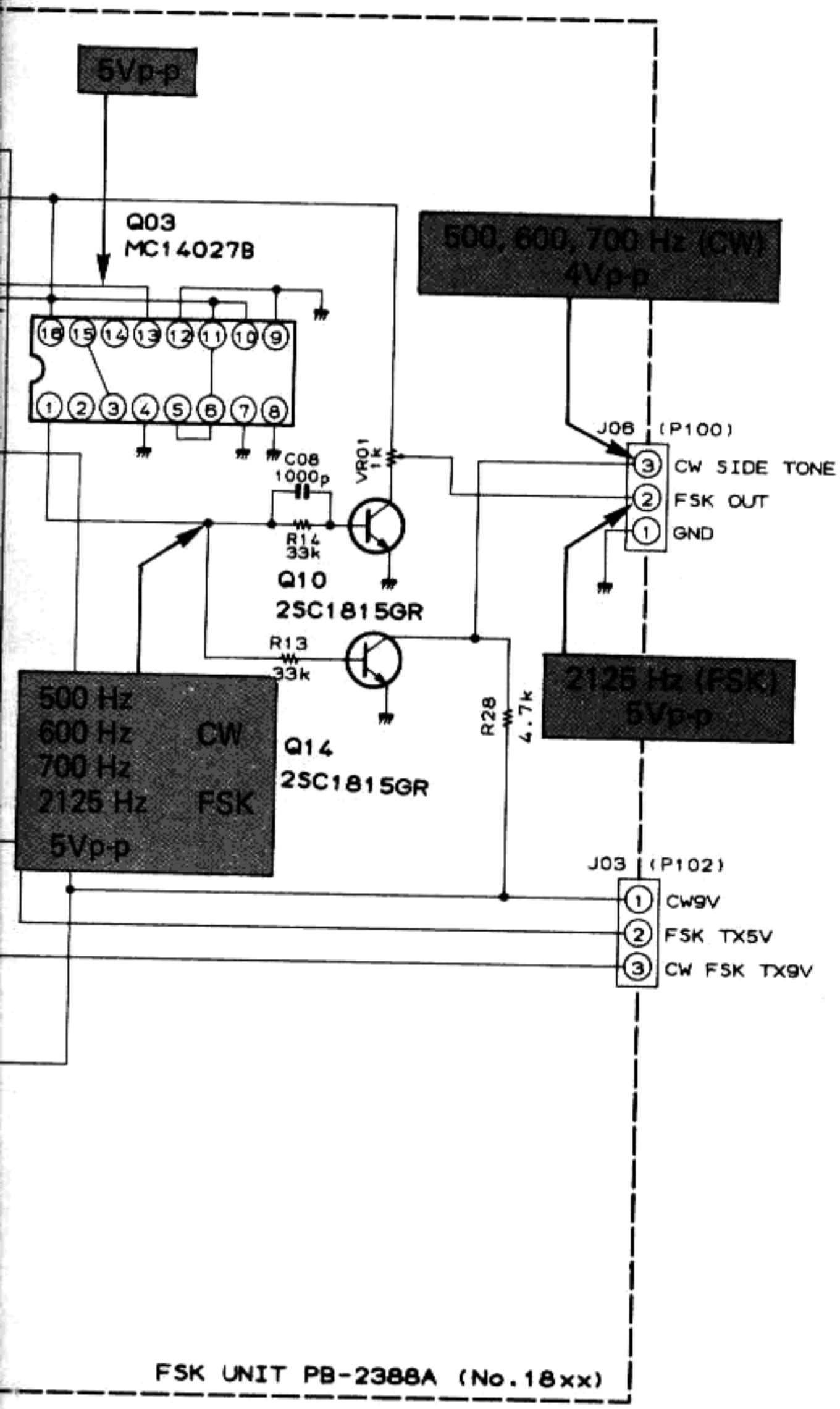

CW BREAK IN

CHART (DC VOLTS)

8	9	10	11	12	13	14	15	16	17	18	REMARKS
-	-	-	-	-	-	5					
-	-	-	-	-	-	-	-	-	-	0	
0	0	5	5	0	-	-	-	5			
-	-	-	-	-	-	5					
-	-	-	-	-	-	5					

LPF UNIT

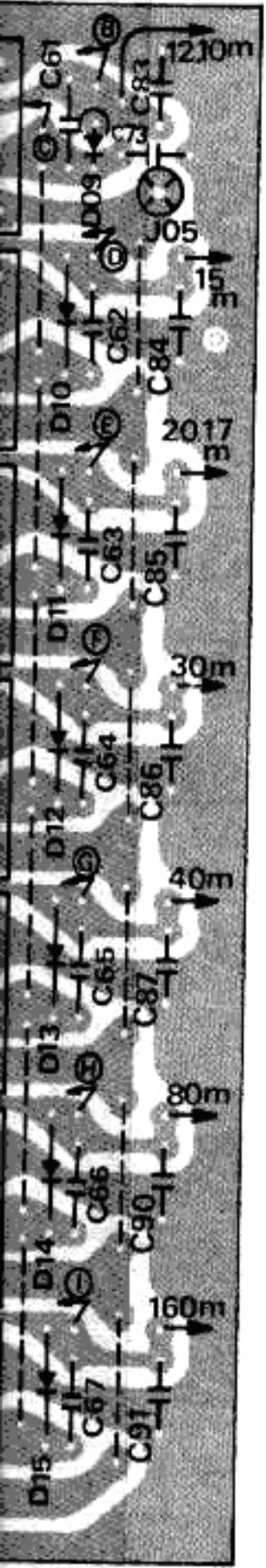

component side

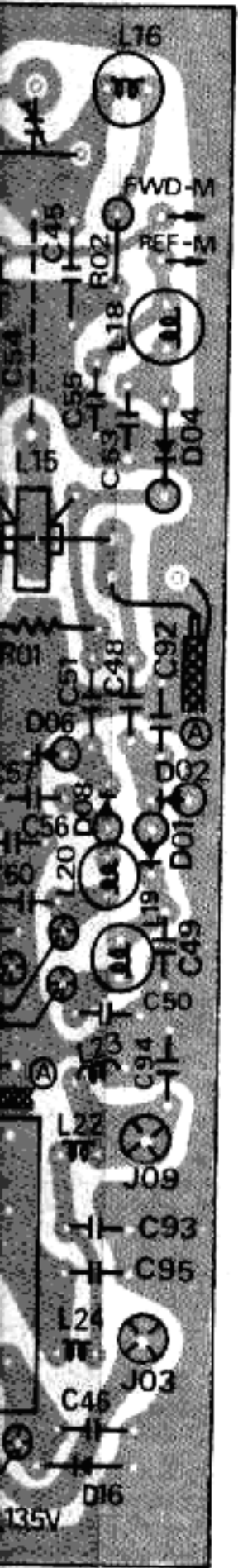

solder side

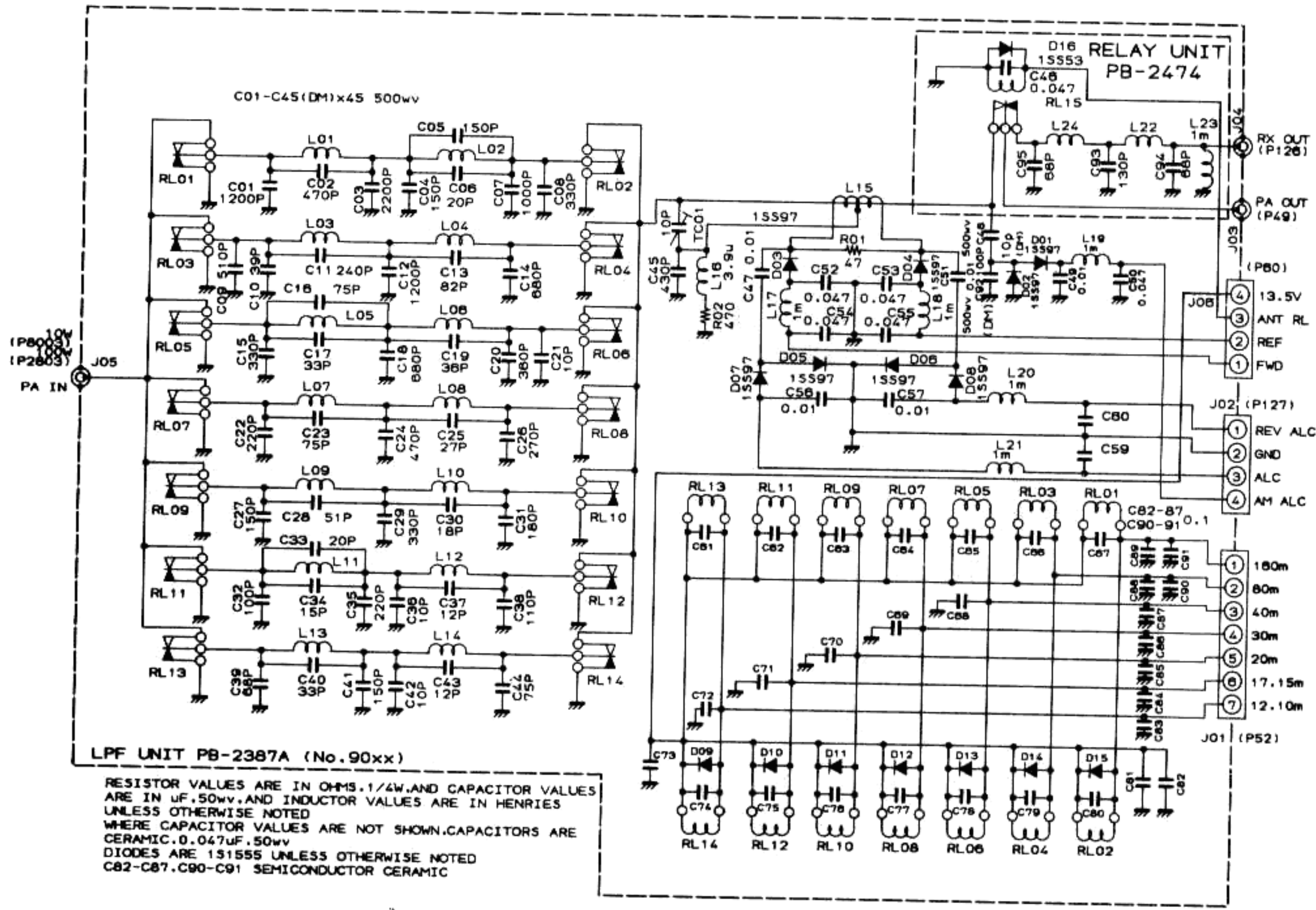

RELAY UNIT PARTS LAYOUT

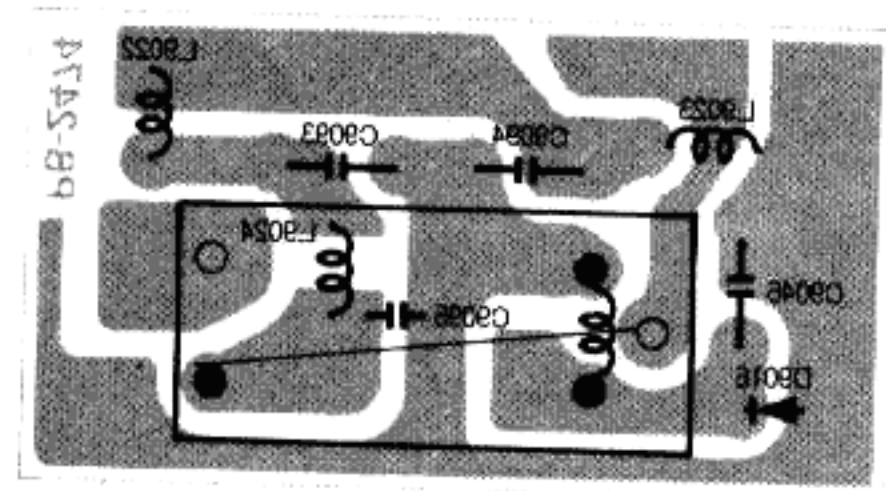

Viewed from component side

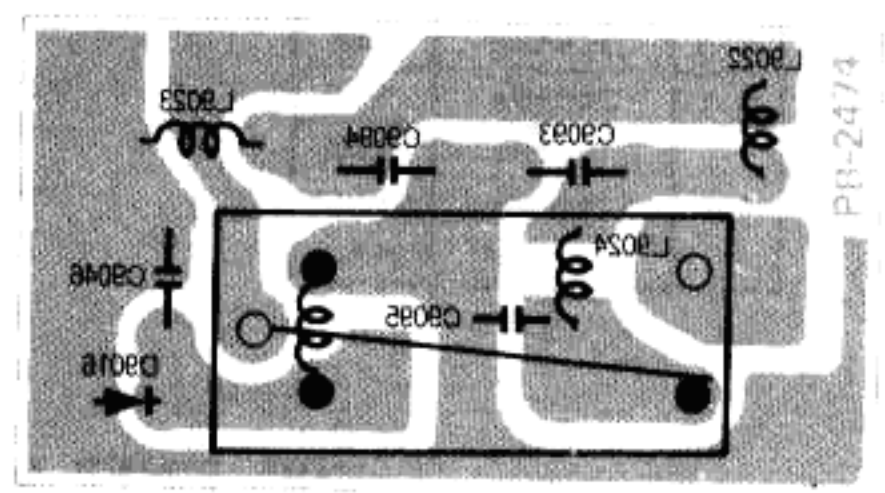

Viewed from solder side

PROTECTOR UNIT PARTS LAYOUT

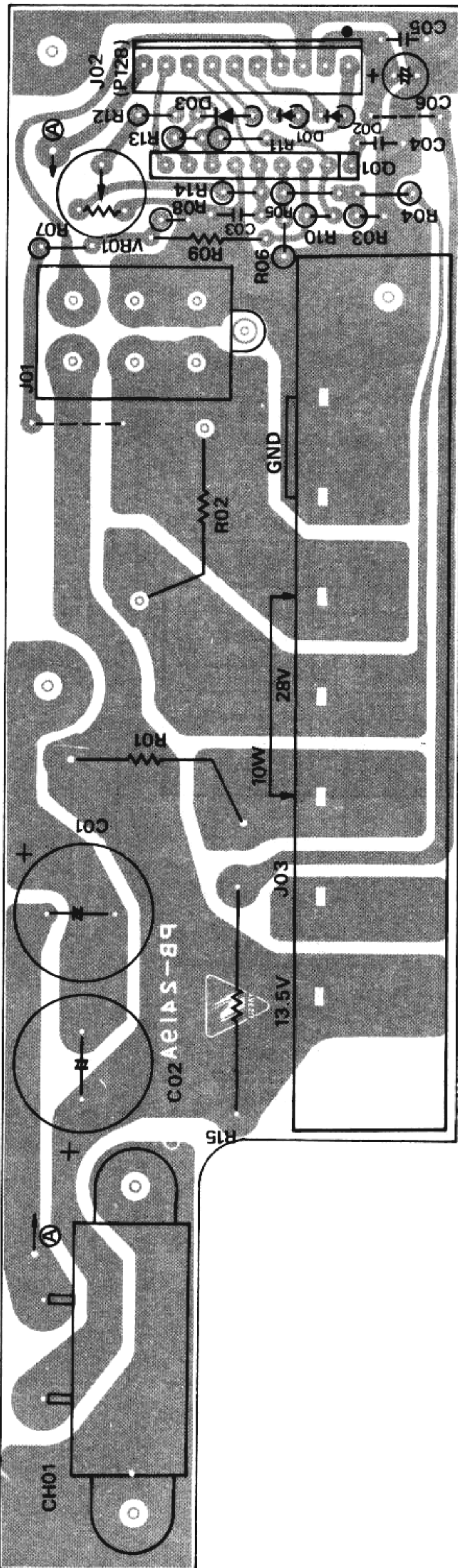

Viewed from component side

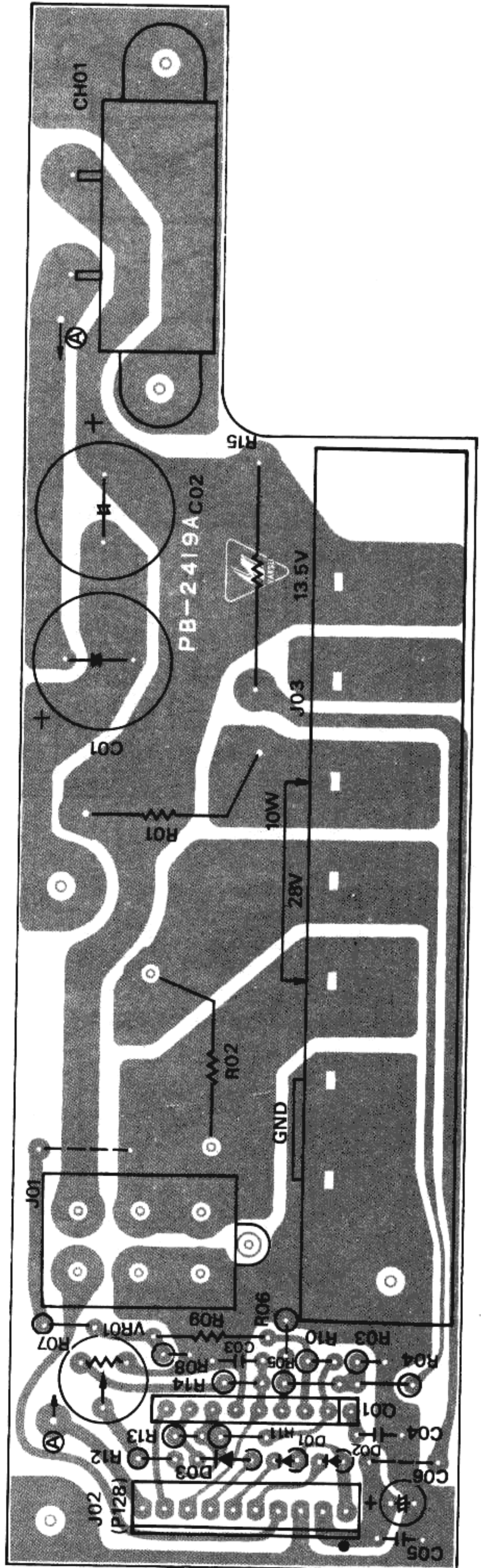

Viewed from solder side

PROTECTOR UNIT

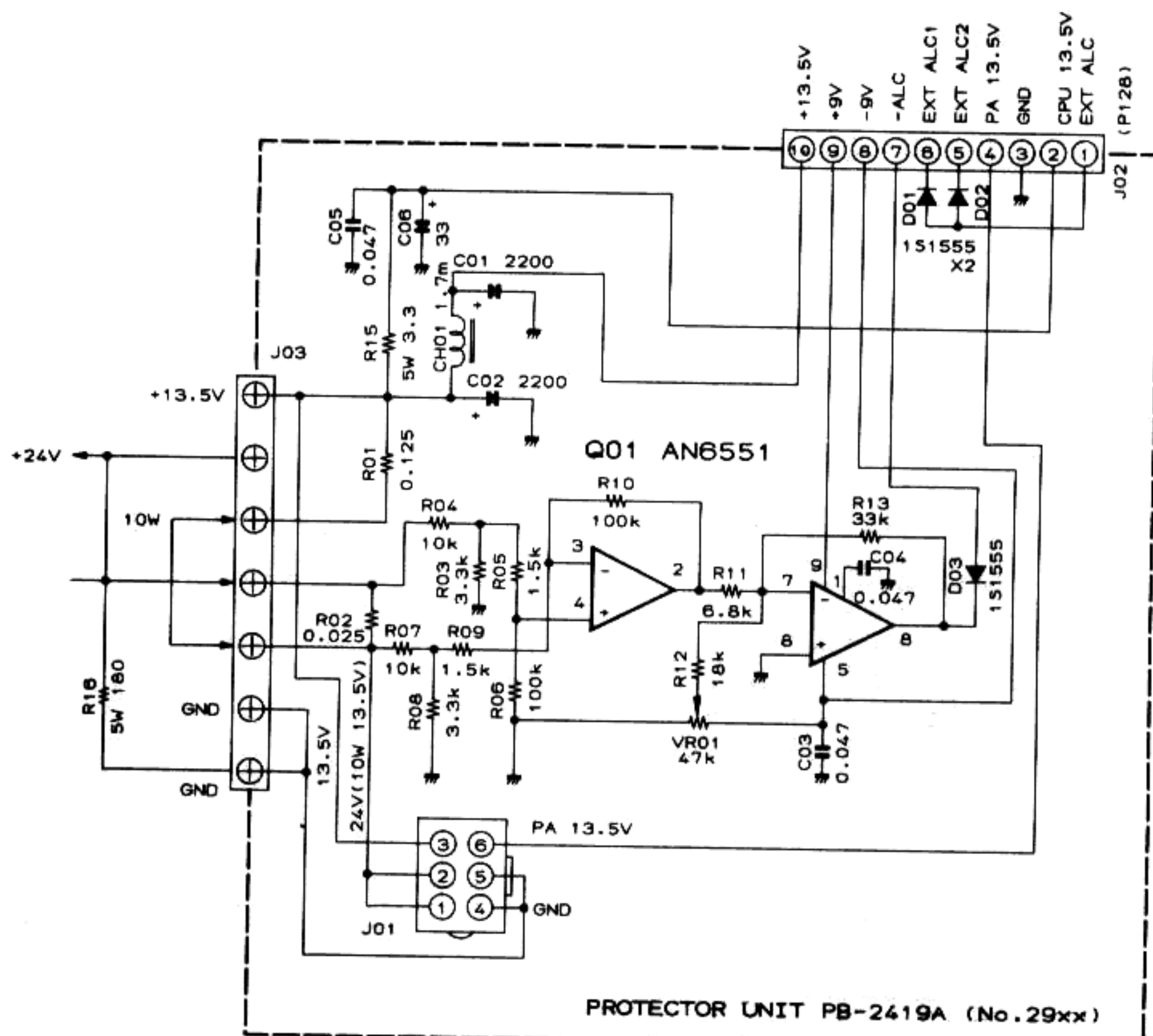

PROTECTOR UNIT PB-2419A (No. 29xx)

RESISTOR VALUES ARE IN OHMS, 1/4W. AND CAPACITOR VALUES ARE IN UF, 50V. AND INDUCTOR VALUES ARE IN HENRIES, UNLESS OTHERWISE NOTED

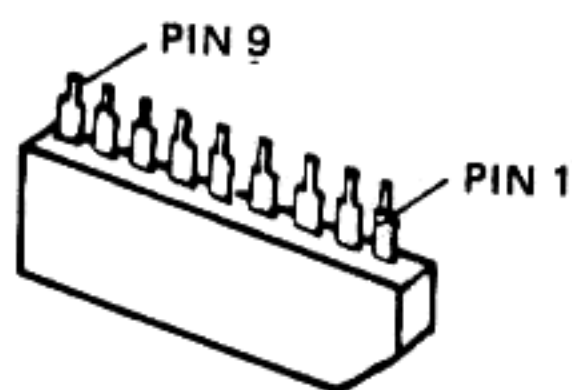

AN6551

PROTECTOR UNIT VOLTAGE CHART (DC VOLTS)

	1	2	3	4	5	6	7	8	9	REMARKS
Q2901	9	-	-	5.7	-9	0	-	-	9	

DIAL UNIT

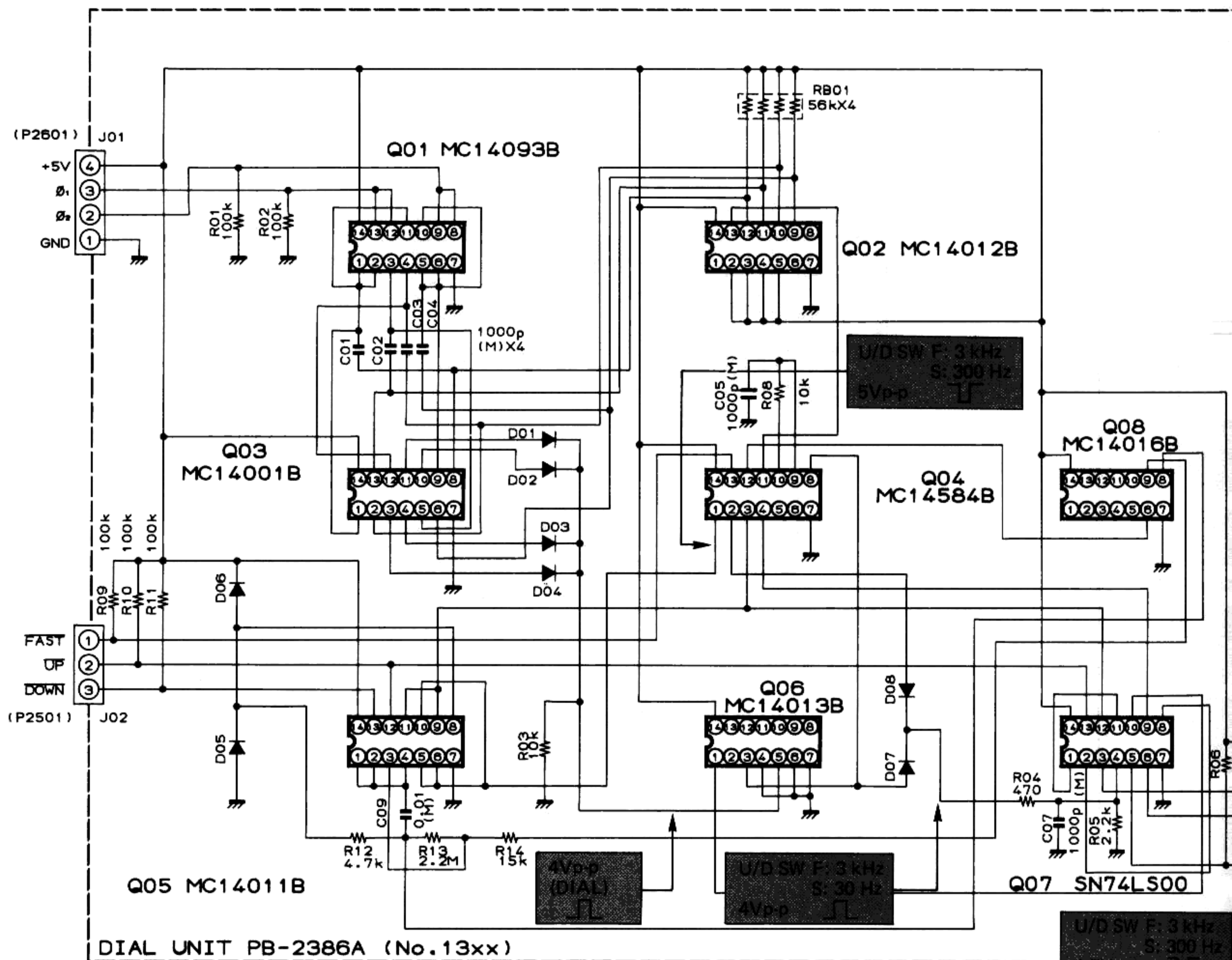

DIAL UNIT PB-2386A (No. 13xx)

RESISTOR VALUES ARE IN OHMS, 1/4W, AND CAPACITOR VALUES ARE IN μ F, 50V, AND INDUCTOR VALUES ARE IN HENRIES, UNLESS OTHERWISE NOTED
 DIODES ARE 1S1555
 (M) CAPACITORS ARE POLYESTER FILM TYPE, 50V

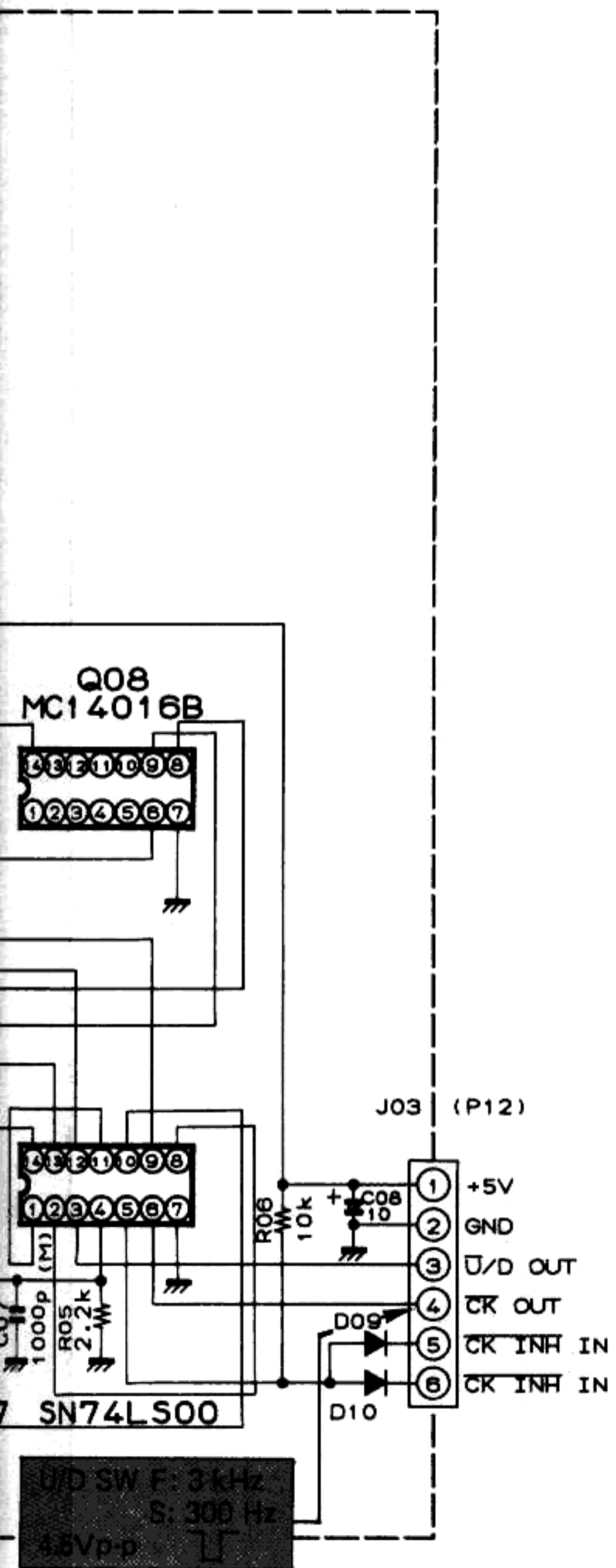

DIAL UNIT VOLTAGE CHART (DC VOLTS)

	1	2	3	4	5	6	7	8	9	10	11	12	13	14	REMARKS
Q1301	-	-	-	-	-	-	0	-	-	-	-	-	-	5	
Q1302	-	5	5	5	5	-	0	-	-	-	-	-	-	5	
Q1303	-	-	-	-	-	-	0	-	-	-	-	-	-	5	
Q1304	-	-	-	-	-	-	0	-	-	-	-	-	-	5	
Q1305	-	-	-	-	-	-	0	-	-	-	-	-	-	5	
Q1306	-	-	-	0	-	-	0	-	-	-	-	-	-	5	
Q1307	-	-	-	-	-	-	0	-	-	-	-	-	-	5	
Q1308	-	-	-	-	-	-	0	-	-	-	-	-	-	5	

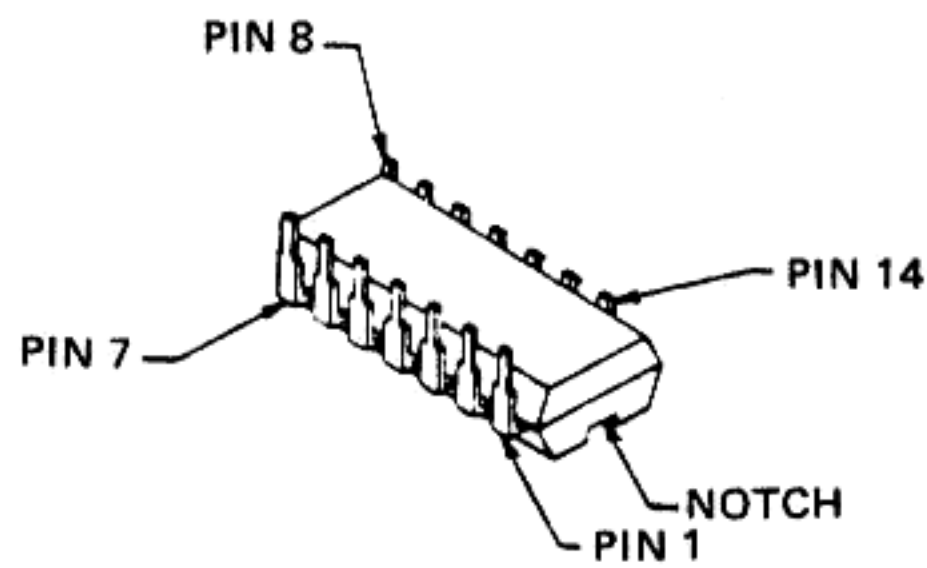

- SN74LS00
- MC14093B
- MC14012B
- MC14001B
- MC14584B
- MC14011B
- MC14013B
- MC14016B

DIAL UNIT PARTS LAYOUT

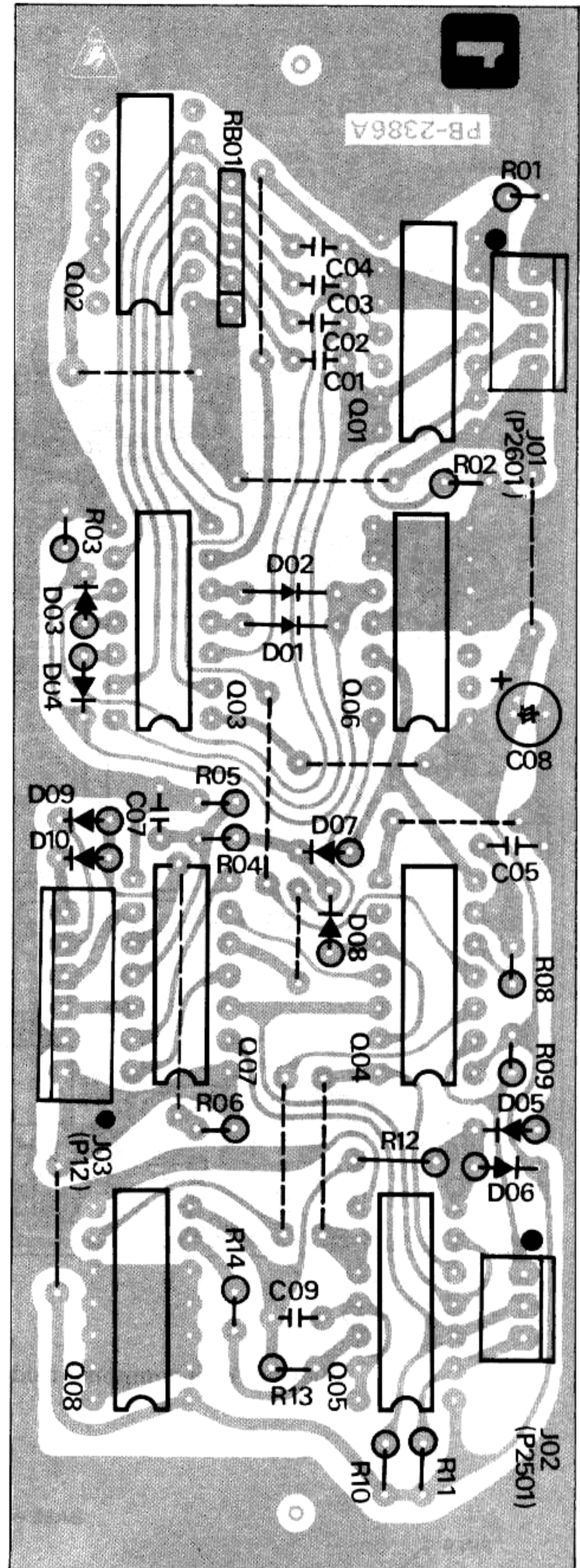
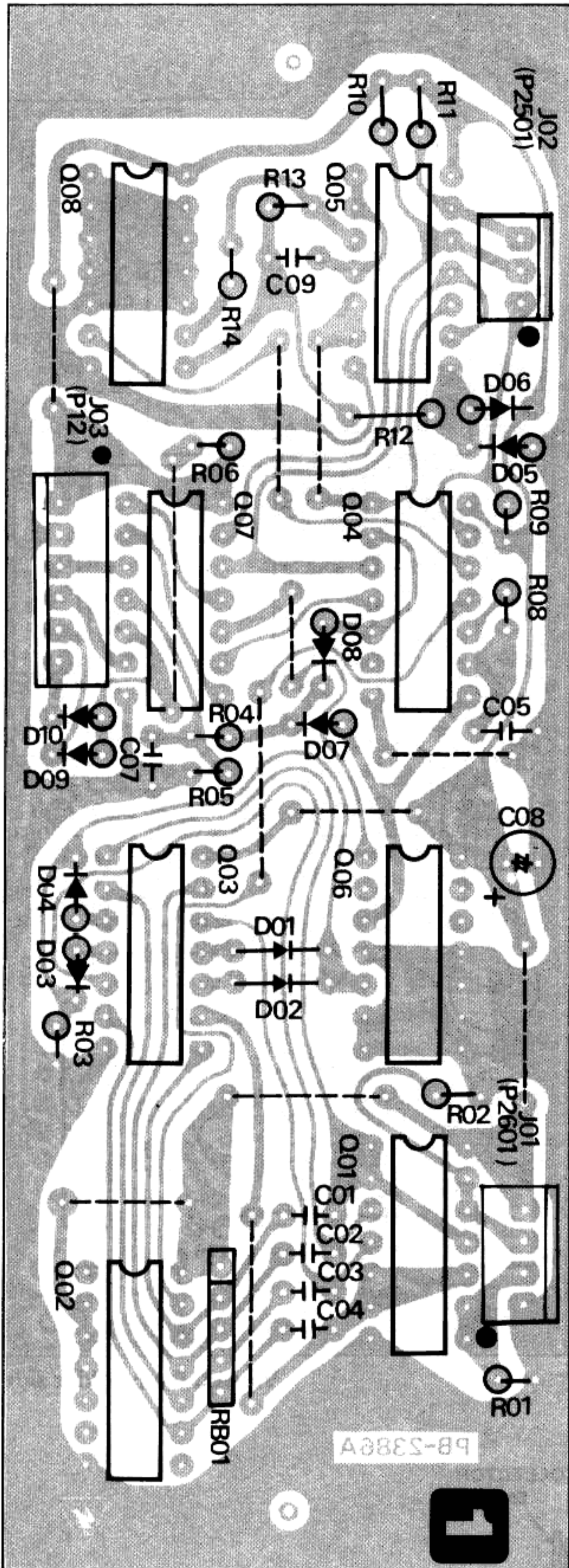

REG UNIT PARTS LAYOUT

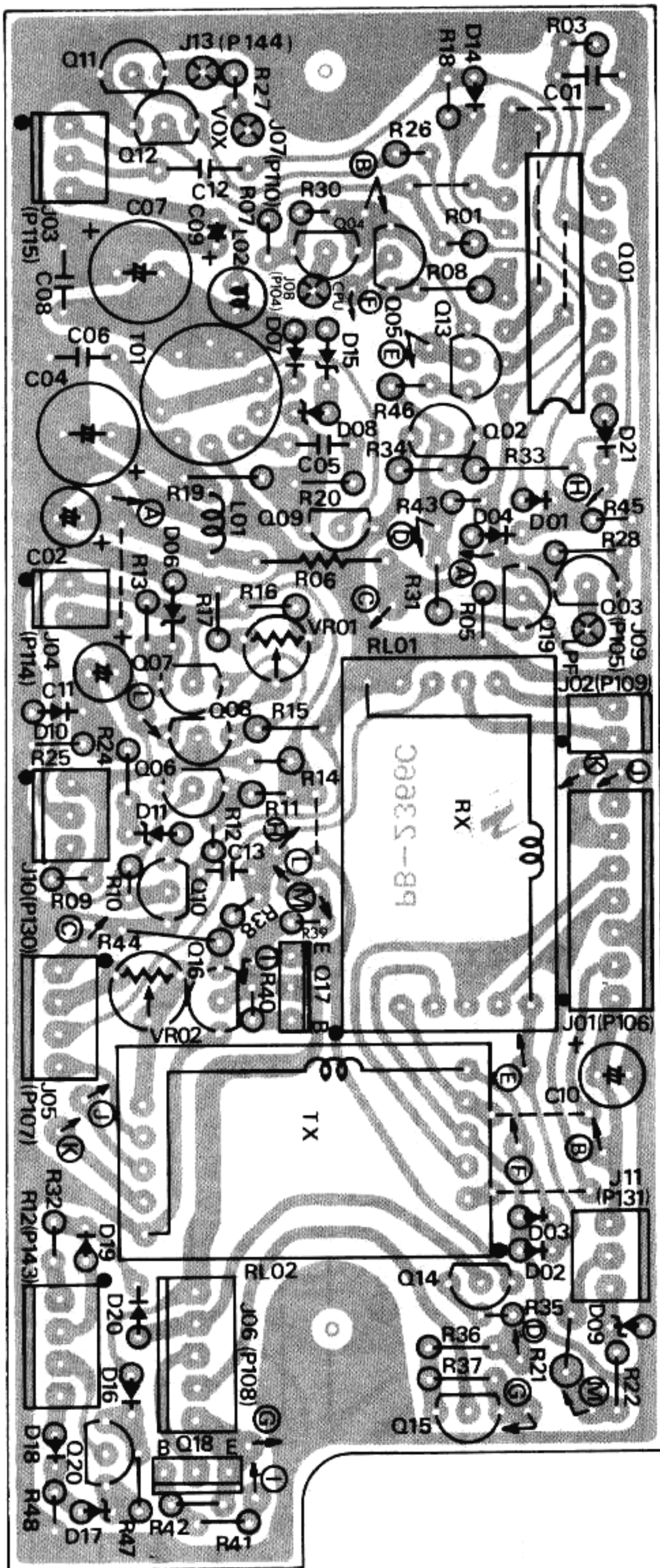

Viewed from component side

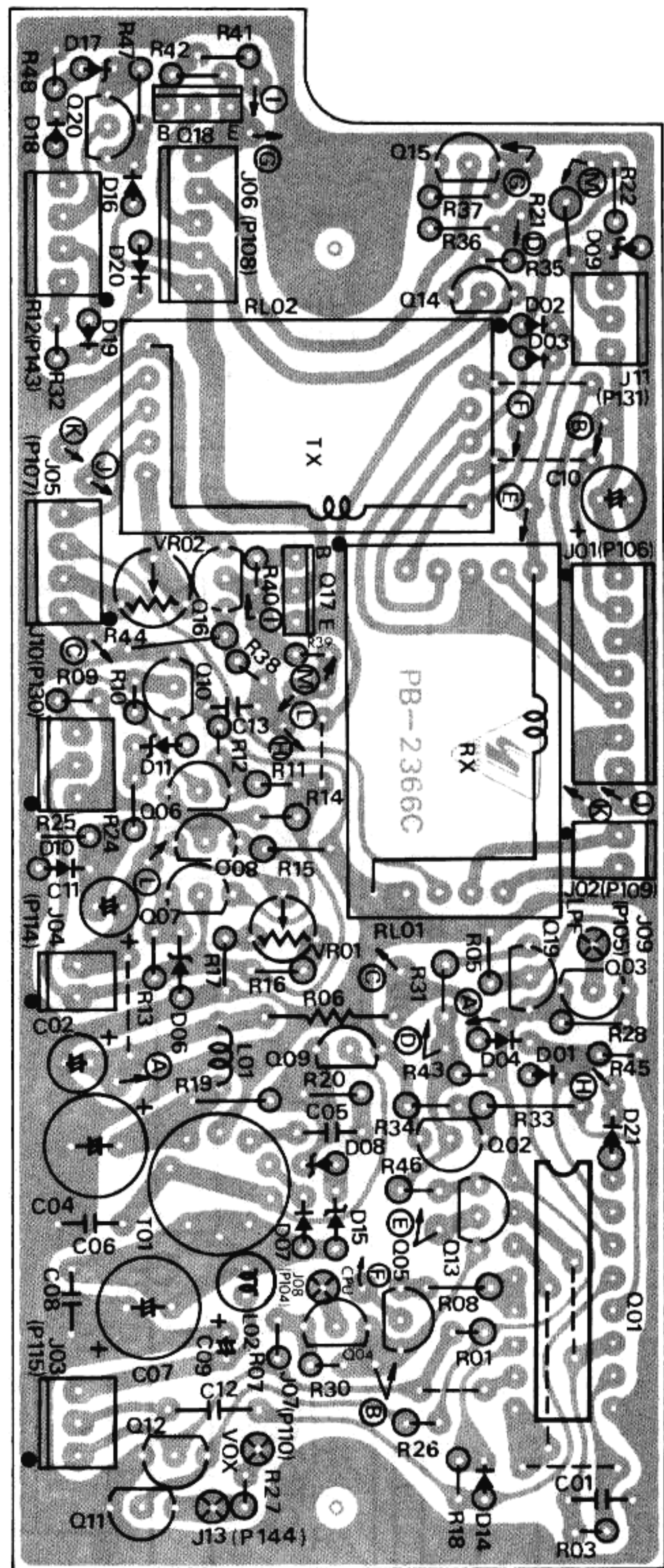

Viewed from solder side

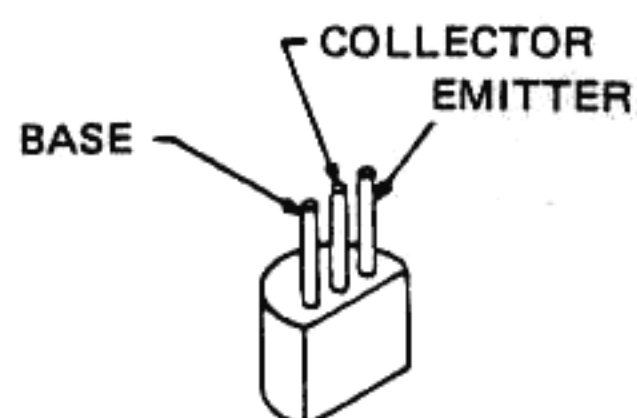
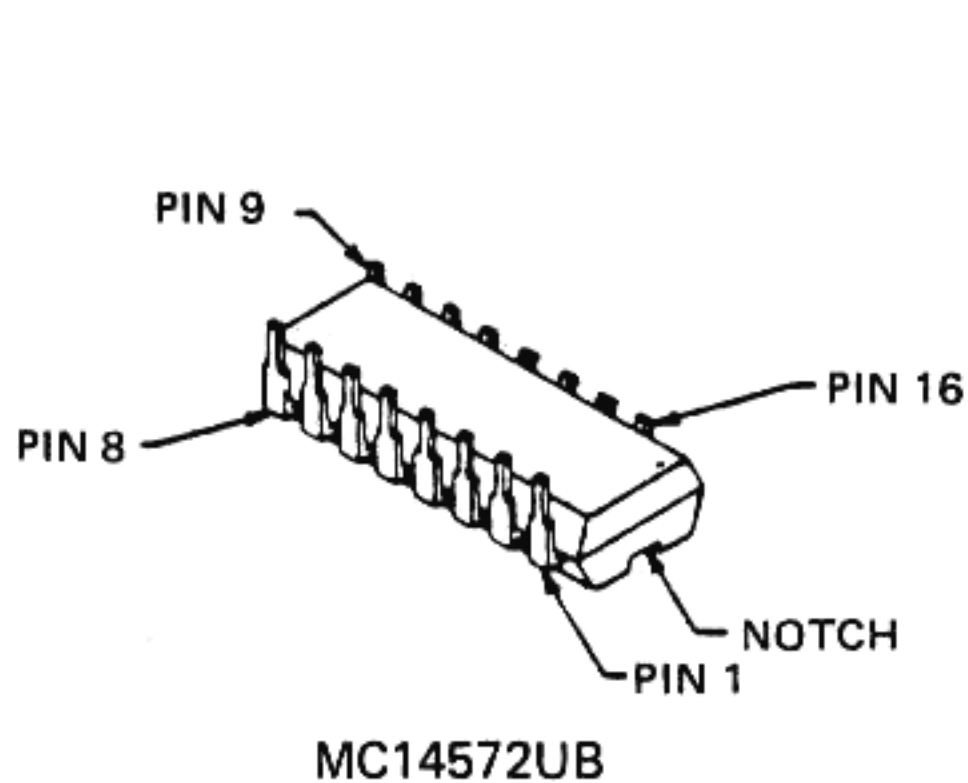

2SC733AQ
2SA950Y
2SC945AQ
2SC1815Y
2SC1815GR
2SC2002L

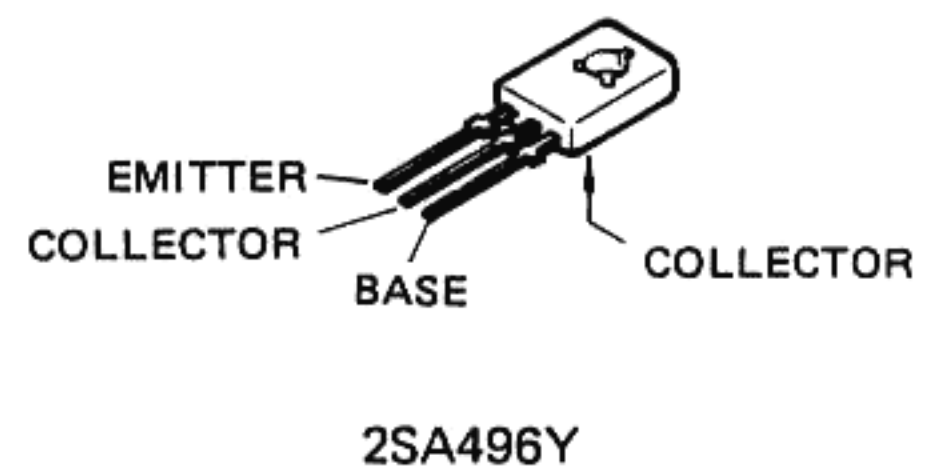

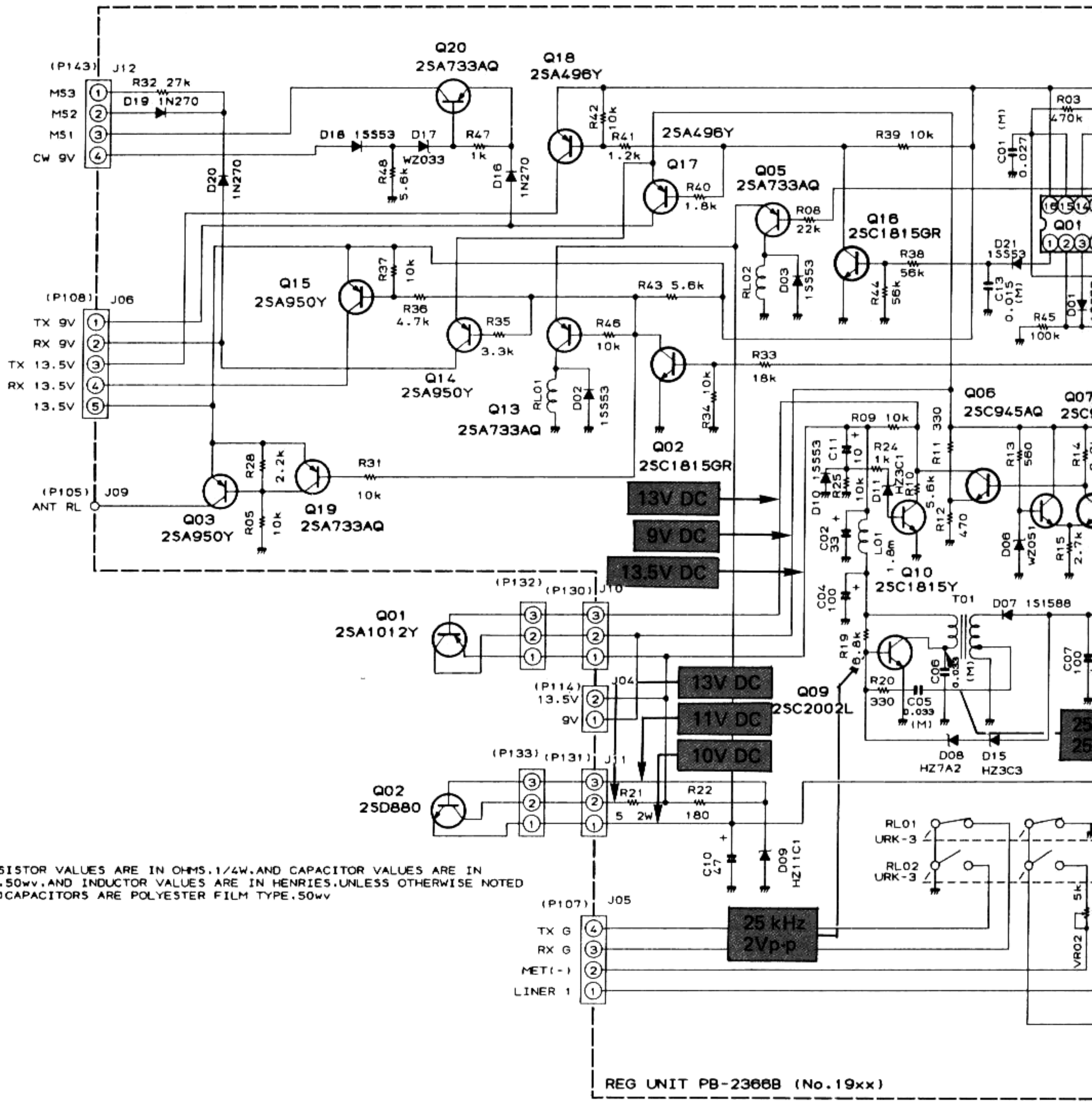

REG UNIT

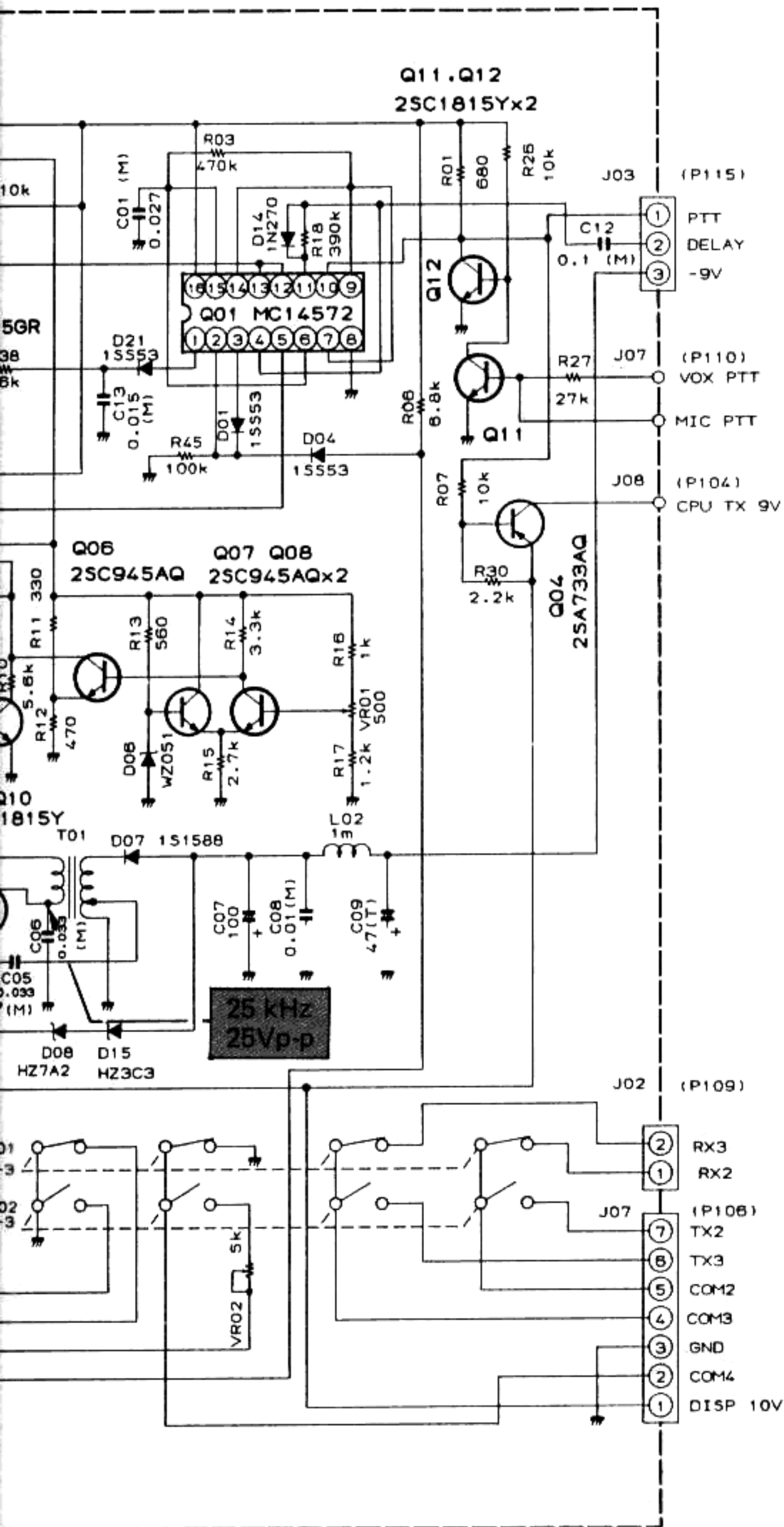

REG UNIT VOLTAGE CHART

(DC VOLTS)

	E (S)		C (D)		B (G1)		(G2)		REMARKS
	R	T	R	T	R	T	R	T	
Q1902	0	0	0	13.5	0.6	0			
Q1903	13.5	13.5	0	13.5	13.5	13			
Q1904	10	10	0	10	11	10			
Q1905	10	10	0	10	13	10			
Q1906	6		13.5		6				
Q1907	5		9		5				
Q1908	5		6		5				
Q1910	0		13.5		0				
Q1911	0		0		0.7				
Q1912	0	0	13.5	0	0	0			
Q1913	10	10	10	0	10	13.5			
Q1914	9	9	9	-8	8	13.5			
Q1915	13.5	13.5	13.5	0	13	13.5			
Q1916	0	0	13.5	0	0	0.7			
Q1917	9	9	0	9	13.5	8			
Q1918	13.5	13.5	0	13.5	13.5	13			
Q1919	13.5	13.5	13.5	13	13	13.5			
Q1920	0	9	0	9	-0.5	8			
	0	7	-8	9	0	8			MONI → ON

REG UNIT VOLTAGE CHART

(DC VOLTS)

	1	2	3	4	5	6	7	8	9	10	11	12	13	14	15	16	REMARKS	
	Q1901	0	13	13.5	0	13.5	0	0	0	0	13.5	0	13.5	13.5	0	0		13.5
	13.5	0	0	0	0	13.2	13.5	0	13.5	0	13.5	0	0	13.5	13.2	13.5	TX	→ 2

CONTROL UNIT

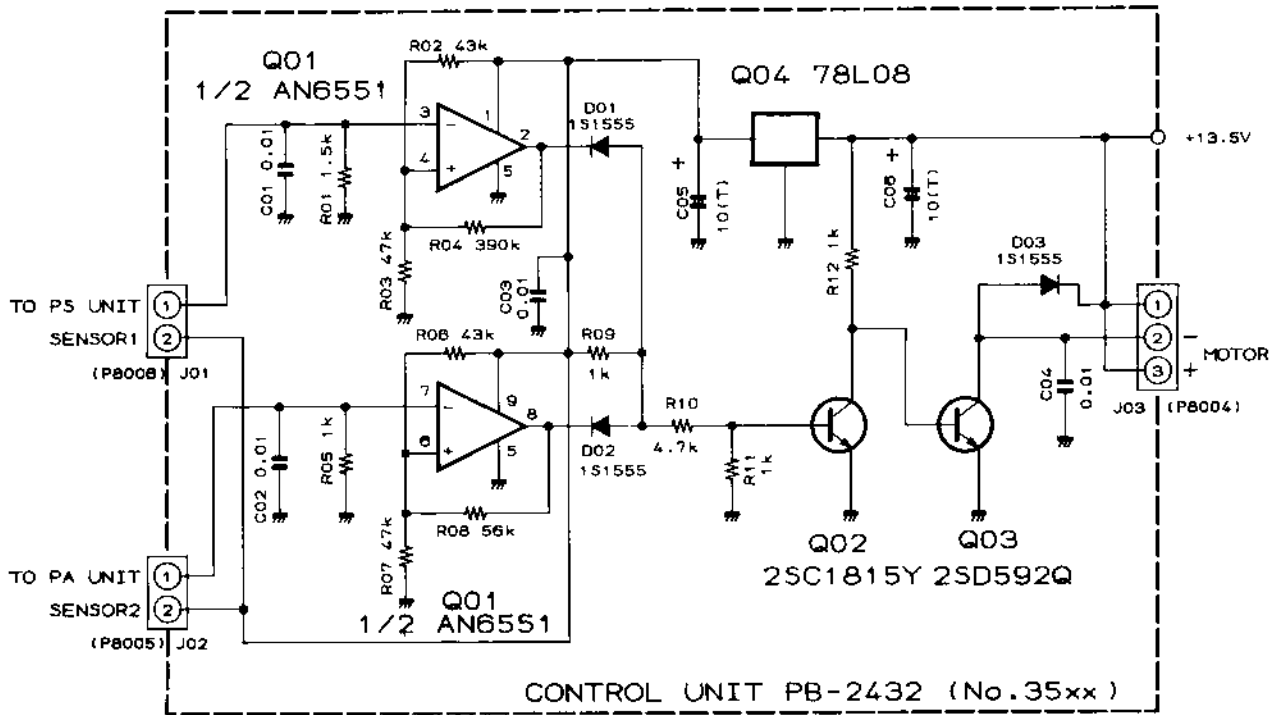

RESISTOR VALUES ARE IN OHMS, AND CAPACITOR VALUES ARE IN μ F, 50V,
UNLESS OTHERWISE NOTED
(T) CAPACITORS ARE TANTALUM, 16V

**CONTROL UNIT VOLTAGE CHART
(DC VOLTS)**

	1	2	3	4	5	6	7	8	9	REMARKS
Q3501	8	-	-	4.4	0	4.6	-	-	8	

**CONTROL UNIT VOLTAGE CHART
(DC VOLTS)**

	E (S)		C (D)		B (G1)		(G2)		REMARKS
	R	T	R	T	R	T	R	T	
Q3502	0		0		0.7				MOTOR OFF
Q3503	0		13.5		0				
Q3504	IN 13.5		COM 0		OUT 8				

CONTROL UNIT PARTS LAYOUT

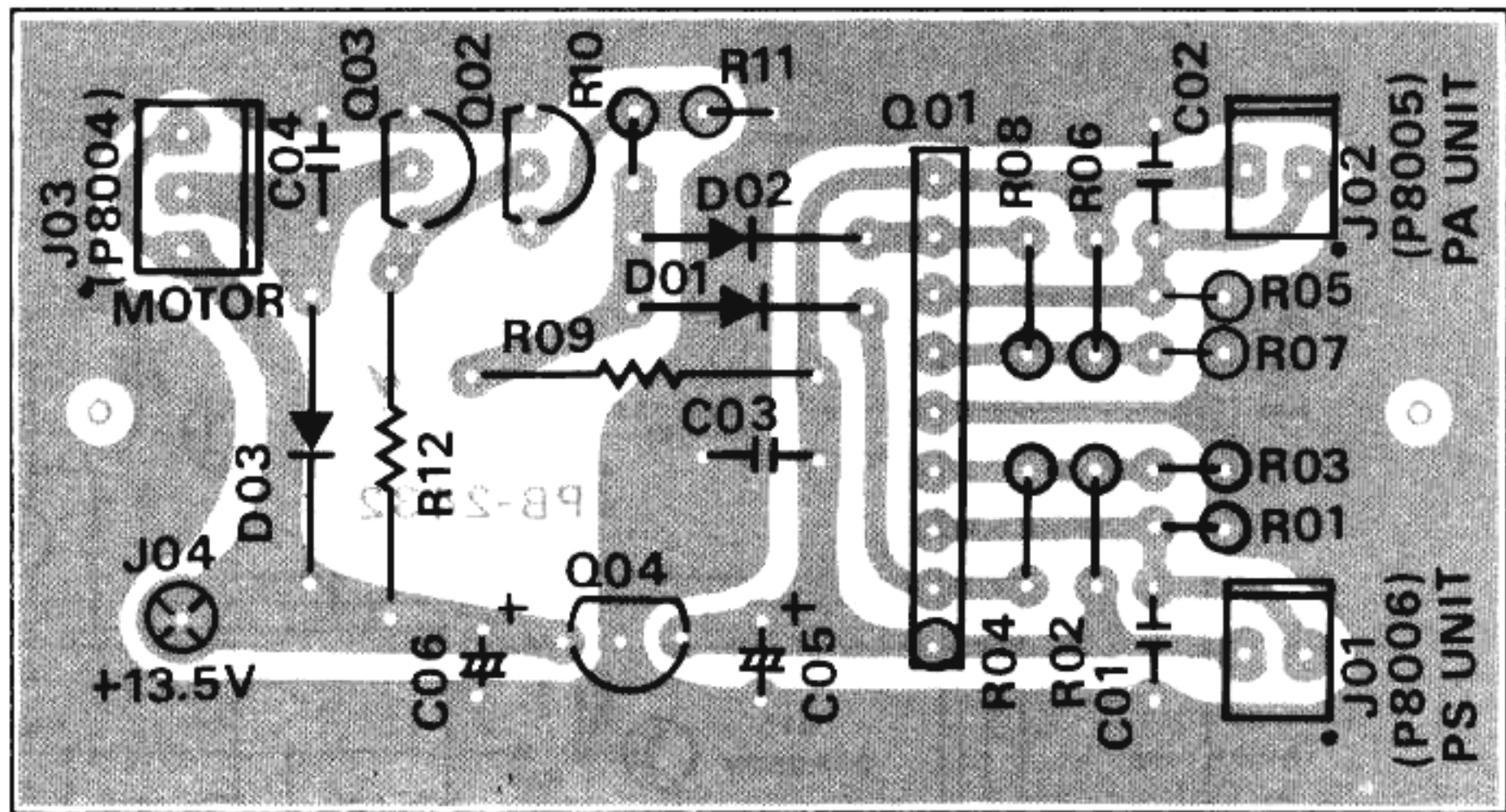

Viewed from component side

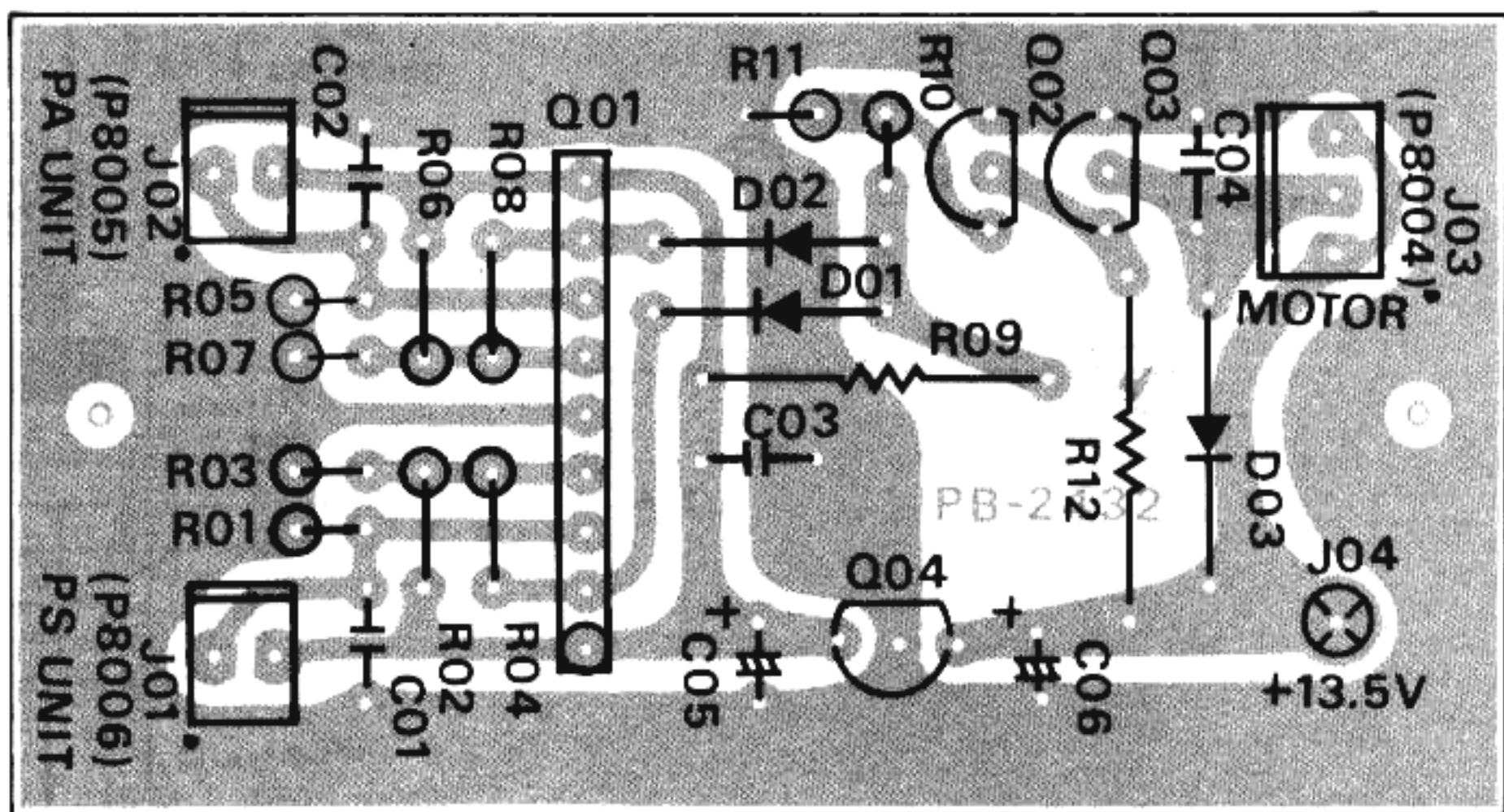

Viewed from solder side

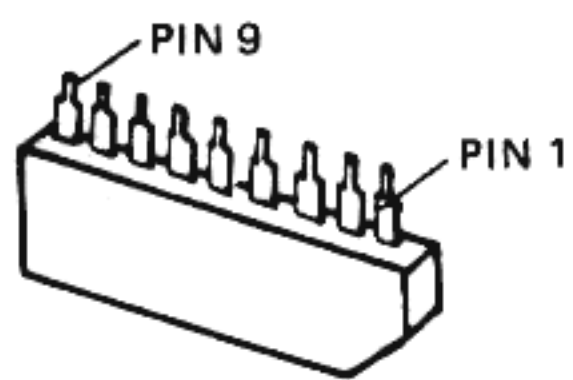

AN6551

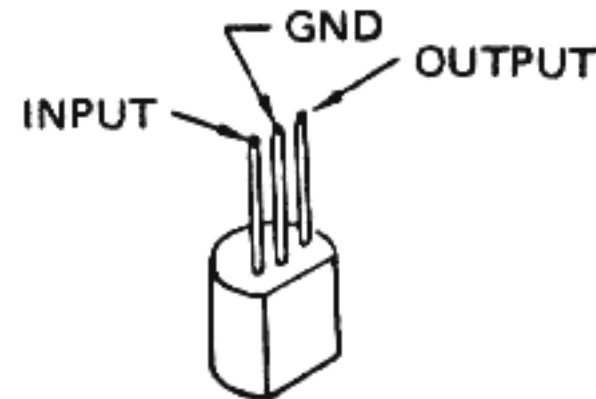

NJM78L08

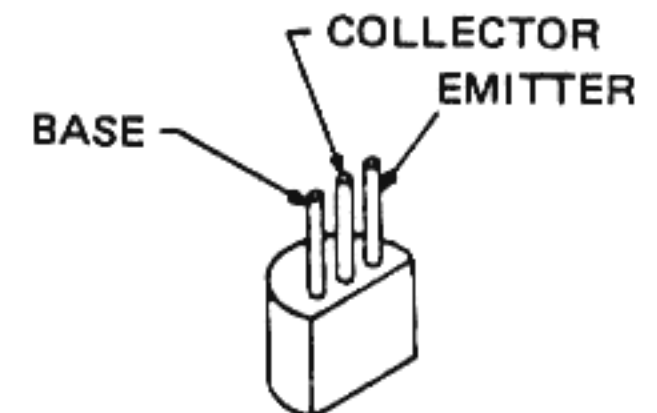

2SC1815Y
2SD592Q

KEY MATRIX UNIT PARTS LAYOUT

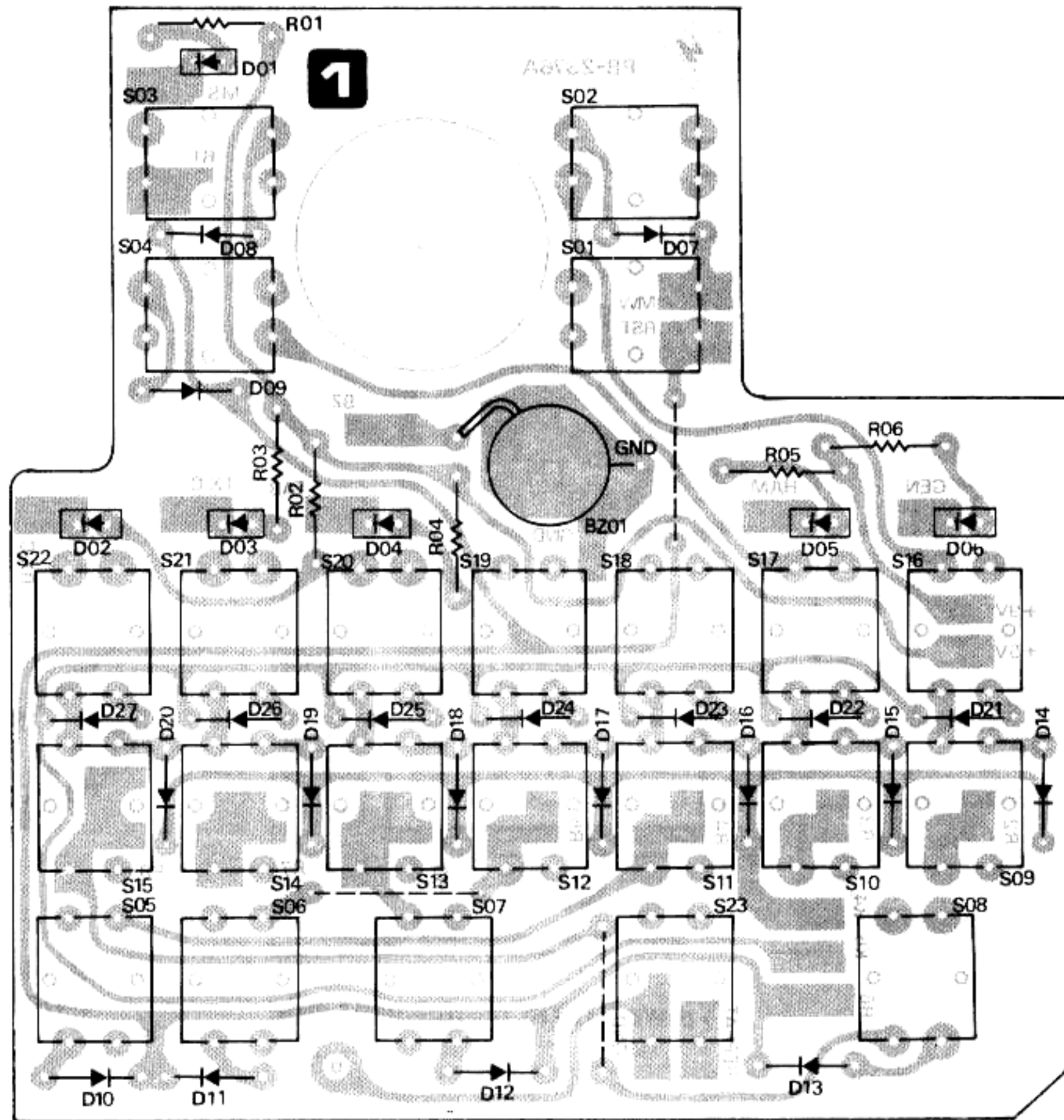

Viewed from component side

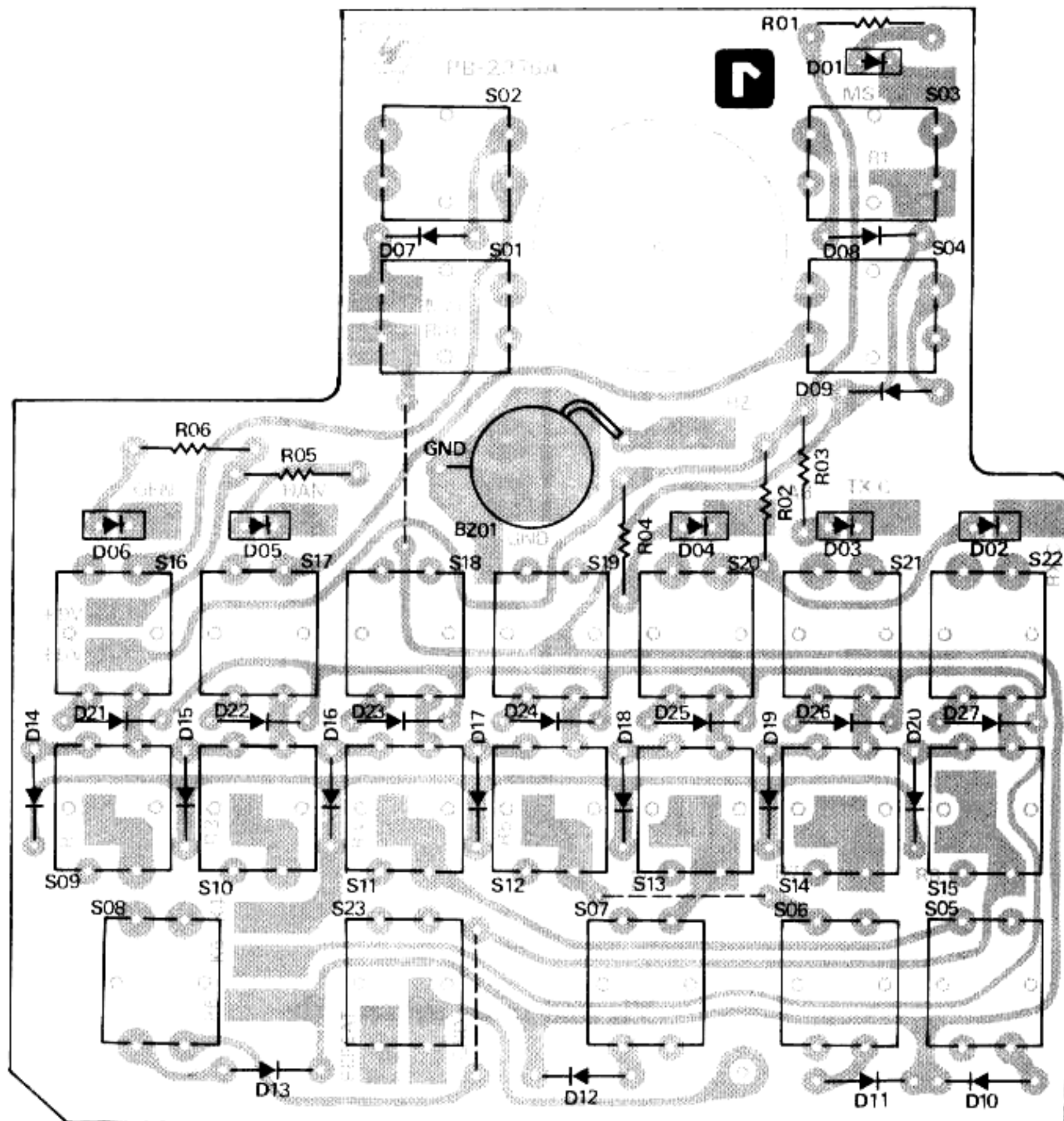

Viewed from solder side

KEY MATRIX UNIT

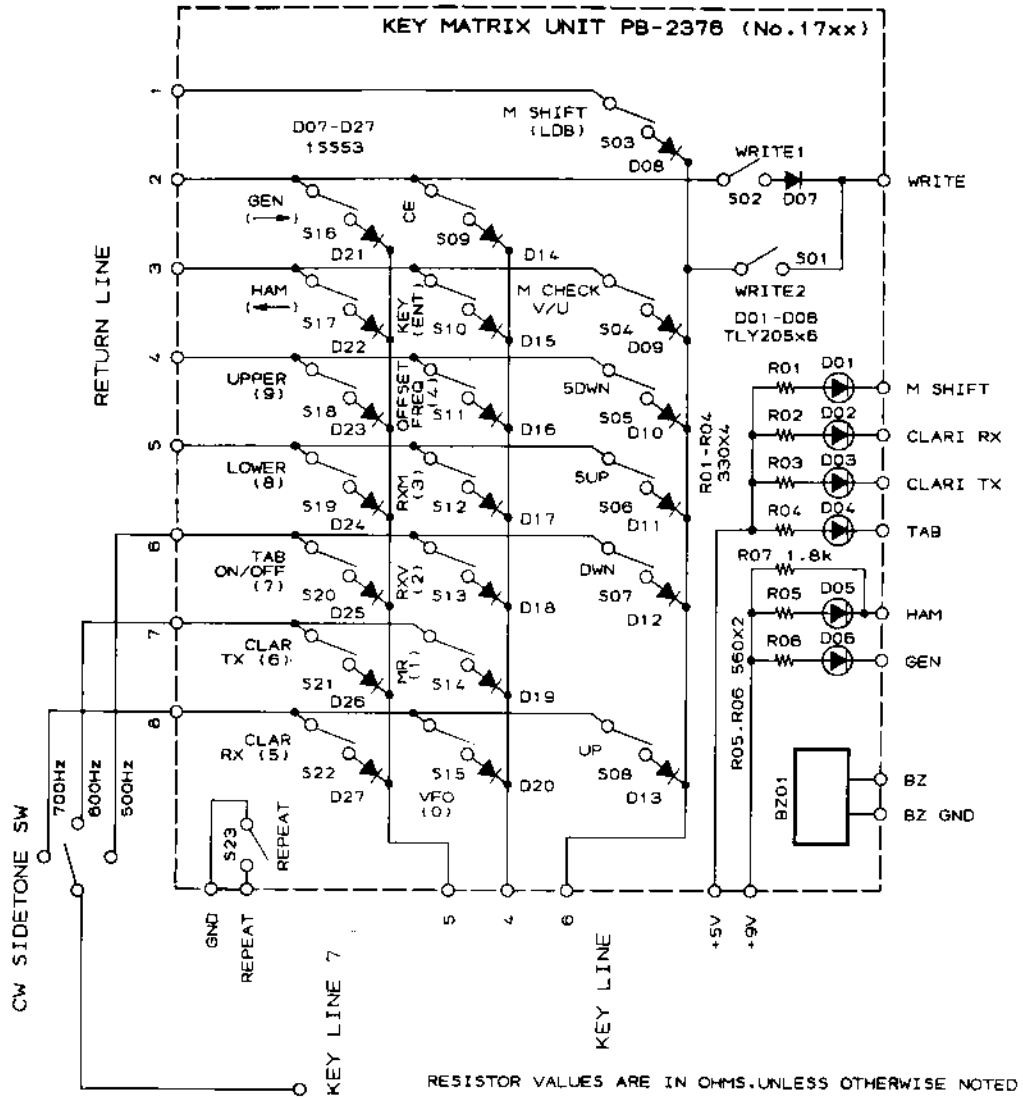

DISPLAY UNIT A PARTS LAYOUT

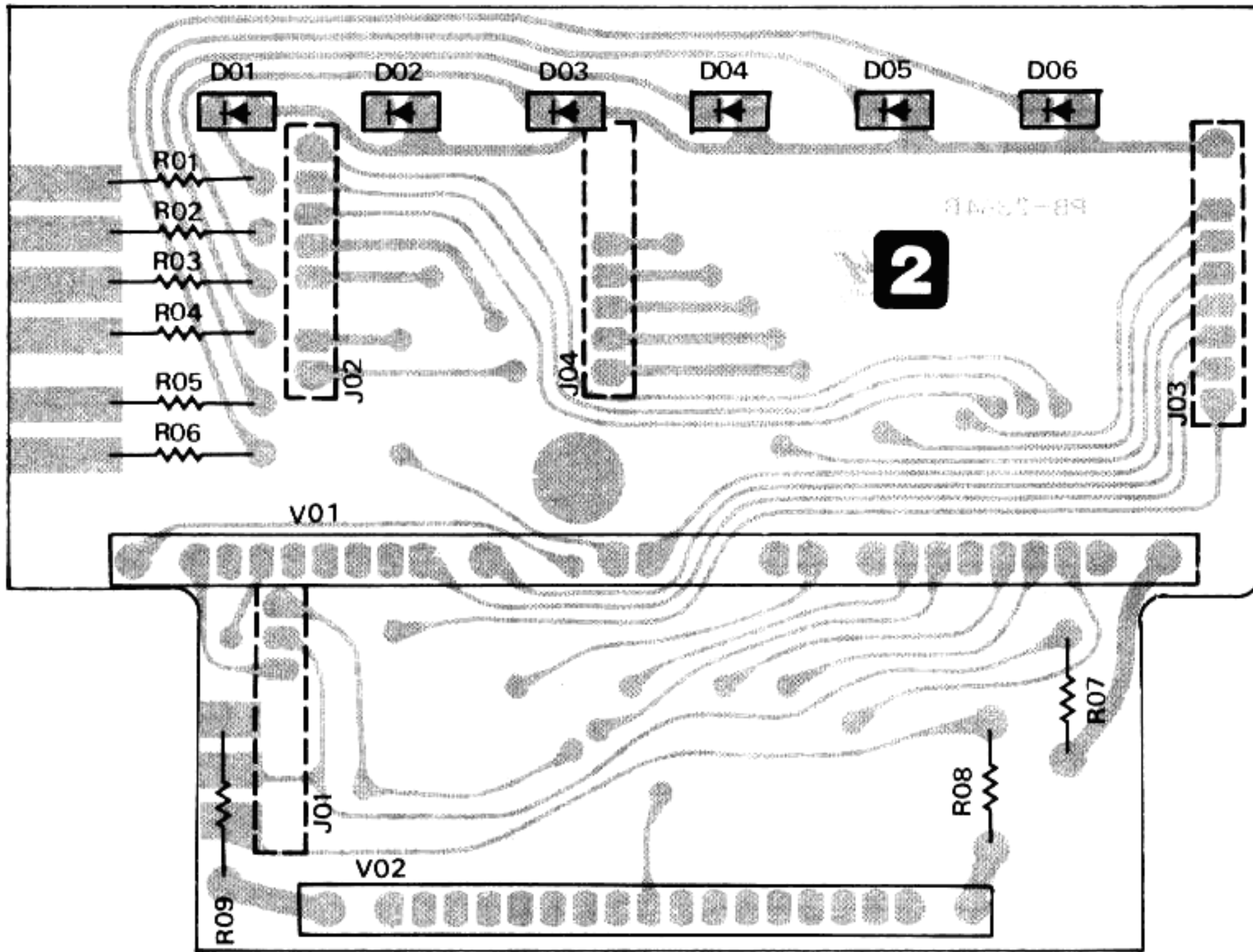

Viewed from component side

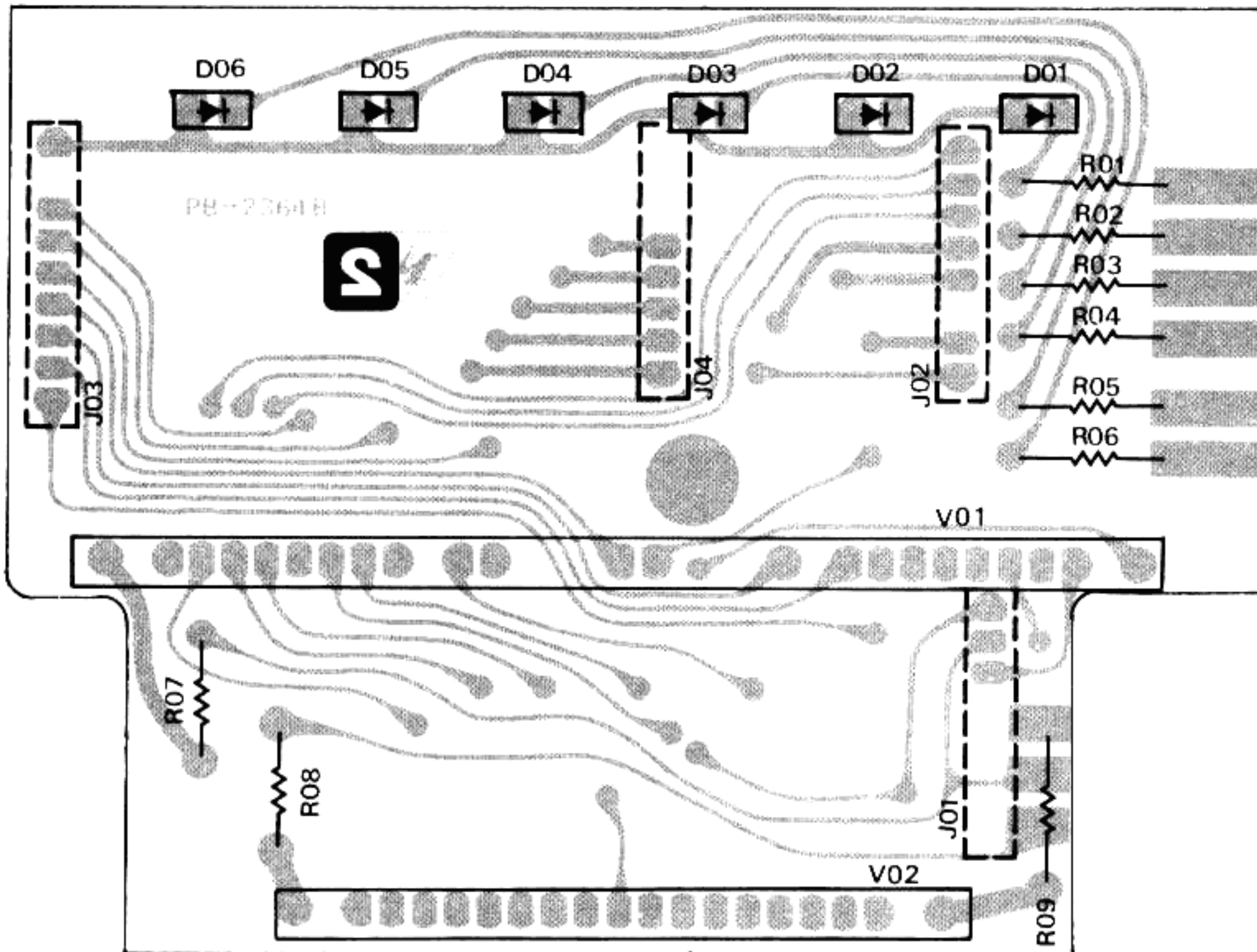

Viewed from solder side

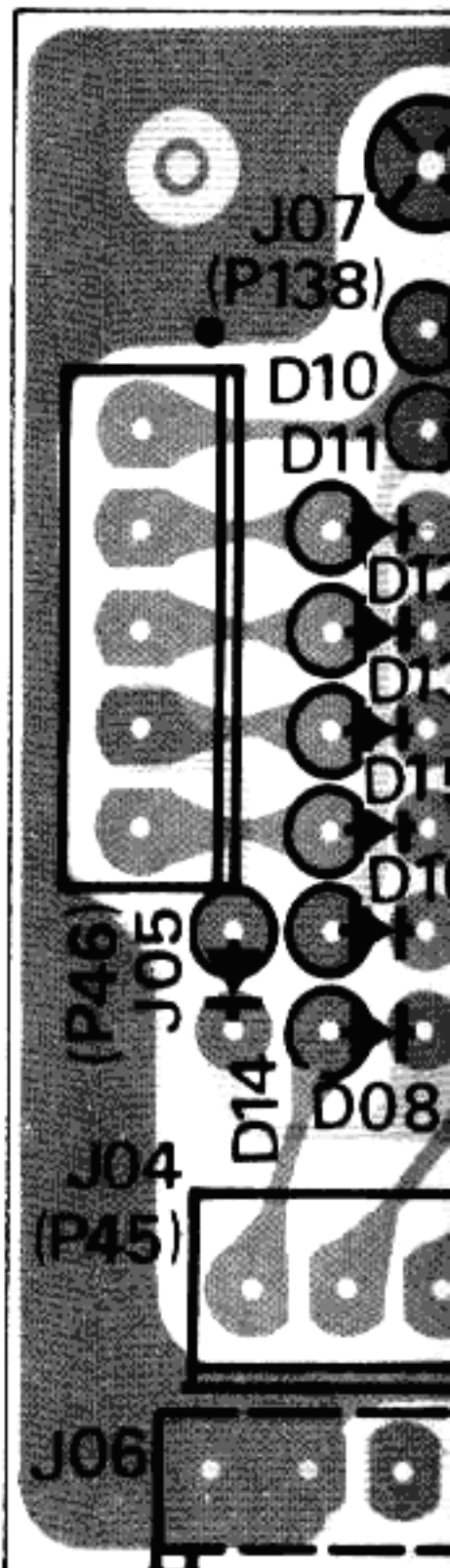
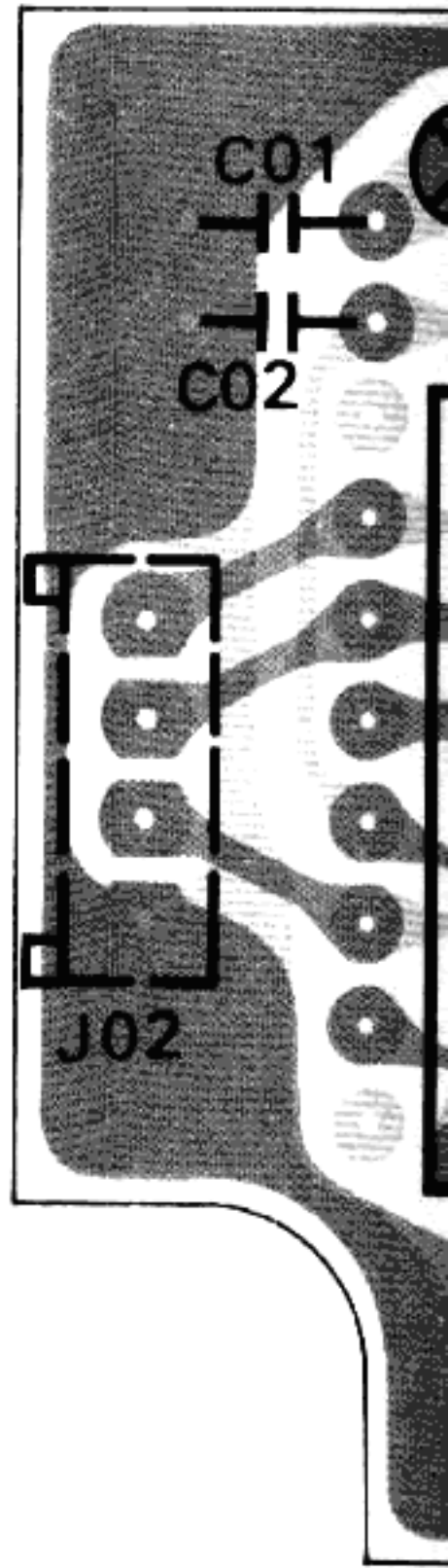

DISPLAY UNIT C PARTS LAYOUT

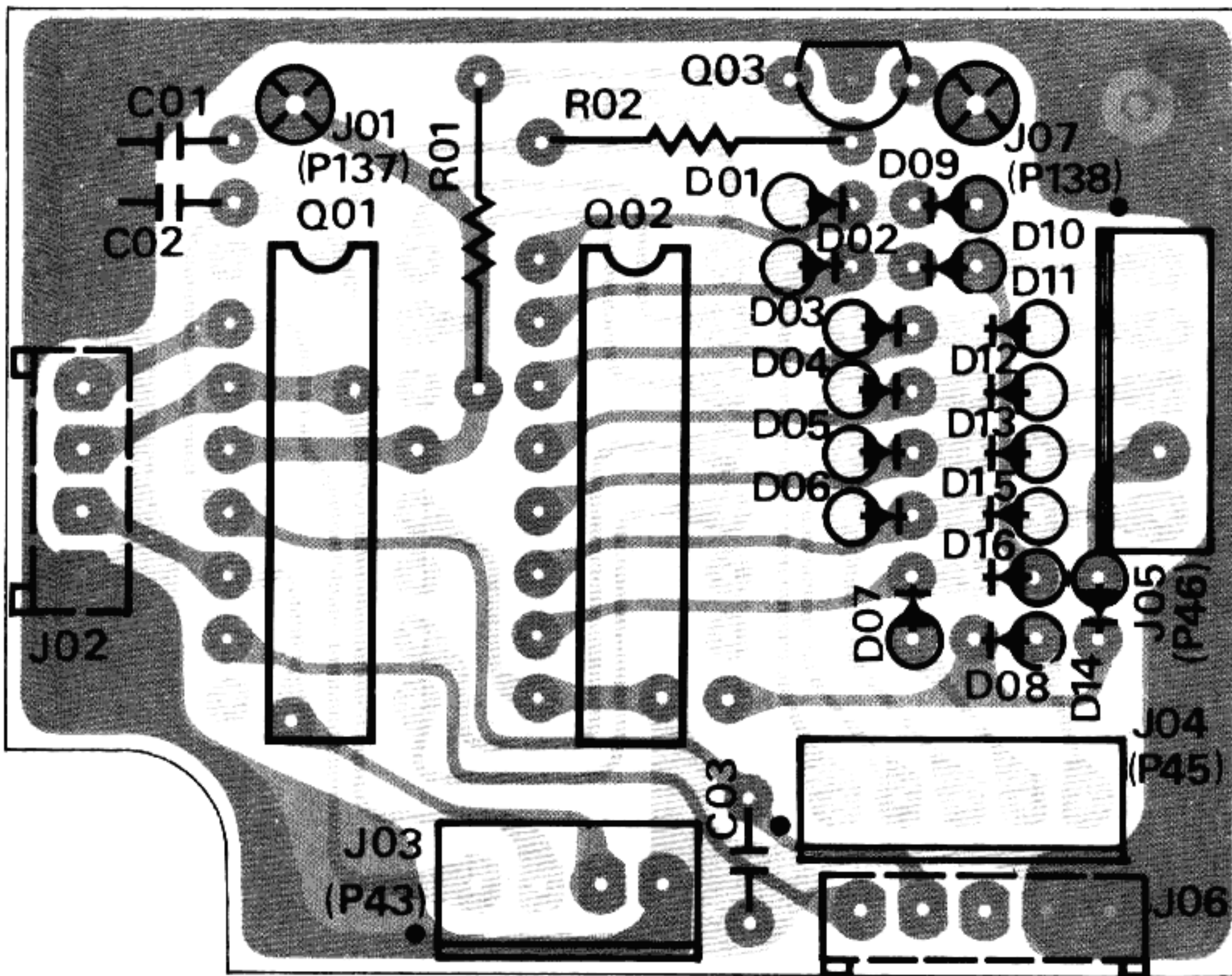

Viewed from component side

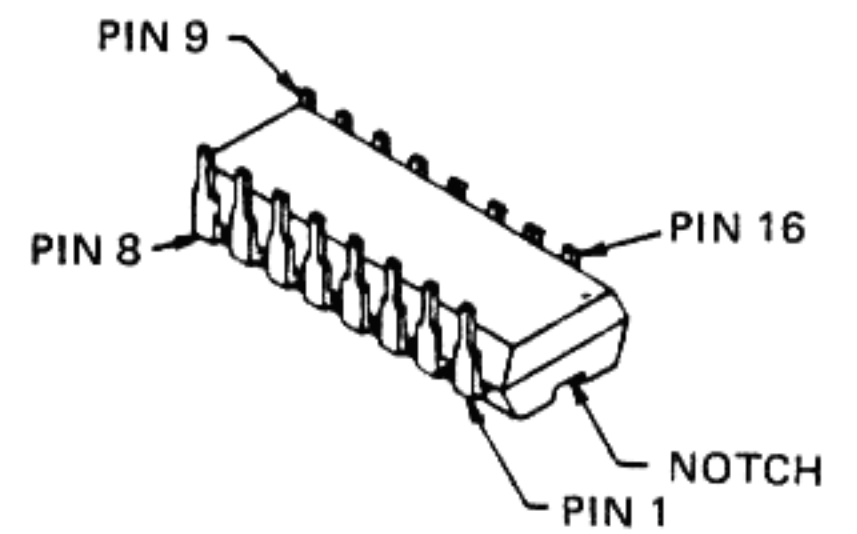

SN74LS75N
SN74LS145N

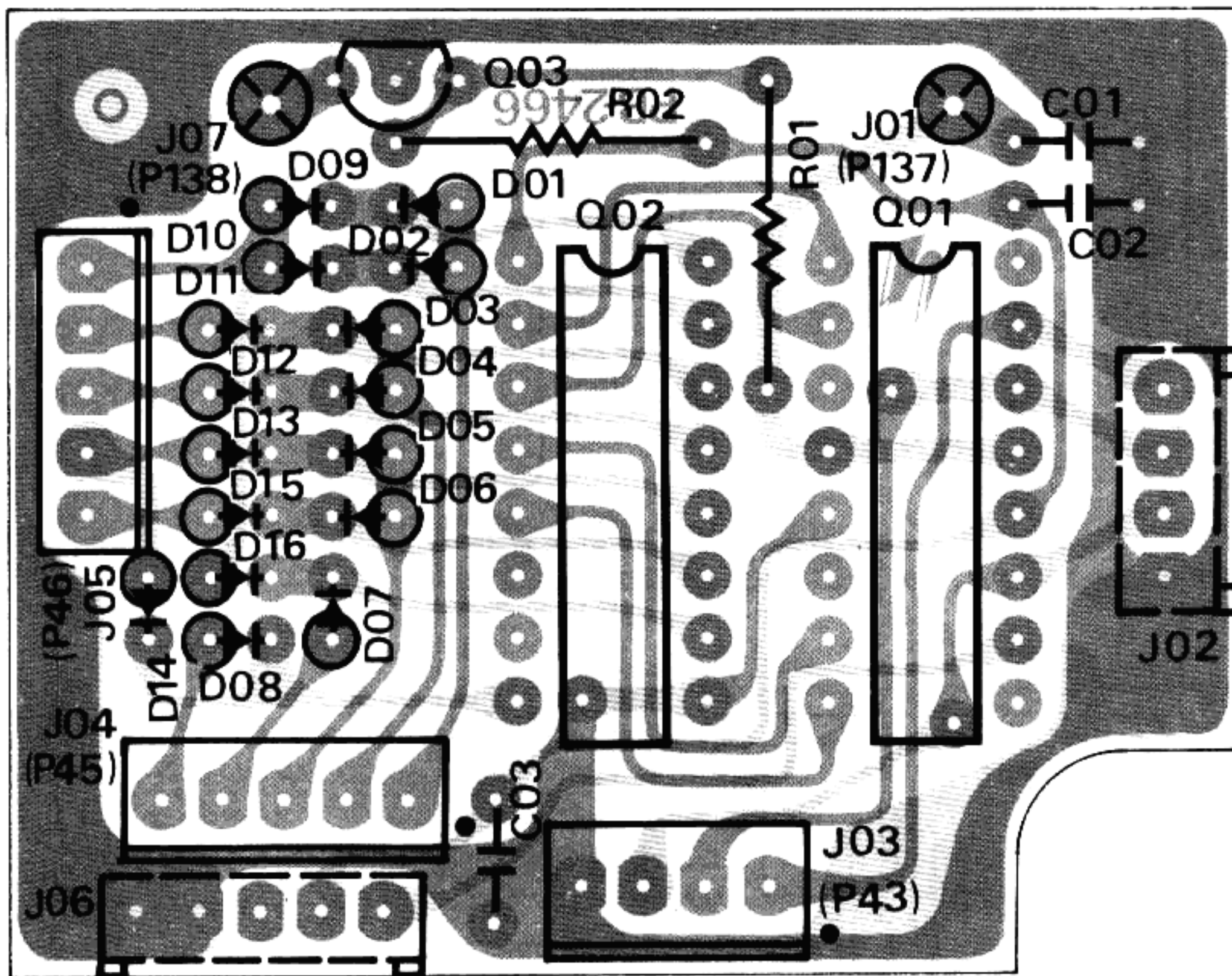

Viewed from solder side

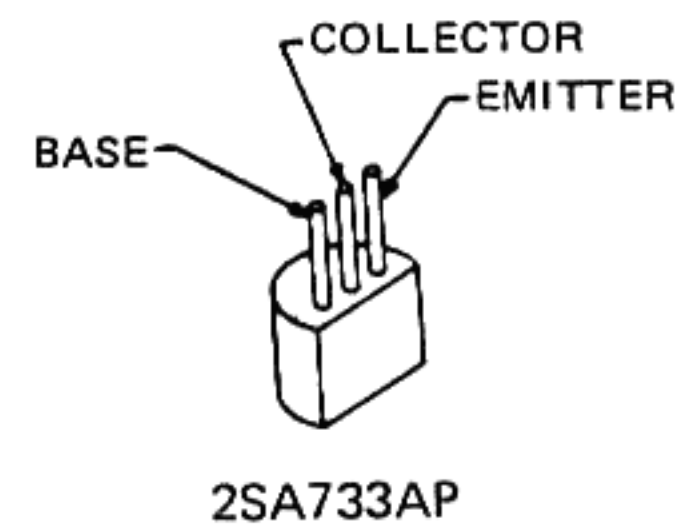

2SA733AP

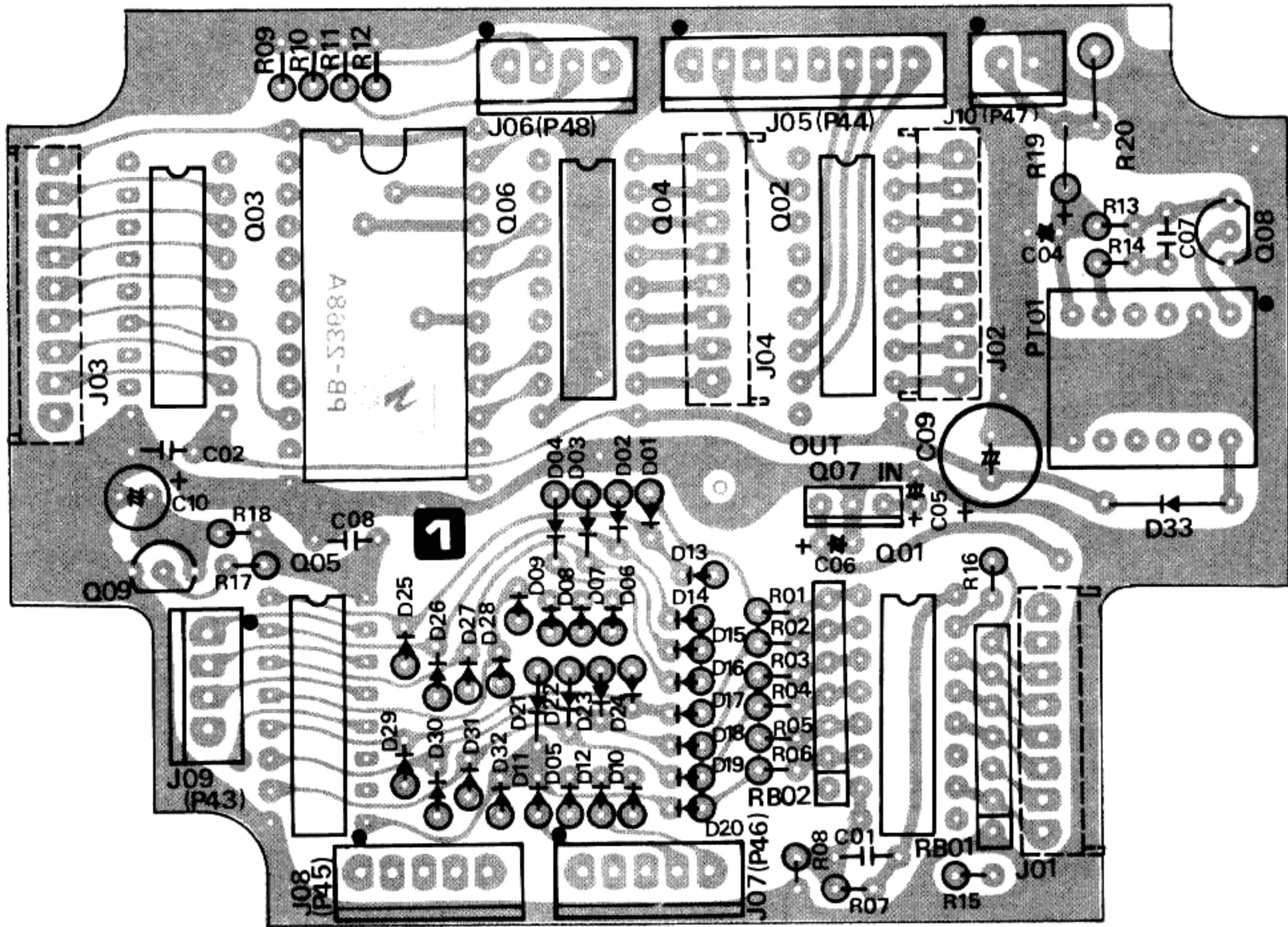

Viewed from component side

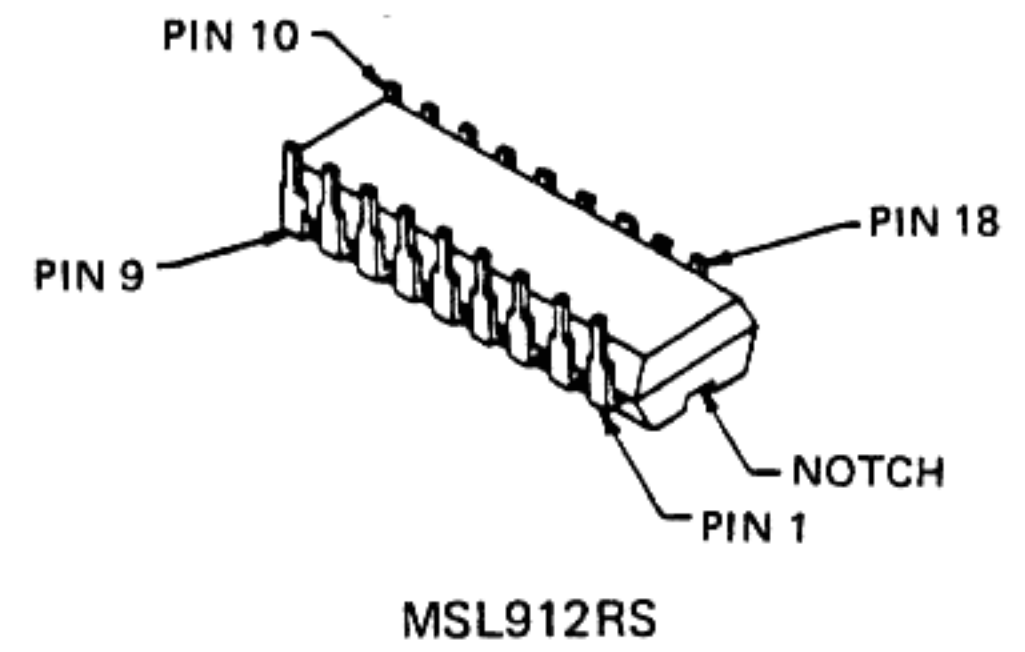
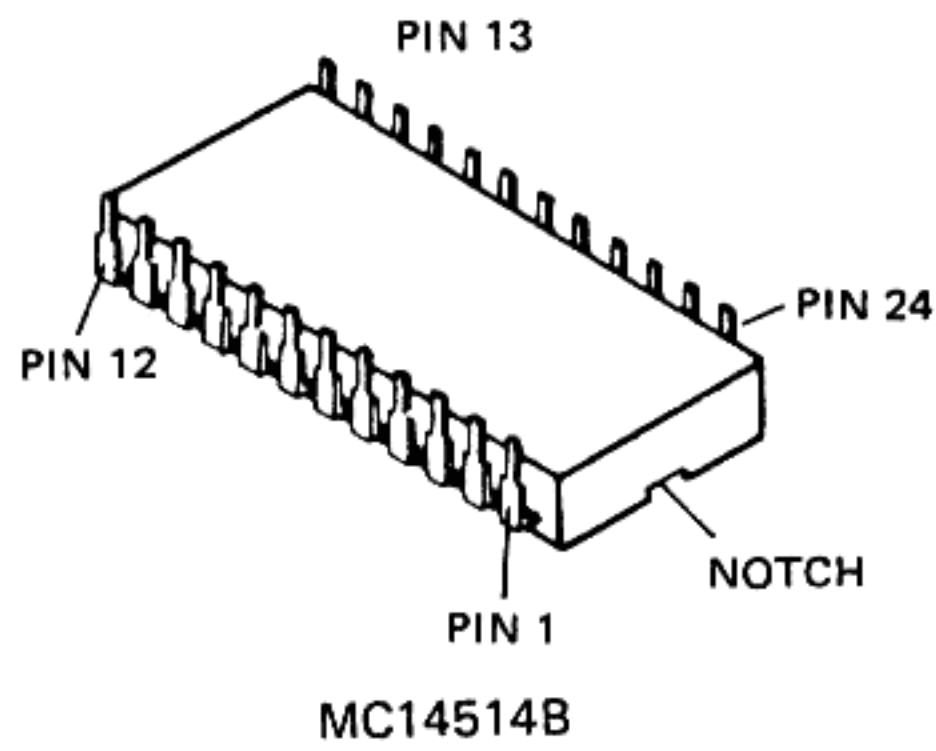

UNIT B PARTS LAYOUT

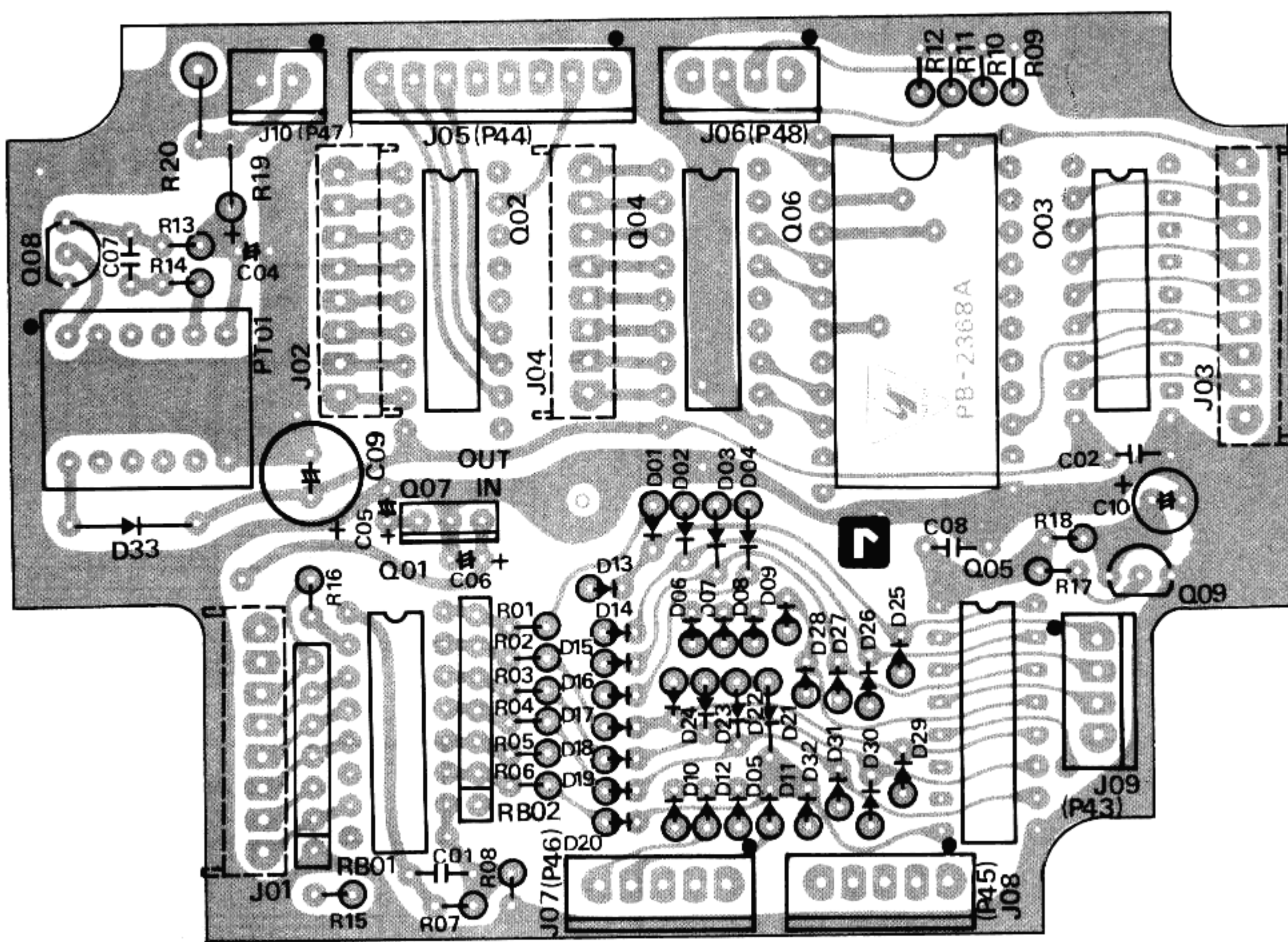
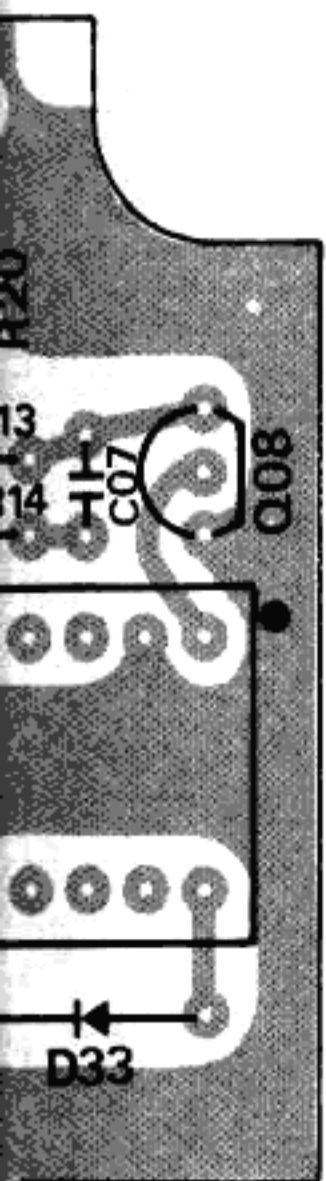

Component side

Viewed from solder side

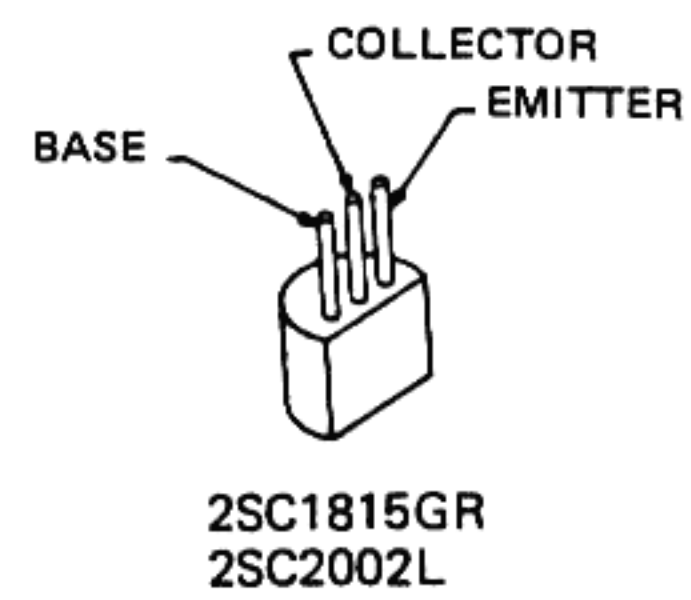
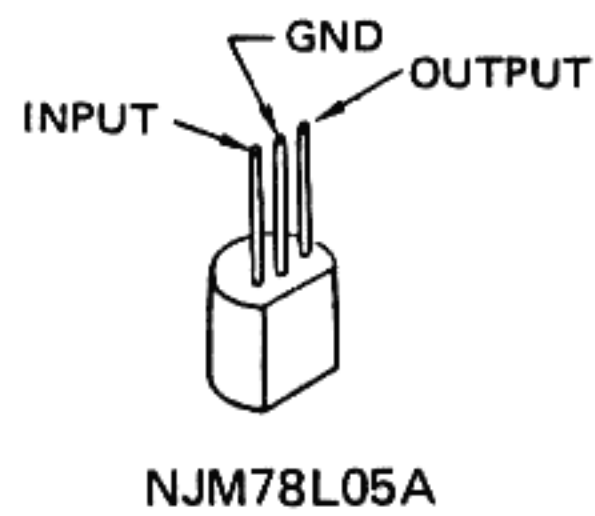
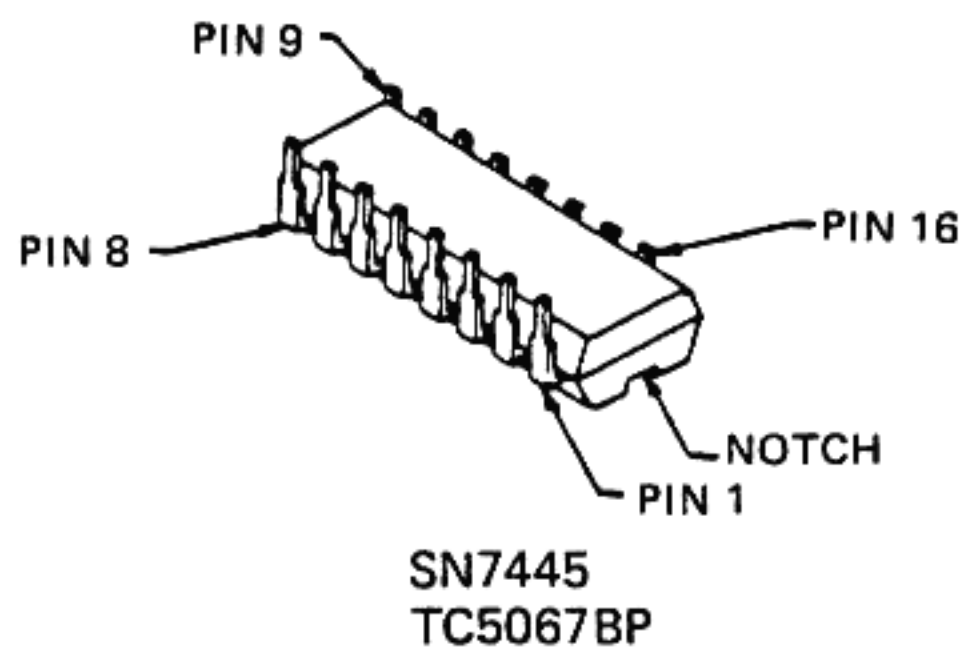
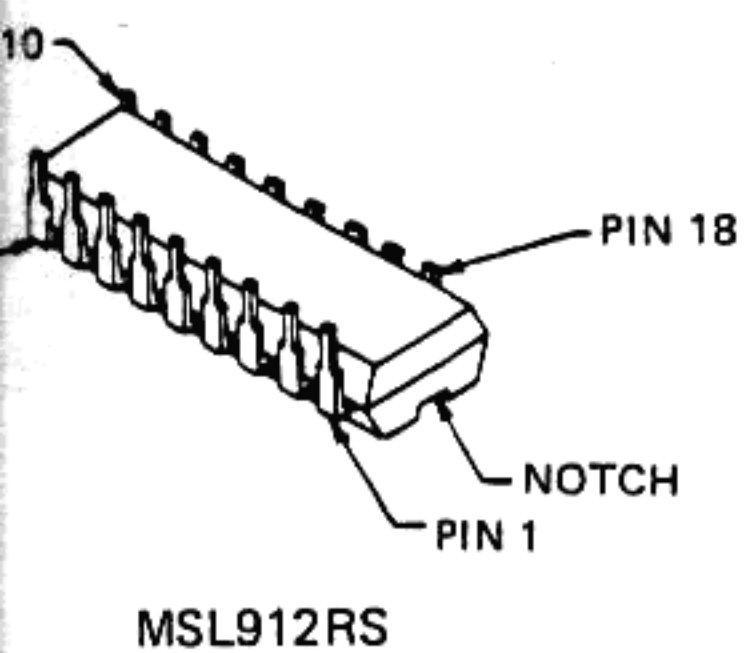

DISPLAY UNIT

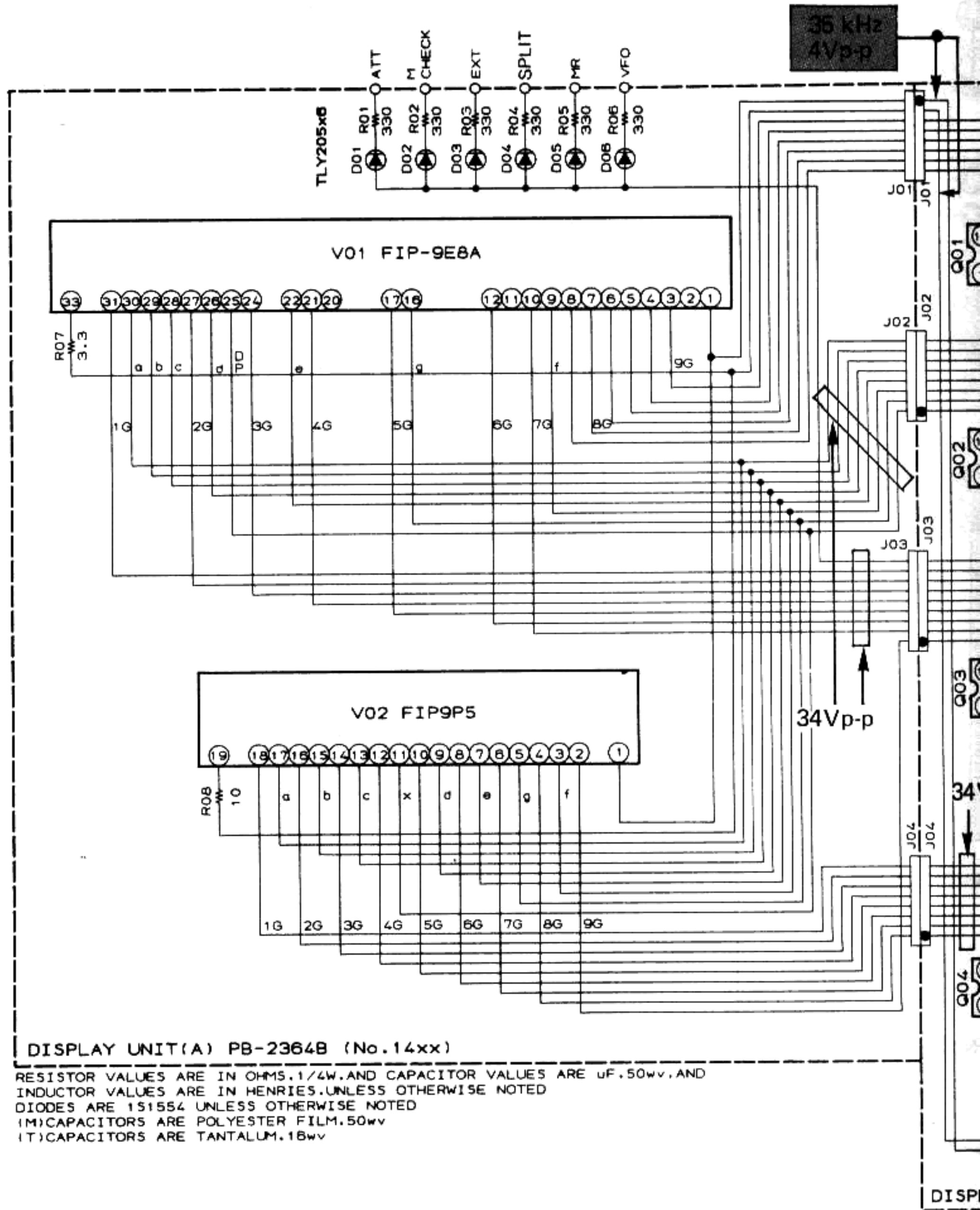

DISPLAY UNIT (B) VOLTAGE CHART

(DC VOLTS)

	E (S)		C (D)		B (G1)		(G2)		REMARKS
	R	T	R	T	R	T	R	T	
Q1619	0		5		5				
Q1607	IN 9		COM 0		OUT 5				

DISPLAY UNIT (B) VOLTA

	1	2	3	4	5	6	7	8	9	10	11	12	13
Q1601	-	-	-	-	-	-	22	22	-	-	-	-	-
Q1602	-	-	-	-	-	-	-	-	0	34	-	-	-
Q1603	-	-	-	-	-	-	-	-	0	34	-	-	-
Q1604	-	-	-	-	-	-	-	-	0	34	-	-	-
Q1605	-	-	-	-	-	-	-	0	-	-	-	0	-
Q3701	-	-	-	-	5	-	0	-	-	-	-	u	-
Q3702	-	-	-	-	-	-	-	0	-	-	-	-	-

DISPLAY UNIT

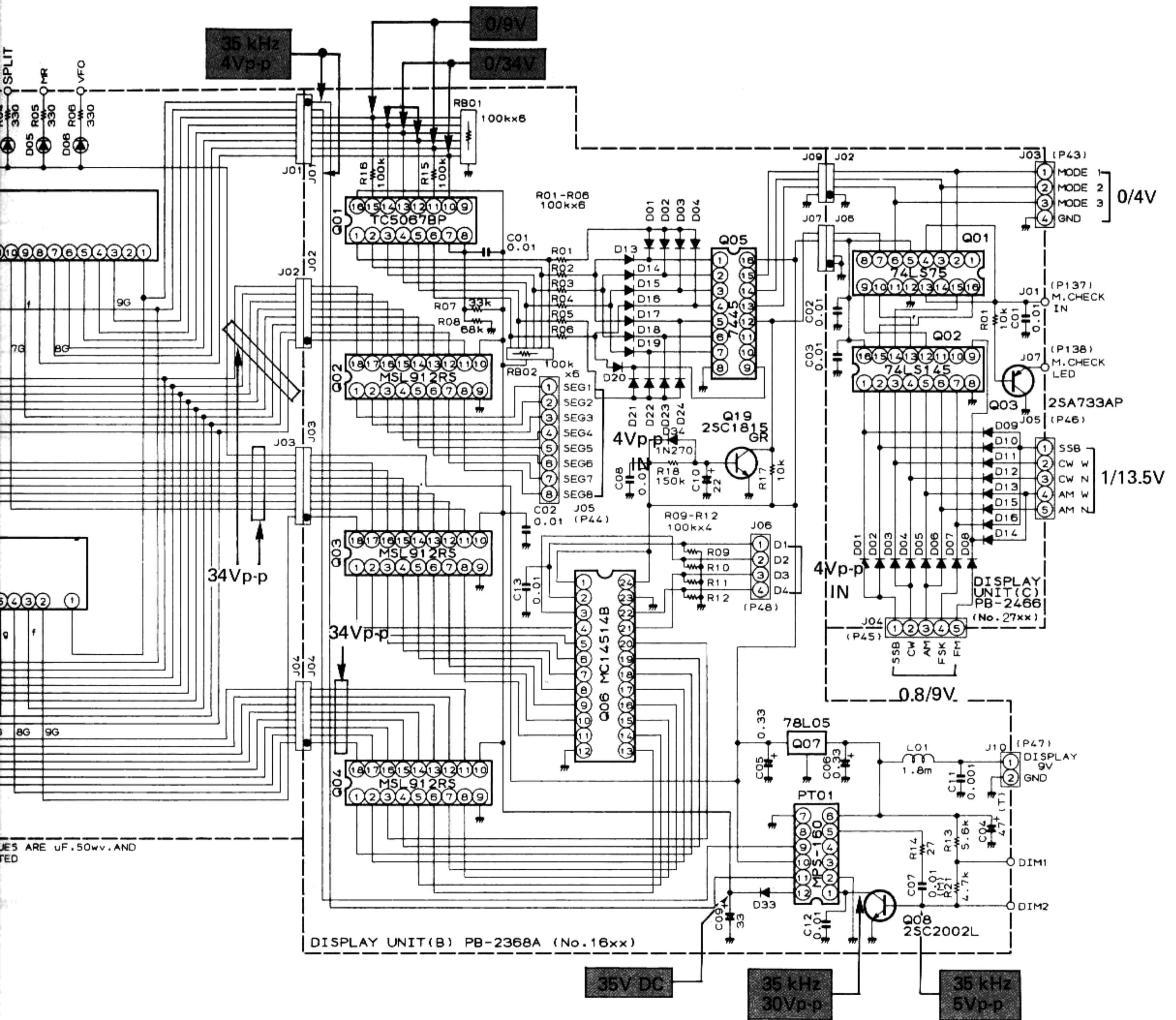

DISPLAY UNIT (B) VOLTAGE CHART
(DC VOLTS)

	1	2	3	4	5	6	7	8	9	10	11	12	13	14	15	16	17	18	REMARKS
601	-	-	-	-	-	22	22	-	-	-	-	-	-	-	-	34	-	-	
602	-	-	-	-	-	-	0	34	-	-	-	-	-	-	-	-	-	-	
603	-	-	-	-	-	-	0	34	-	-	-	-	-	-	-	-	-	-	
604	-	-	-	-	-	-	0	34	-	-	-	-	-	-	-	-	-	-	
605	-	-	-	-	-	0	-	-	0	-	-	-	-	-	-	5	-	-	
701	-	-	-	5	0	-	-	-	0	-	-	-	-	-	-	-	-	-	
702	-	-	-	-	0	-	-	-	-	-	-	-	-	-	-	5	-	-	

DISPLAY UNIT (C) VOLTAGE CHART
(DC VOLTS)

	E (S)		C (D)		B (G1)		(G2)		REMARKS
	R	T	R	T	R	T	R	T	
Q3703	4		0		4				M CHECK → OFF

MONITOR UNIT PARTS LAYOUT

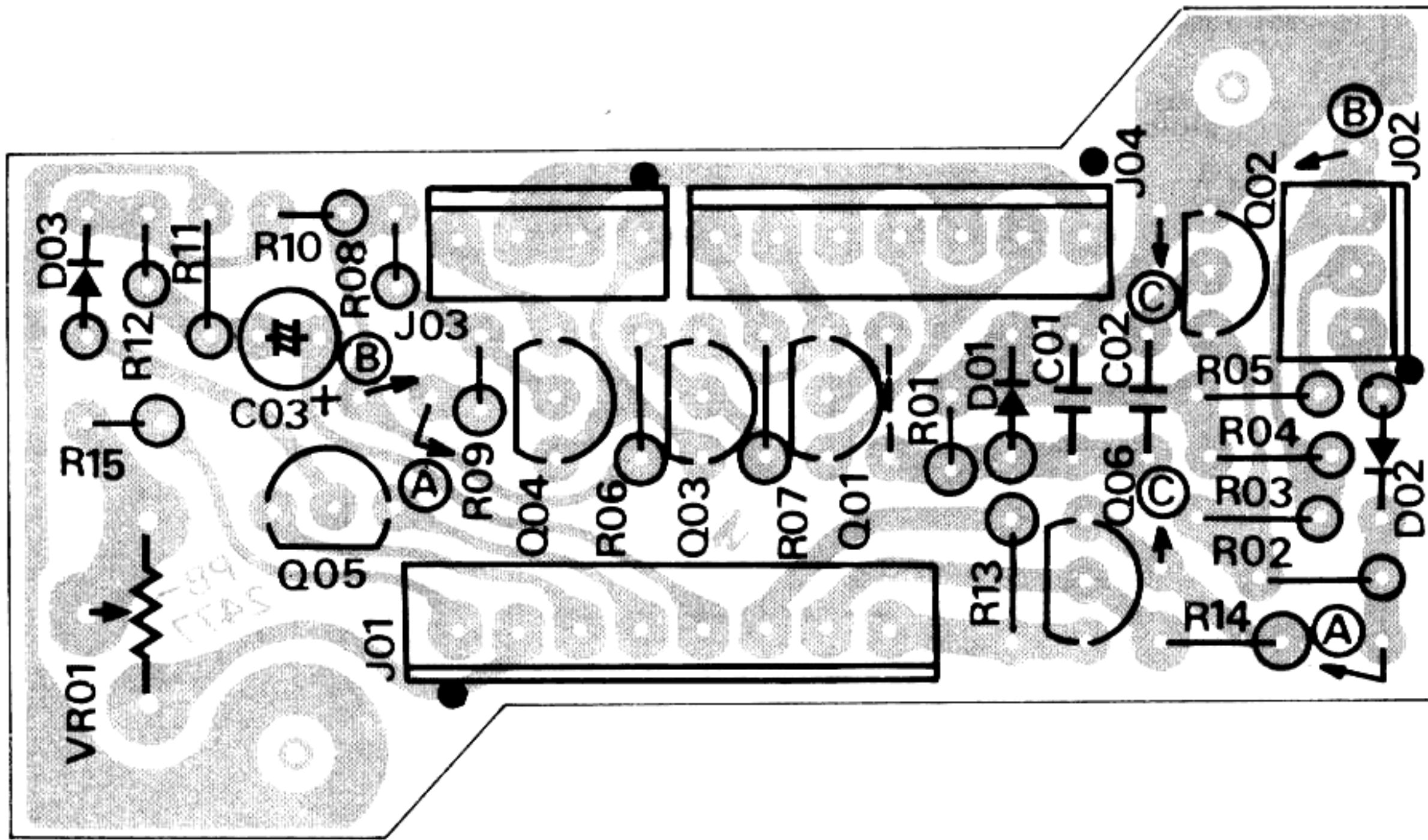

Viewed from component side

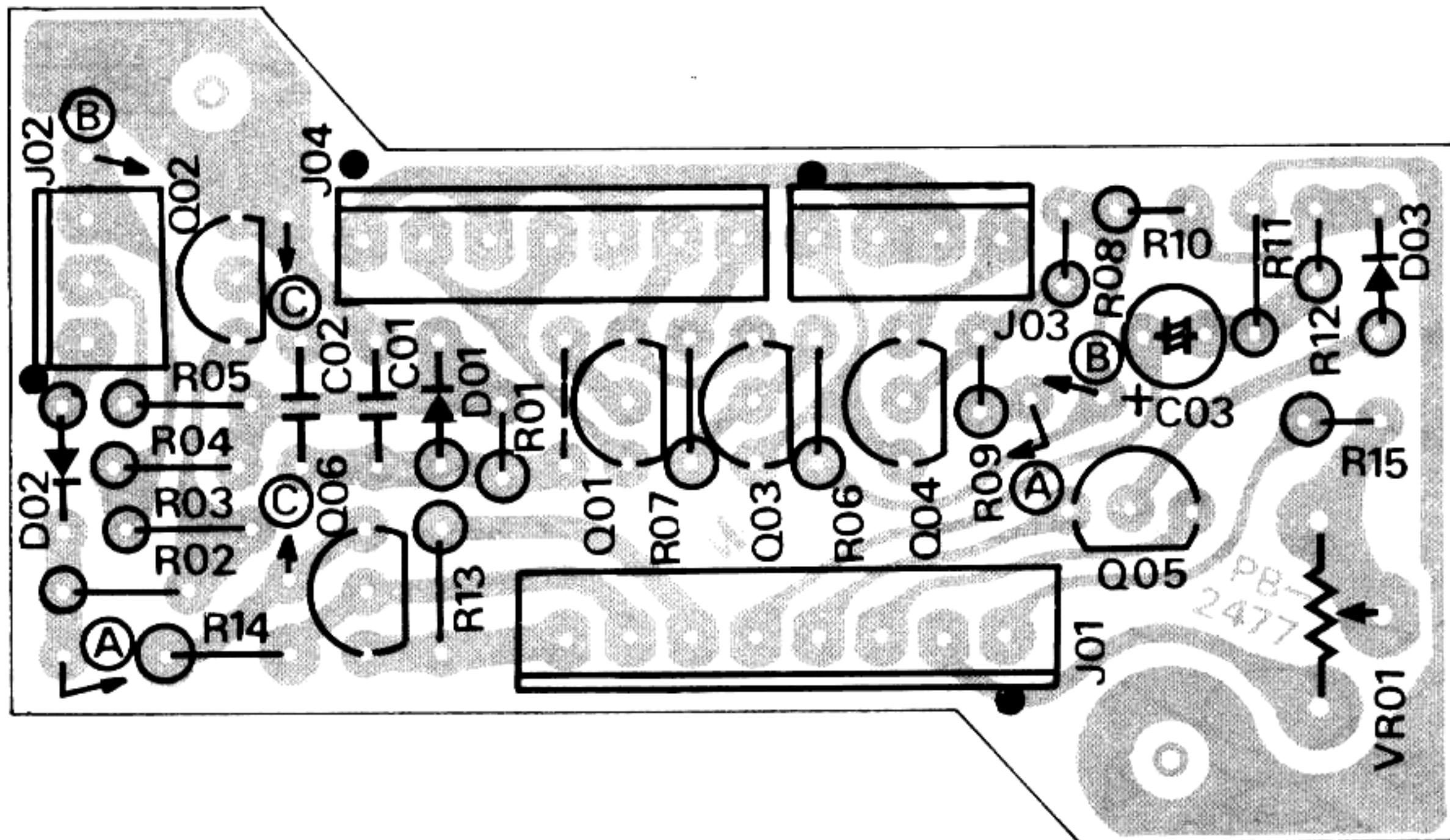

Viewed from solder side

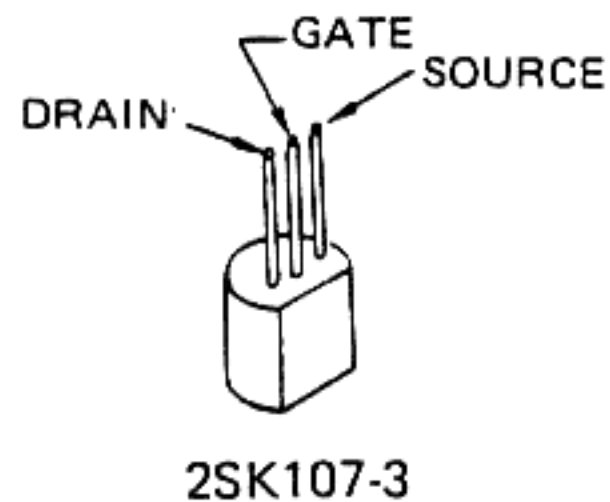
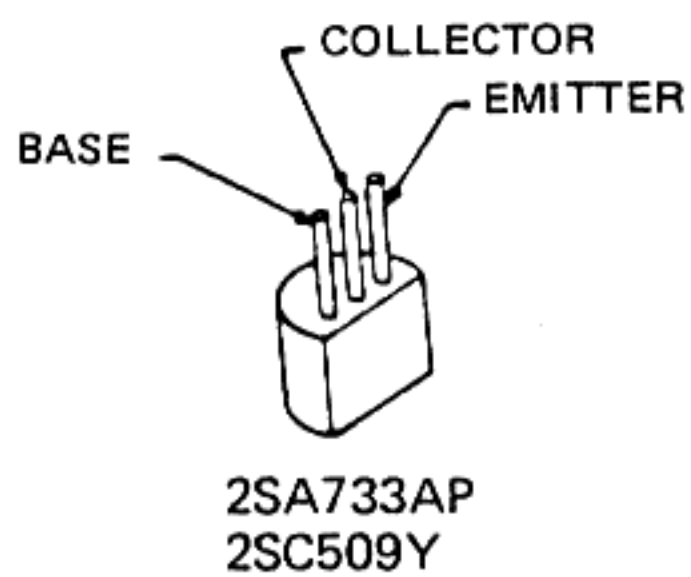

MONITOR UNIT

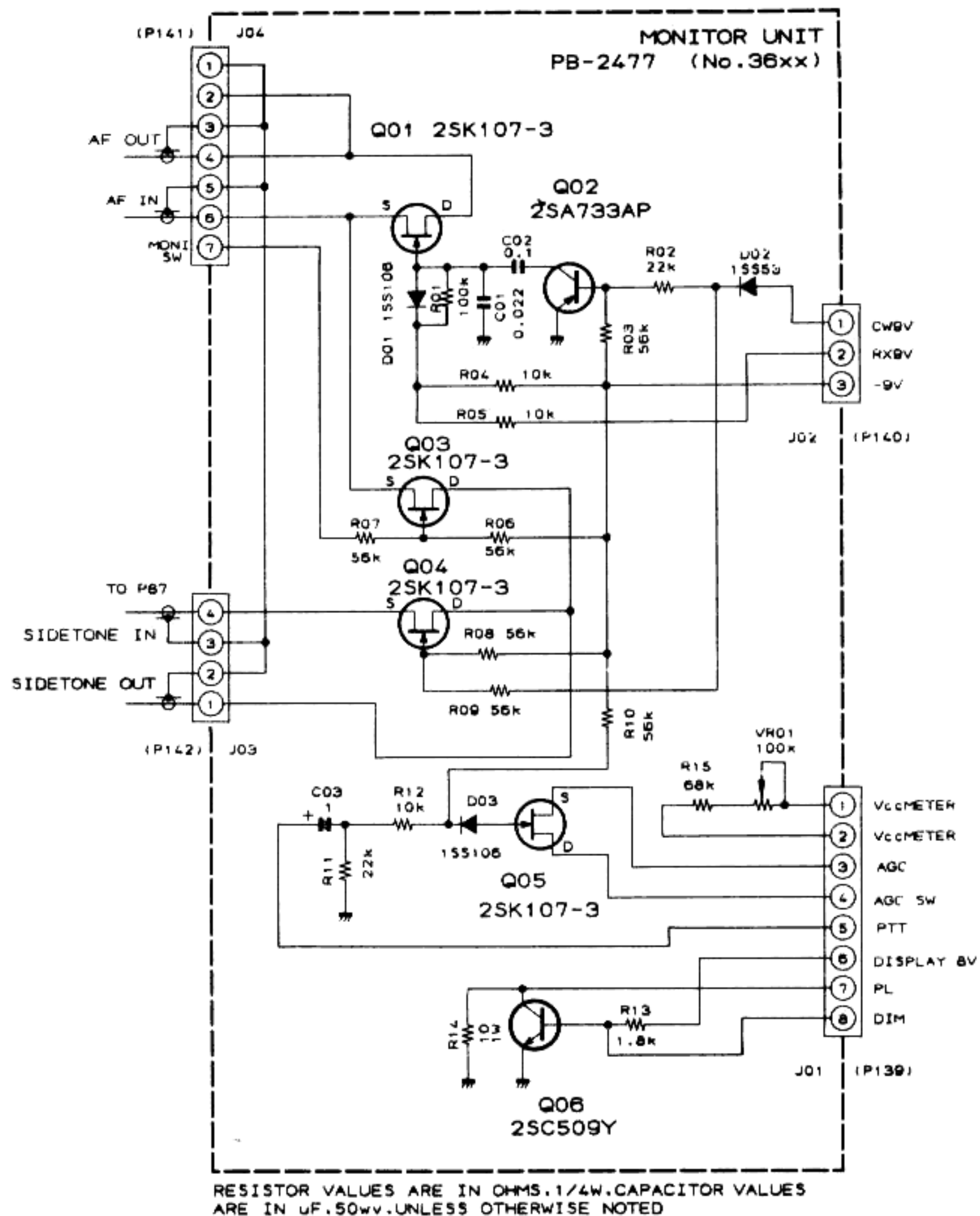

MONITOR UNIT VOLTAGE CHART

(DC VOLTS)

	E (S)		C (D)		B (G1)		(G2)		REMARKS
	R	T	R	T	R	T	R	T	
Q3601	0		0		0				CW
Q3602	0		0		3				RX
Q3603	0		0		-9				AGC → OFF SLOW RF GAIN → MAX
Q3604	0		0		0				
Q3605	3		2.5		-9				
Q3606	0		0		0.6				DIM SW → OFF
	0		2.5		0				DIM SW → ON

100W PA UNIT PARTS LAYOUT

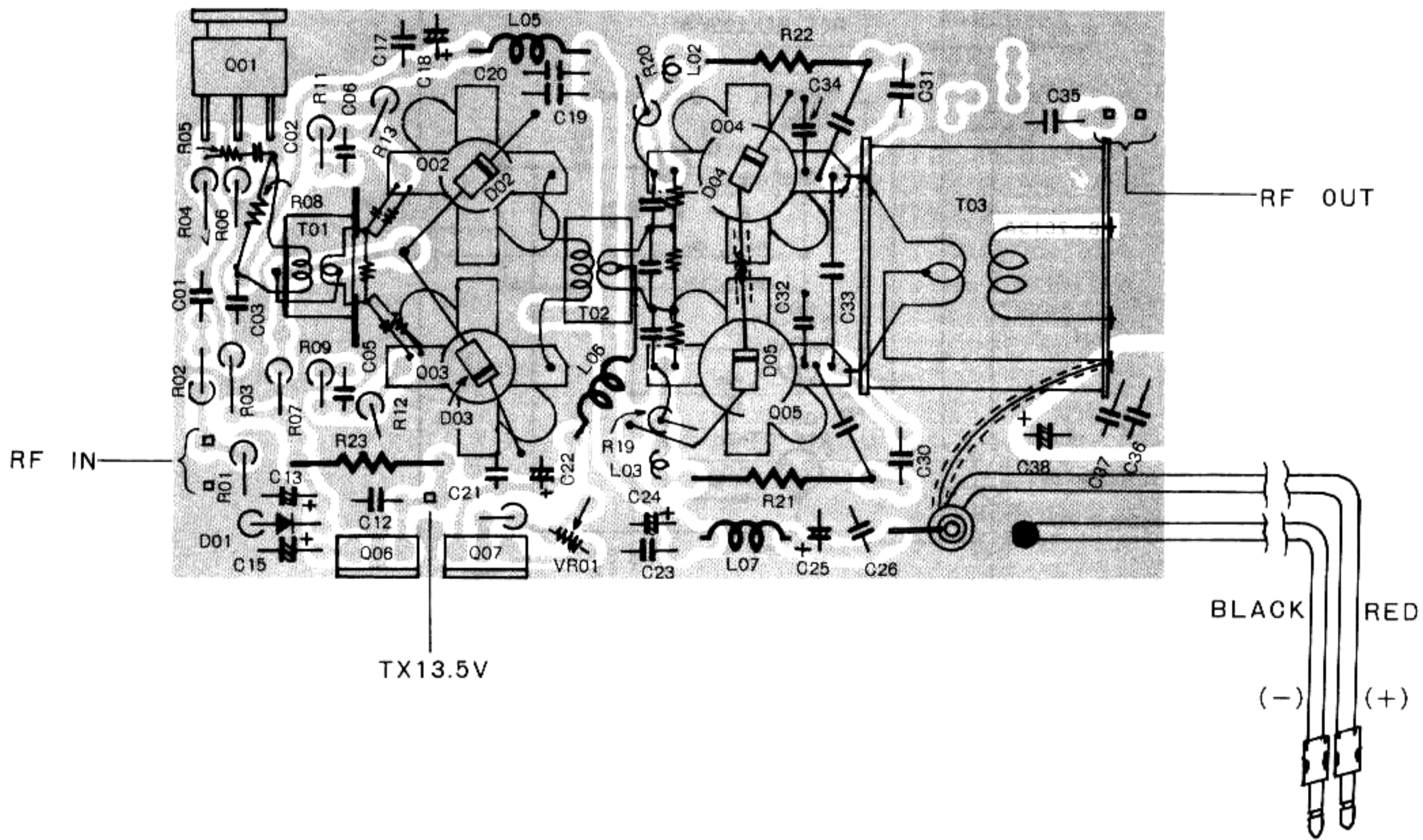

100W PA UNIT VOLTAGE CHART

(DC VOLTS)

	E (S)		C (D)		B (G1)		(G2)		REMARKS
	R	T	R	T	R	T	R	T	
Q8001		0.4		13.5		1.2			
Q8002		0		13.5		0.7			
Q8003		0		13.5		0.7			
Q8004		0		24		0.7			
Q8005		0		24		0.7			
Q8006		IN 13.5		COM 0		OUT 8			
Q8007		0.7		8		1.4			



100W PA UNIT

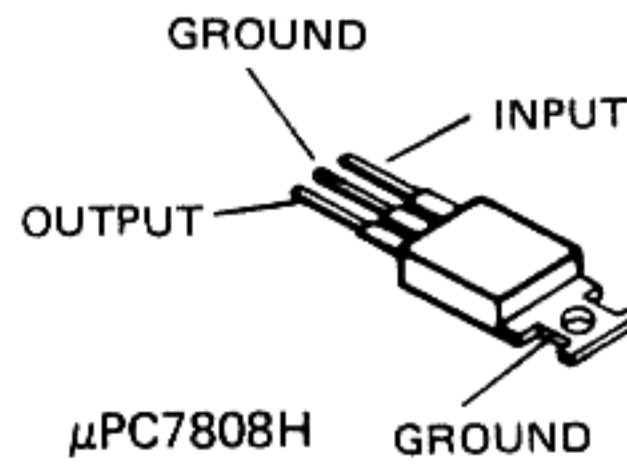
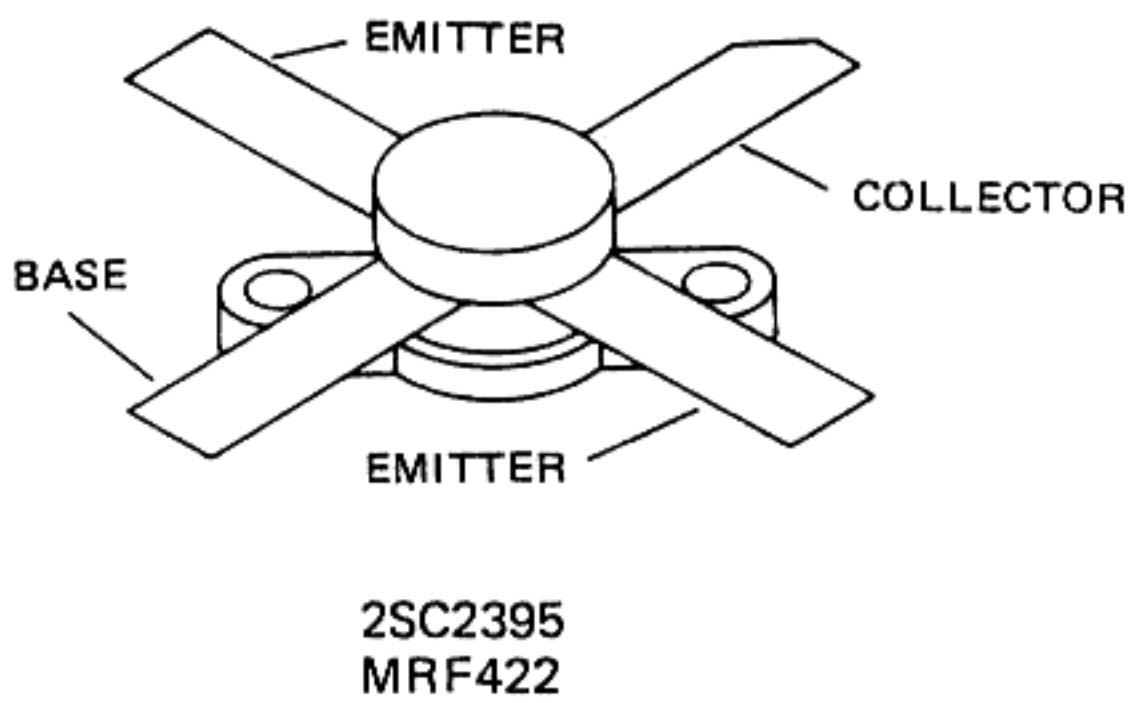
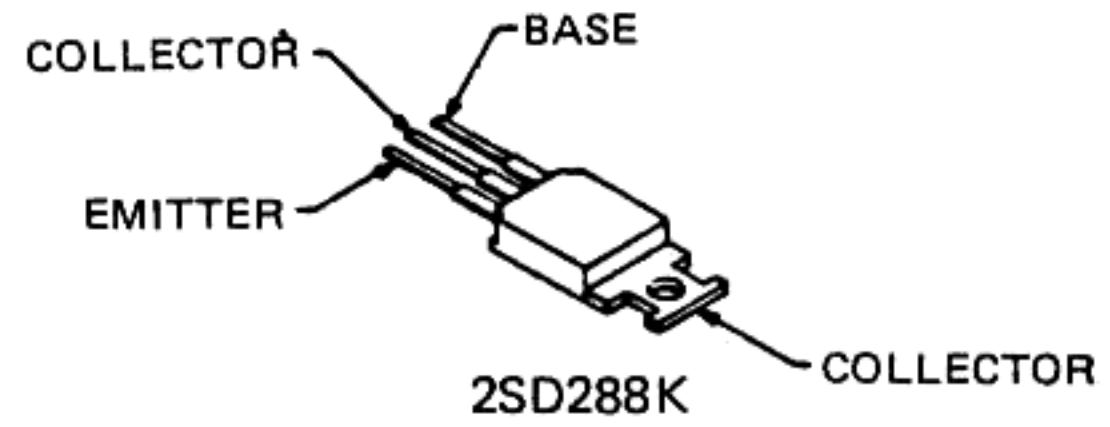
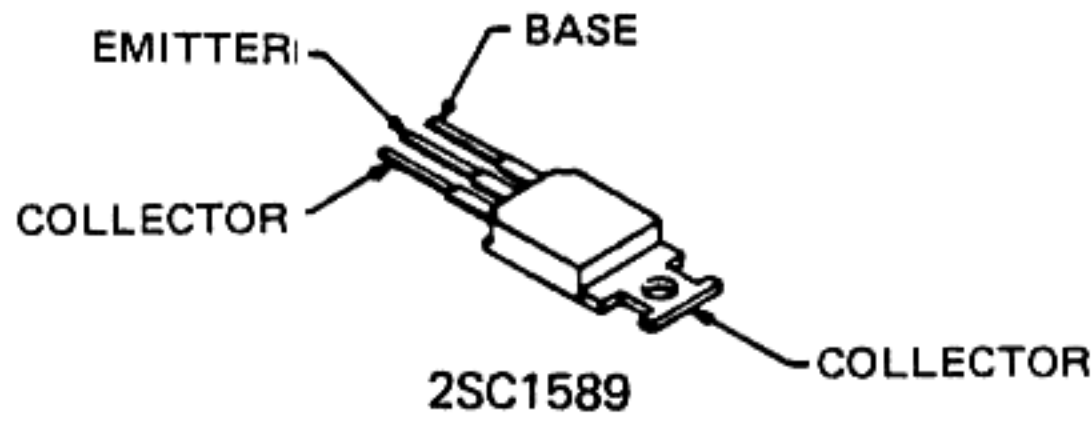
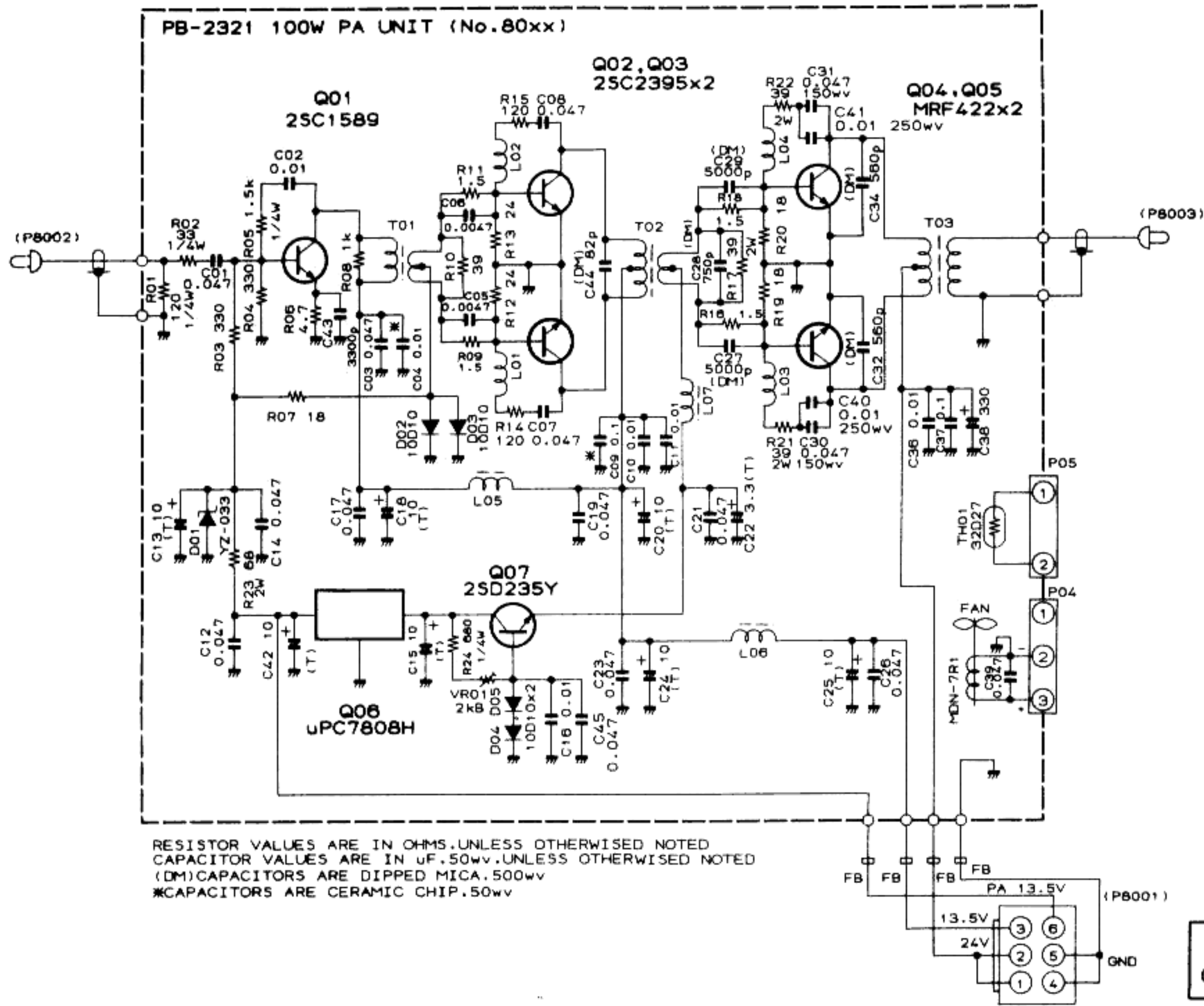
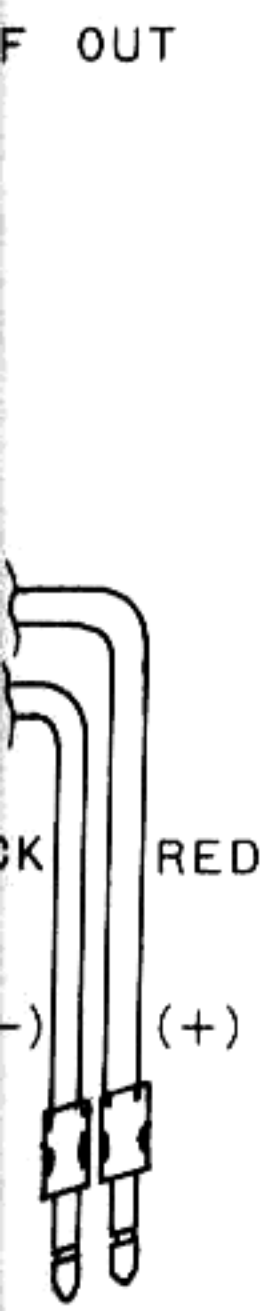

10W PA UNIT

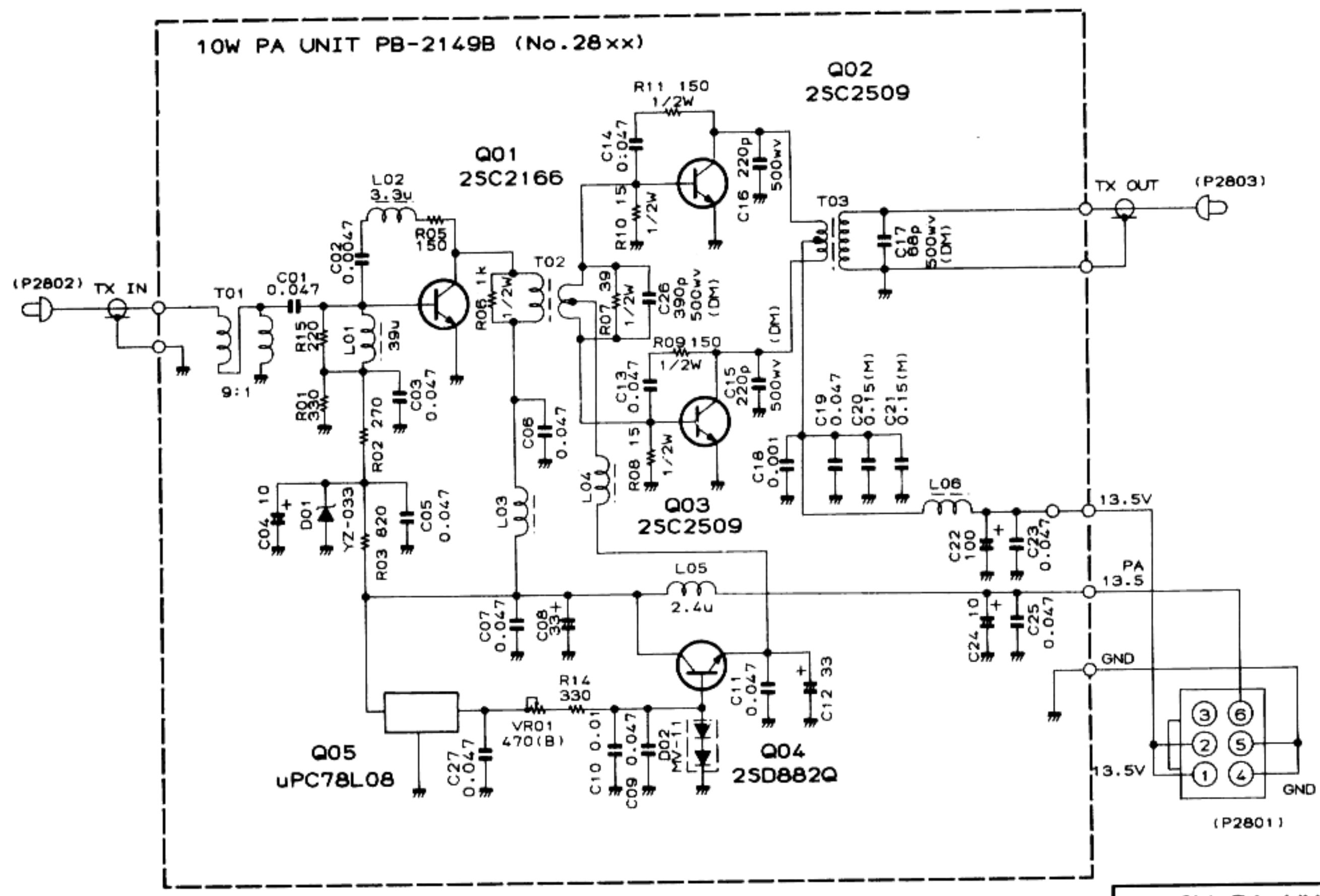

RESISTOR VALUES ARE IN OHMS, 1/4W, AND CAPACITOR VALUES ARE IN μ F, 50V.
 INDUCTOR VALUES ARE IN HENRIES, UNLESS OTHERWISE NOTED
 ELECTROLYTIC CAPACITOR VALUES ARE IN μ F, 16V UNLESS OTHERWISE NOTED
 (M) CAPACITORS ARE POLYESTER FILM, 50V
 (DM) CAPACITORS ARE DIPPED MICA, 50V

**10W PA UNIT
CIRCUIT DIAGRAM**

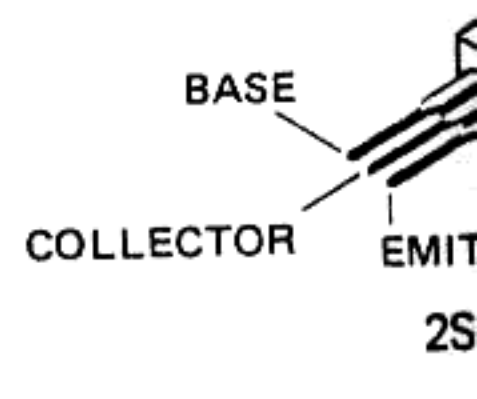
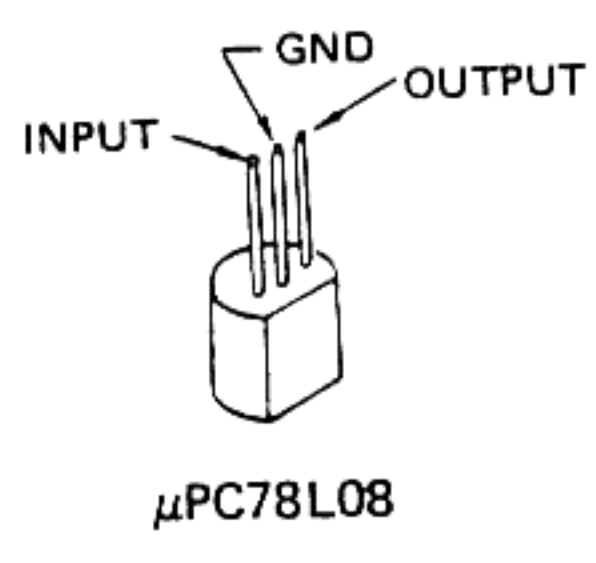

10W PA UNIT PARTS LAYOUT

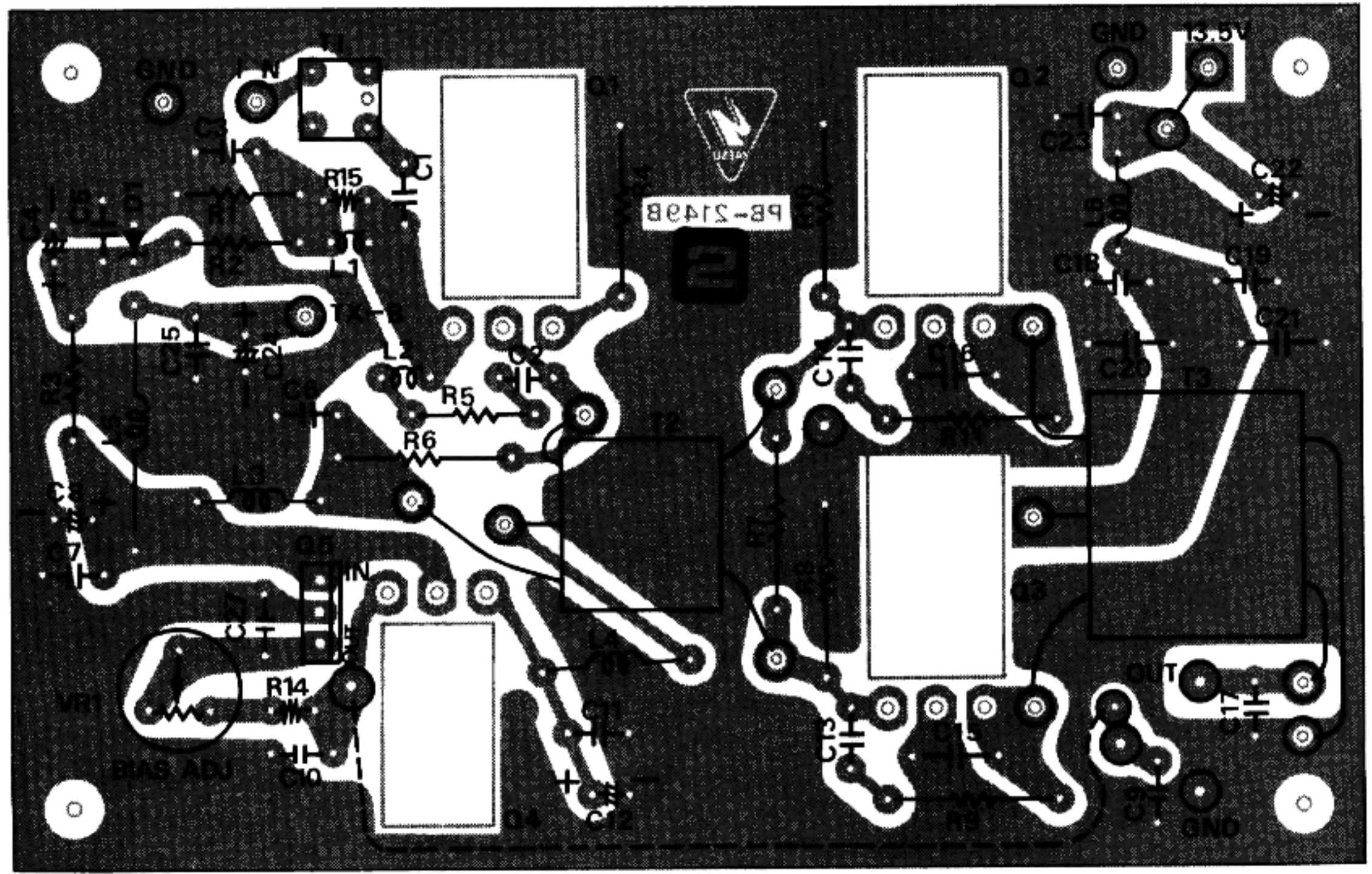

3031

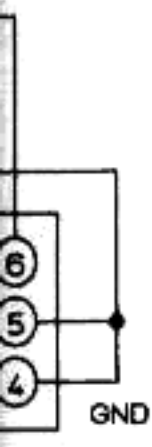

28011

PA UNIT
PART DIAGRAM

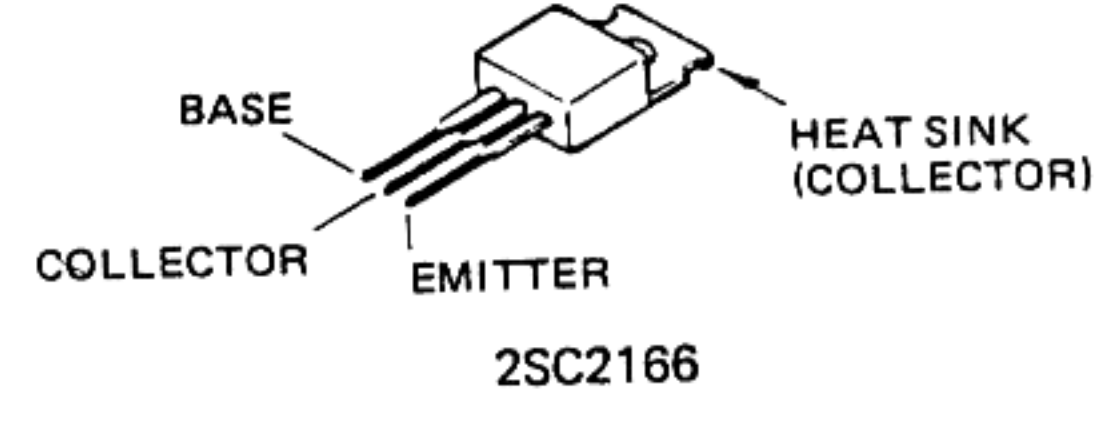
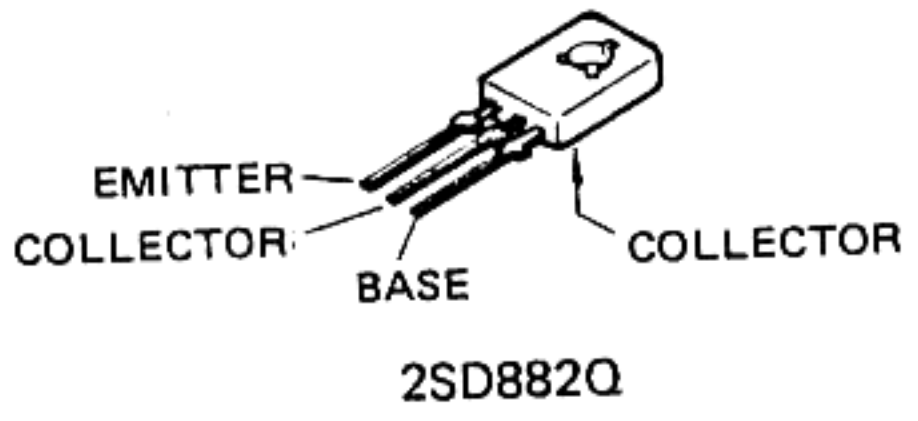
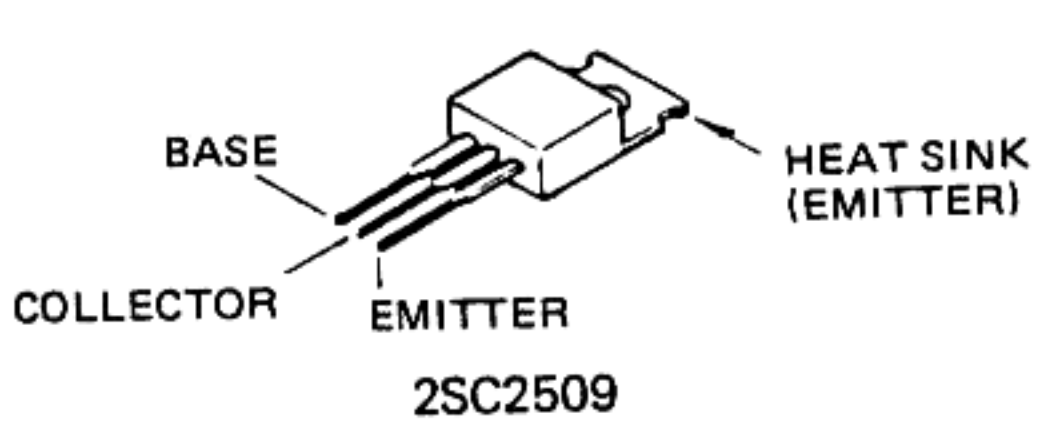

TUOYA 100W PS UNIT

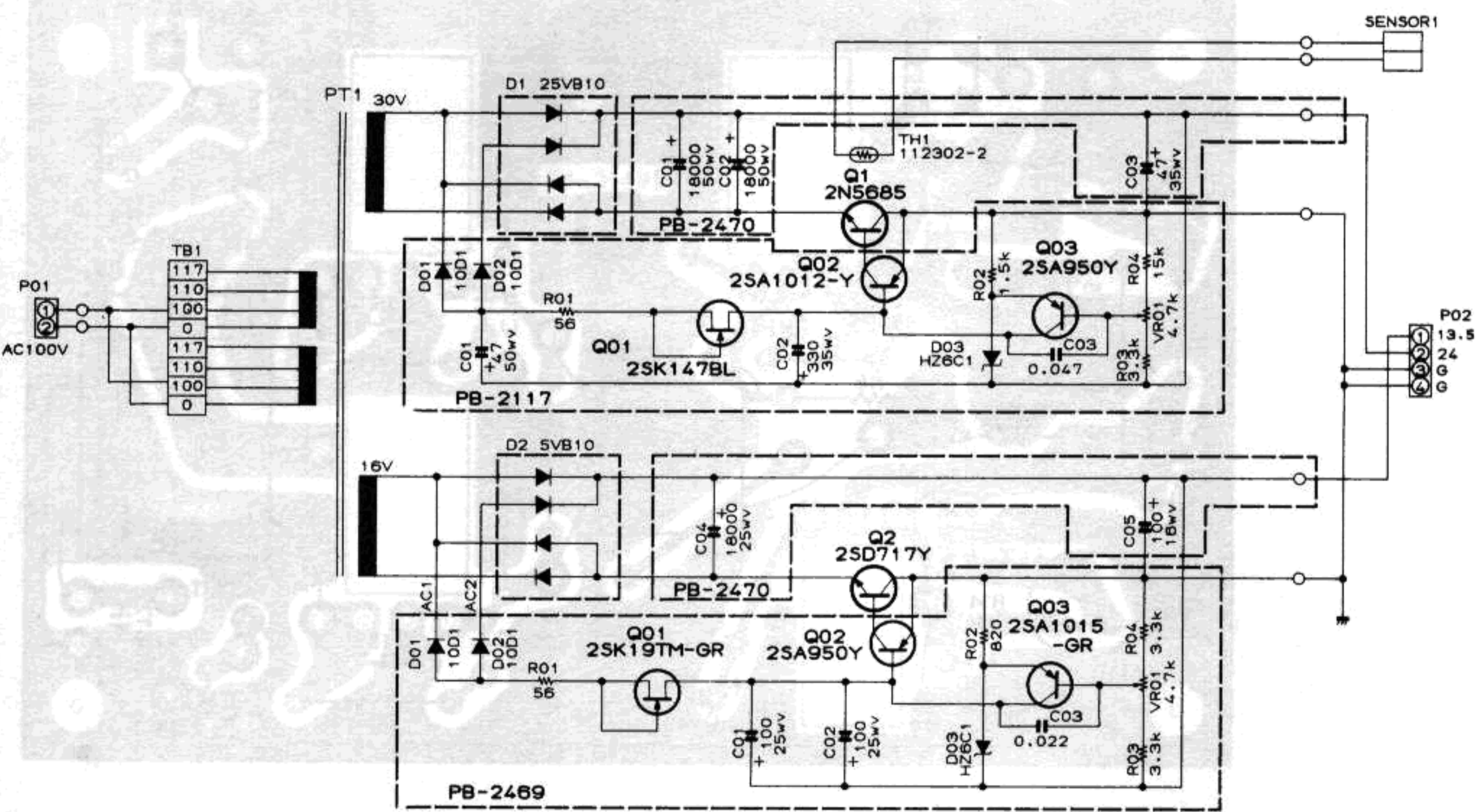

RESISTOR VALUES ARE IN OHMS, 1/4W, AND CAPACITOR VALUES ARE IN μ F, 50V, AND INDUCTOR VALUES ARE IN HENRIES UNLESS OTHERWISE NOTED

100W PS UNIT

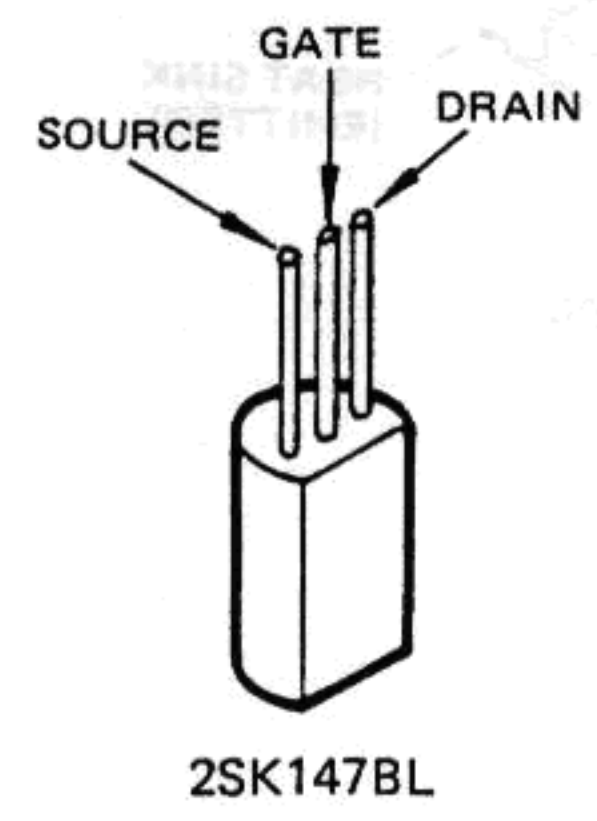
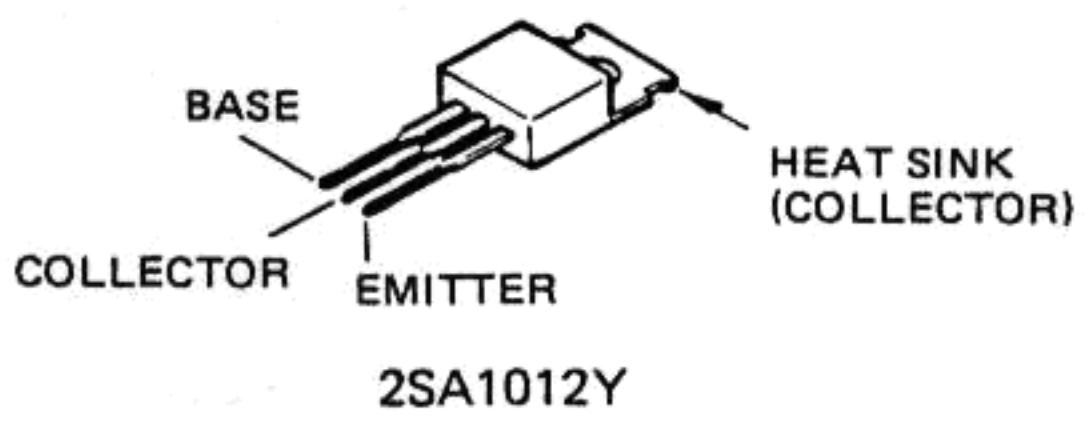
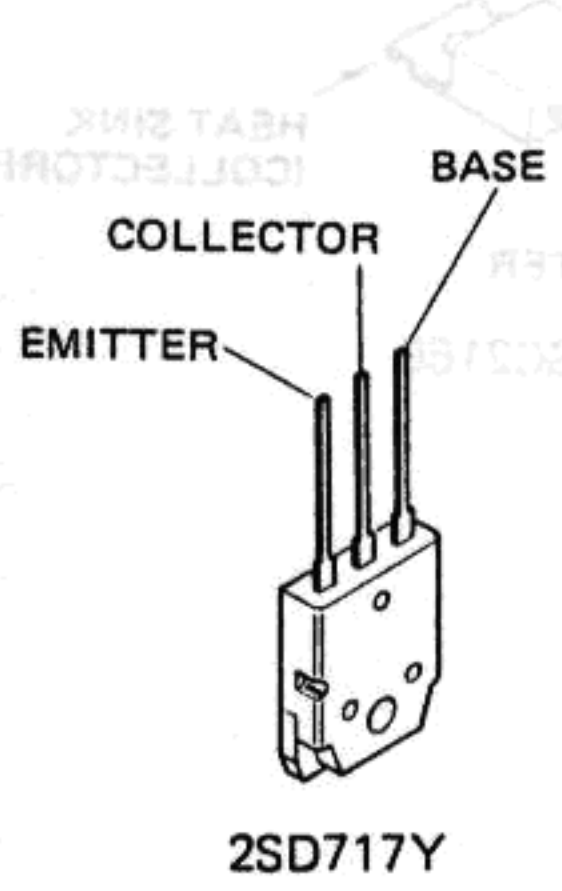
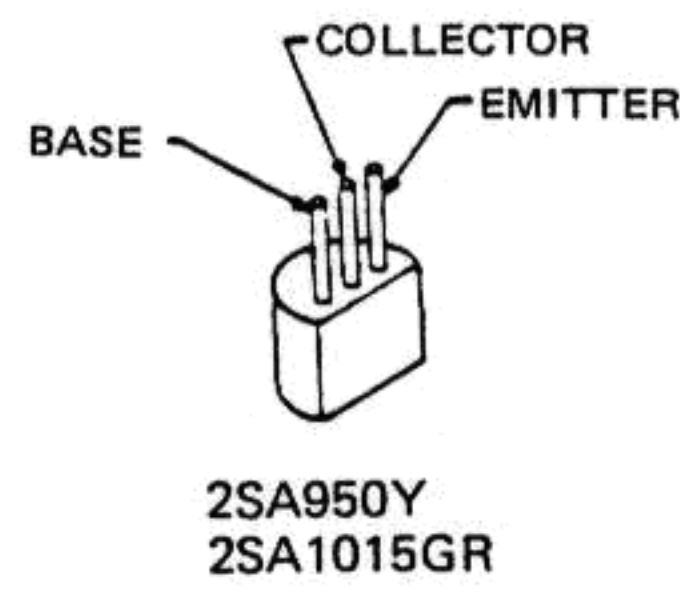
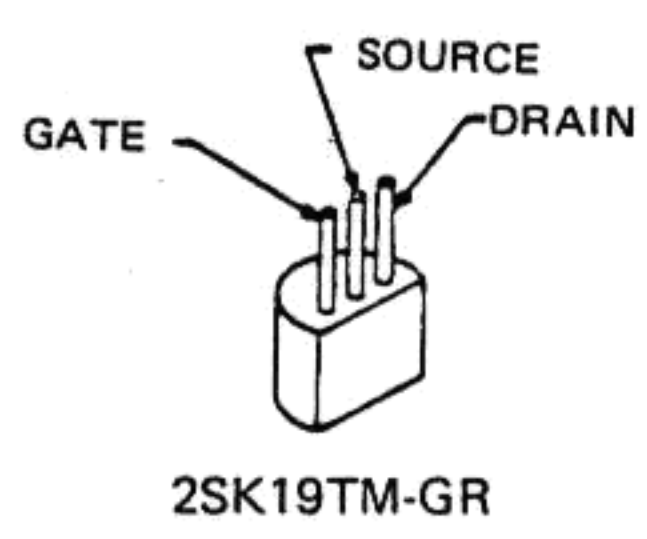
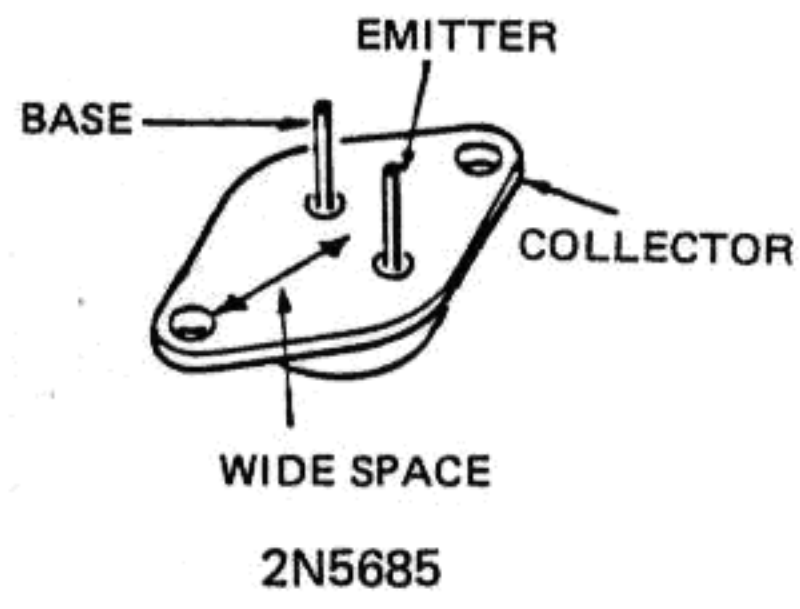

100W PS UNIT PARTS LAYOUT

PB-2470

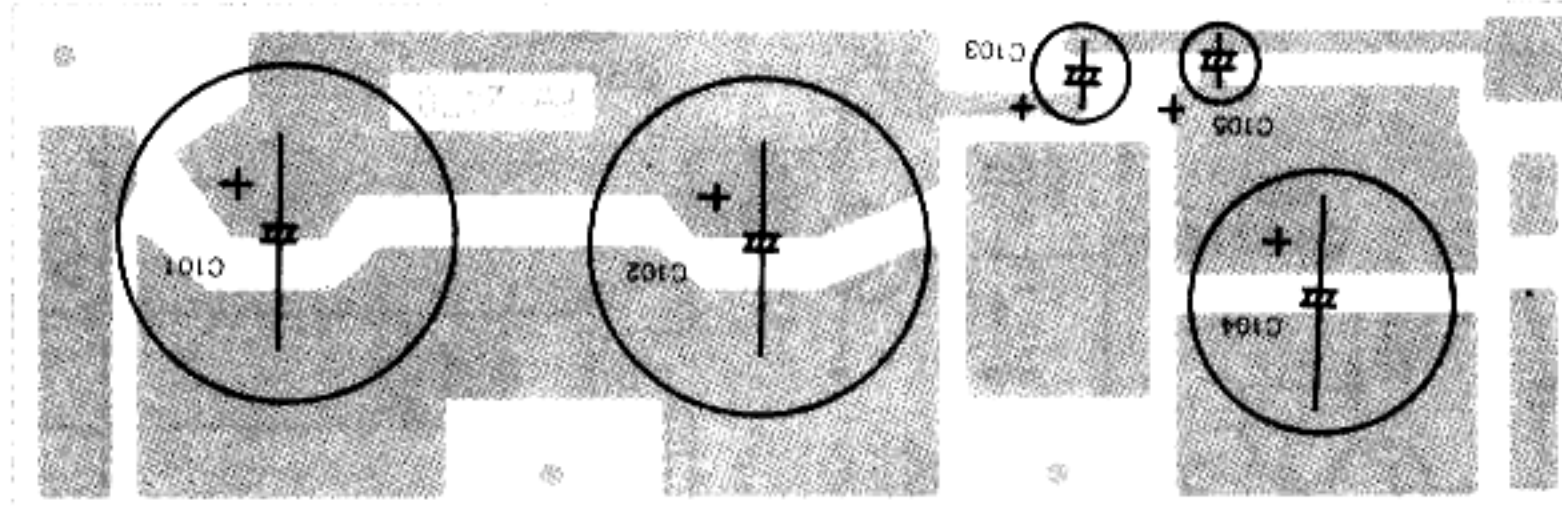

Viewed from solder side

24V AVR UNIT (PB-2117)

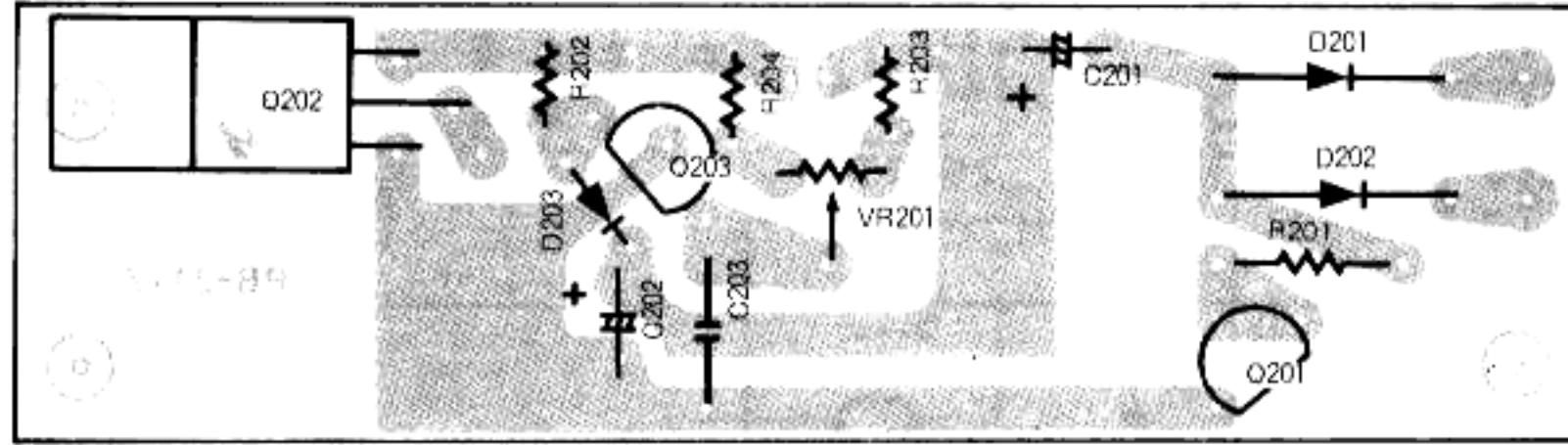

Viewed from component side

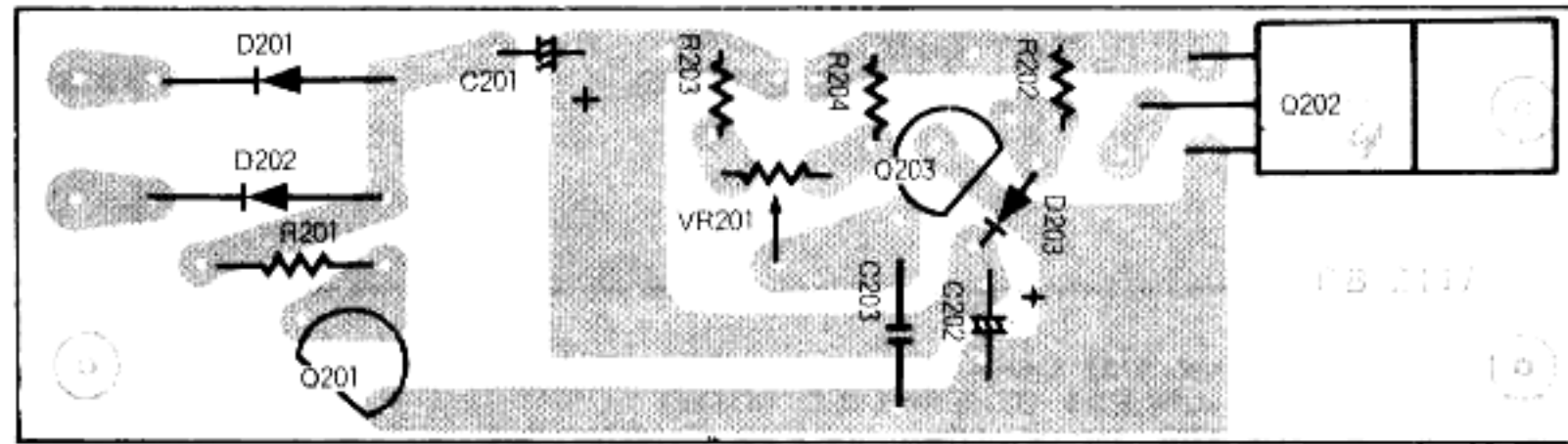

Viewed from solder side

13.5V AVR UNIT (PB-2469)

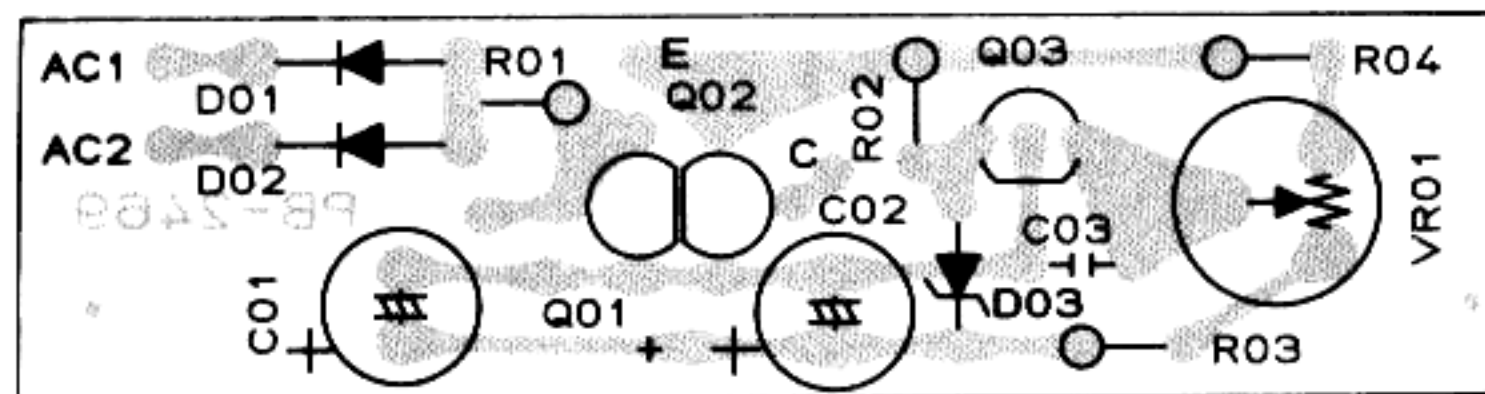

Viewed from component side

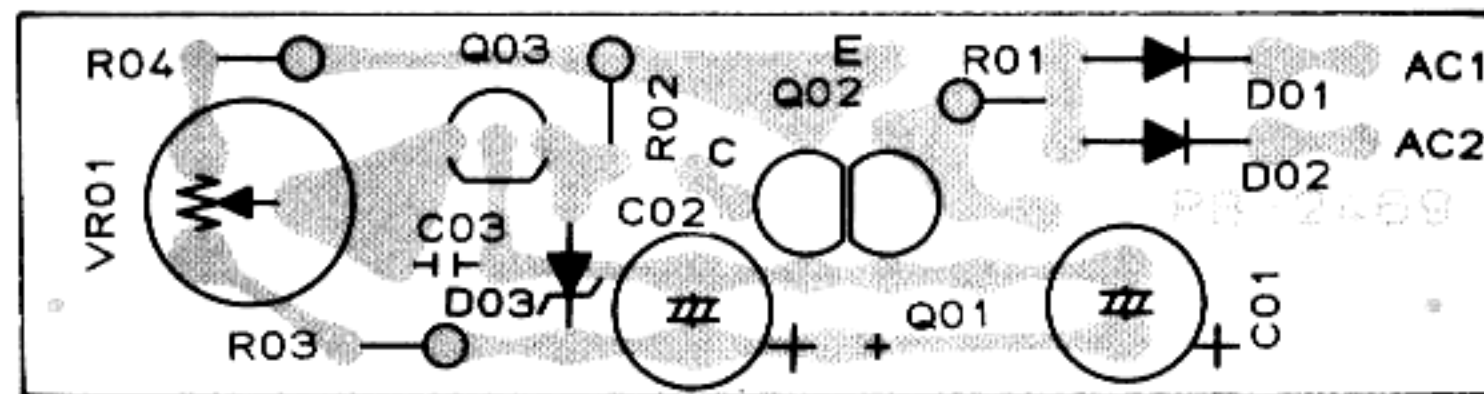

Viewed from solder side

10W PS UNIT

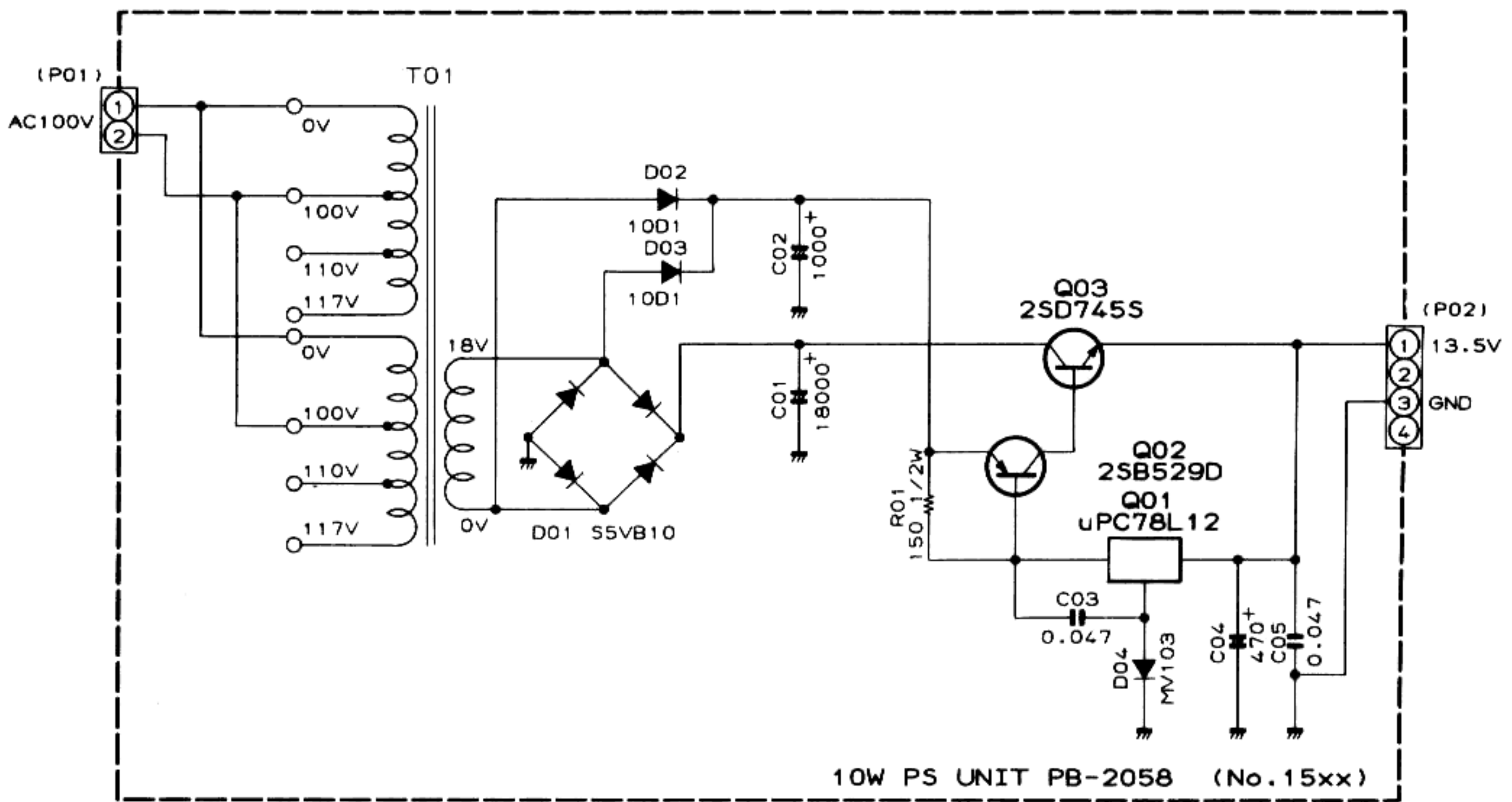

RESISTOR VALUES ARE IN OHMS. AND CAPACITOR VALUES ARE IN μF. 50V. UNLESS OTHERWISE NOTED

10W PS UNIT

10W PS UNIT PARTS LAYOUT

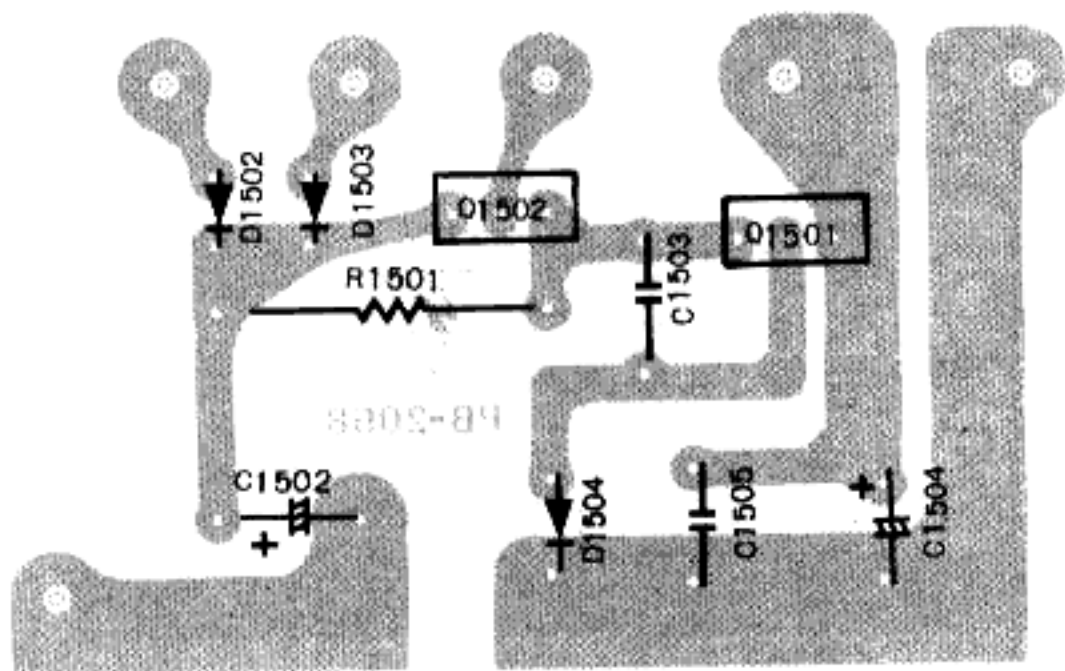

Viewed from component side

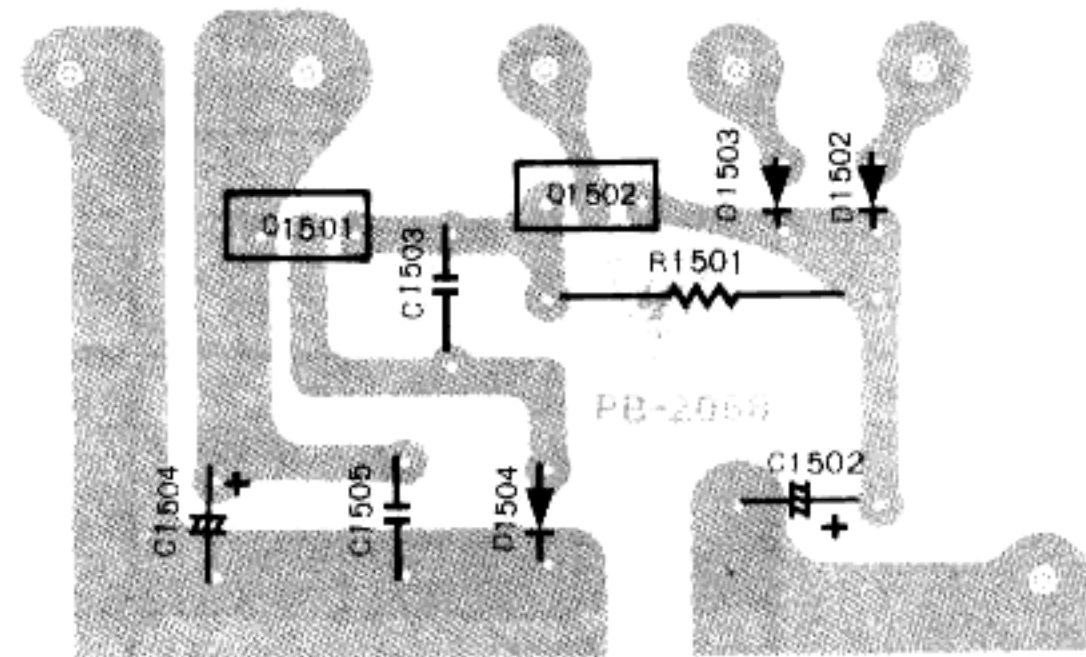

Viewed from solder side

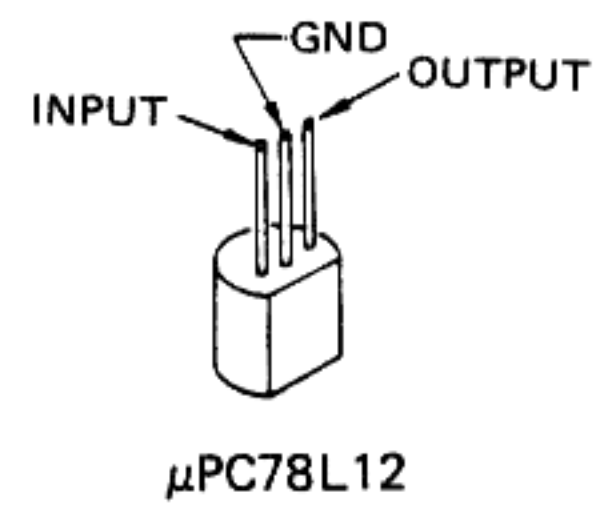
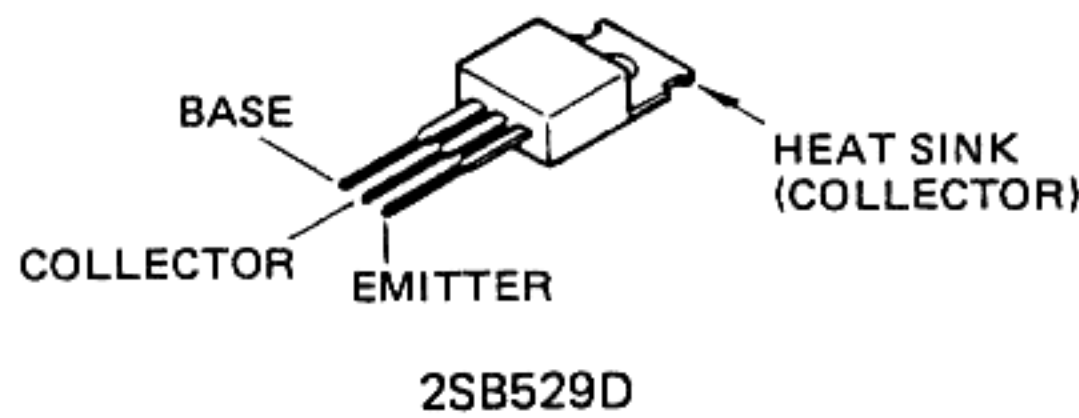
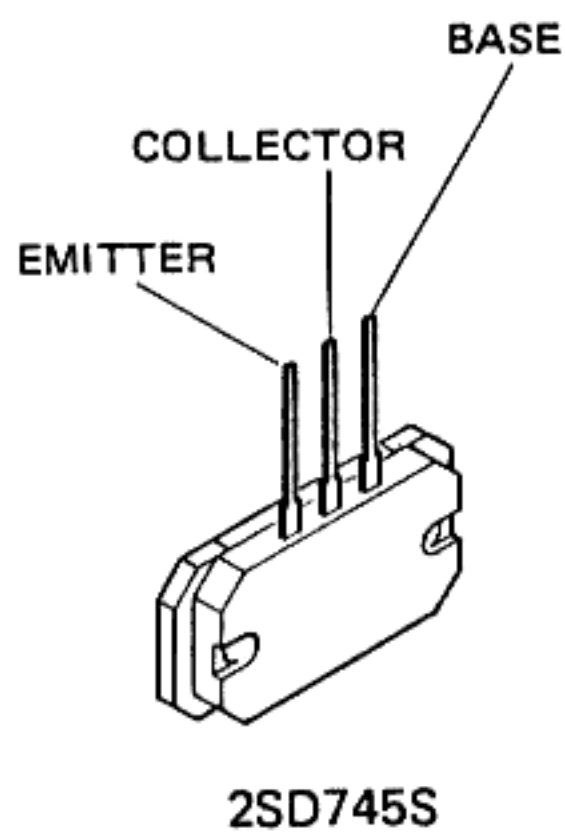

PI UNIT PARTS LAYOUT

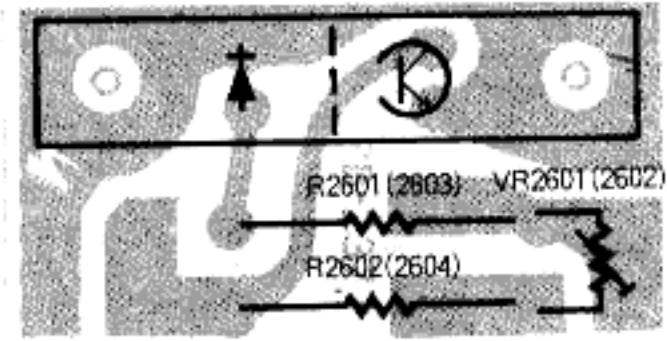
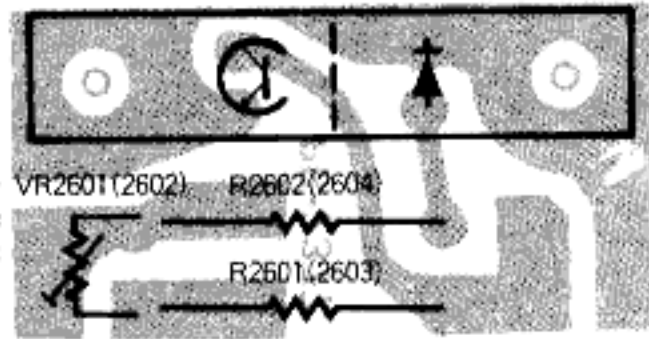

Viewed from solder side

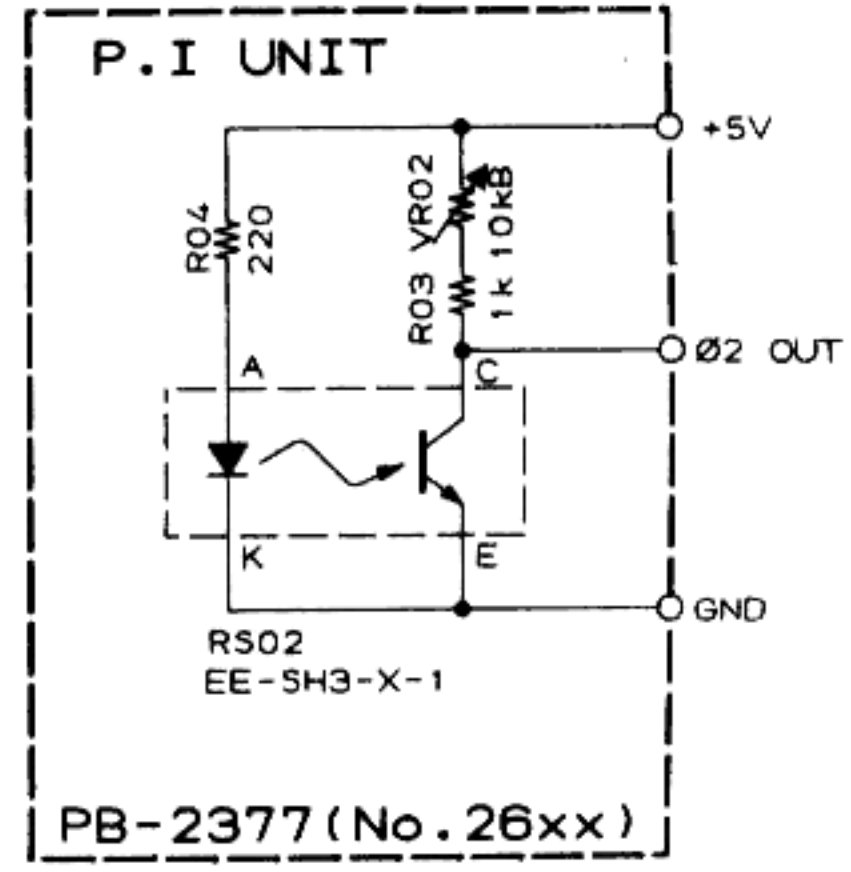
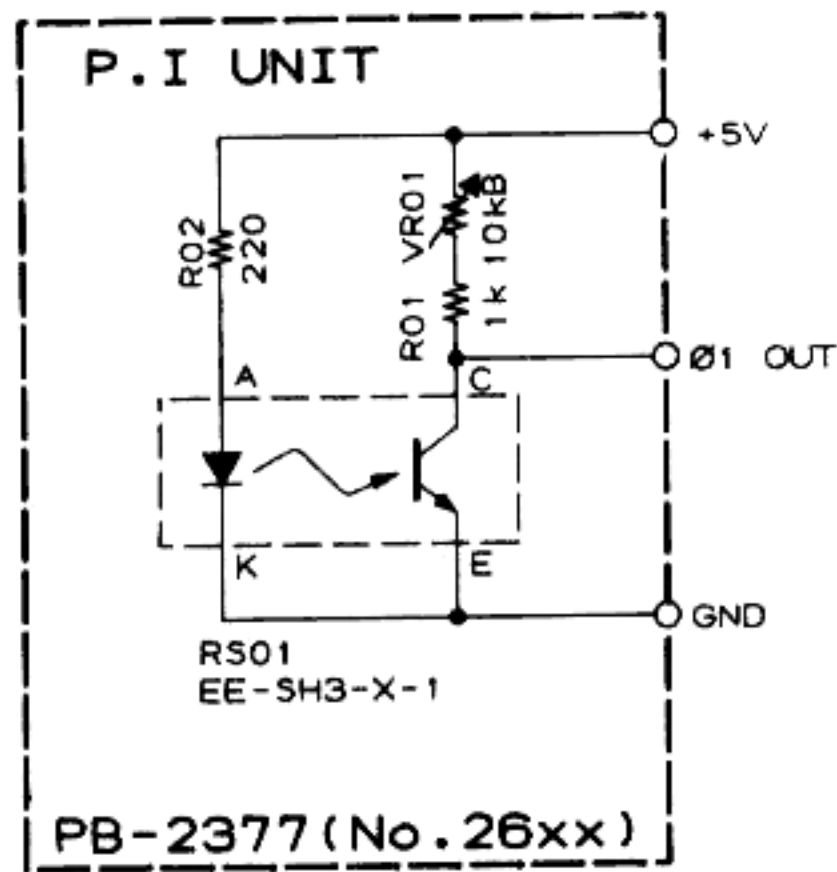
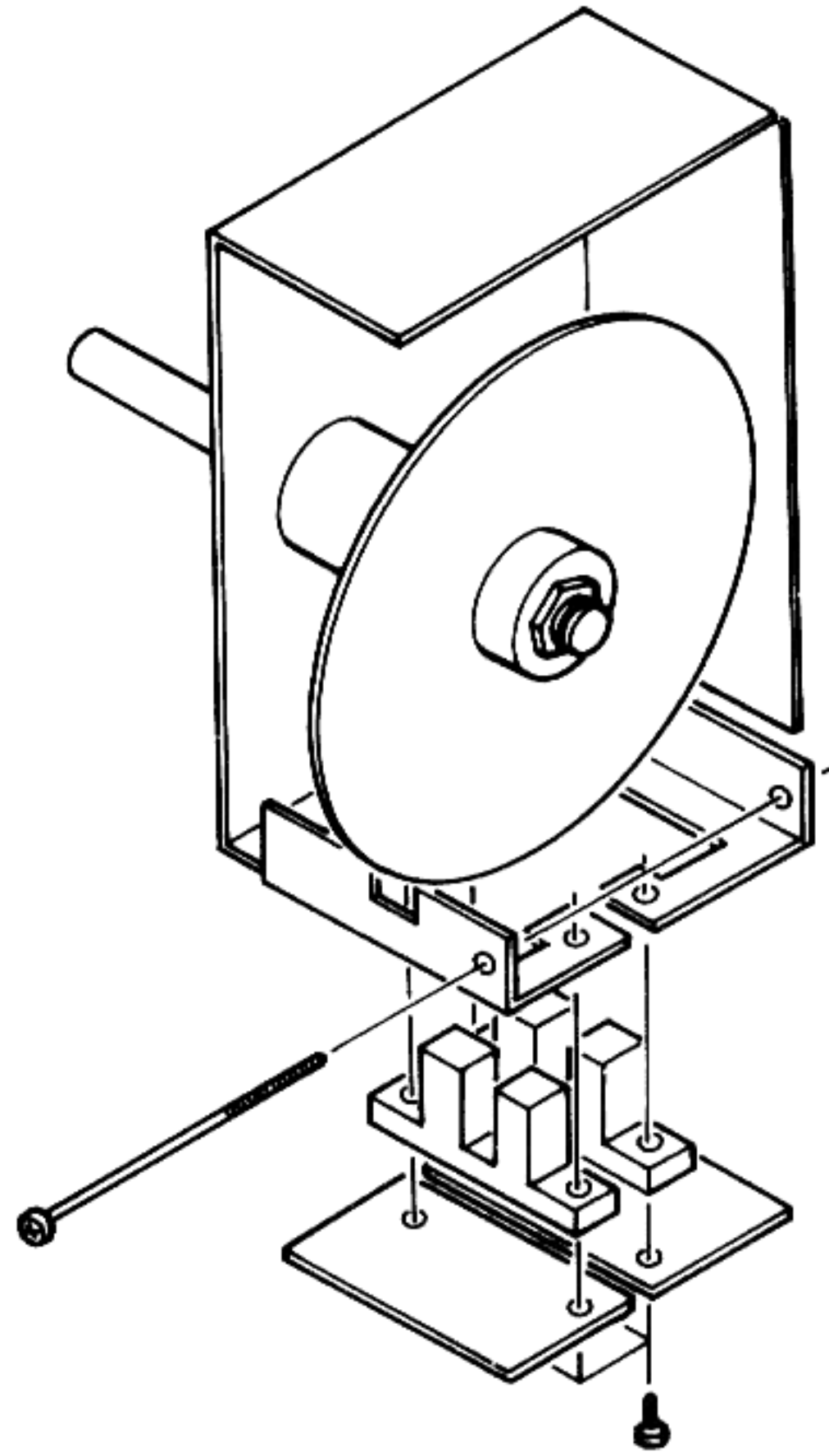

IF SHIFT UNIT

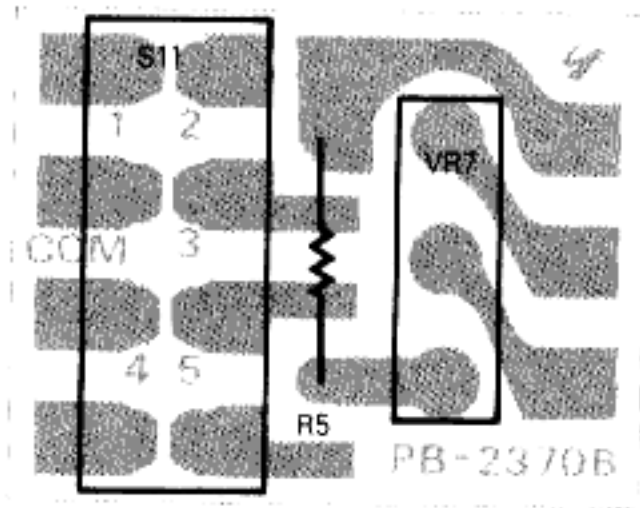

Viewed from solder side

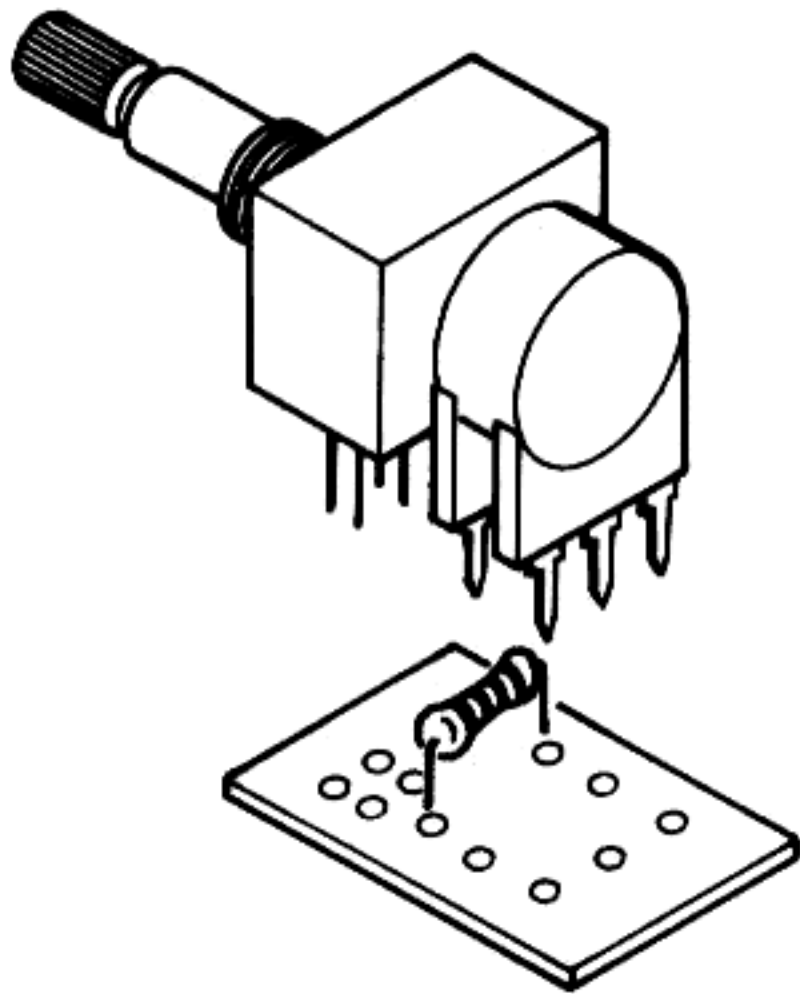

PB-2300

BCD ENCODER (O=ON)

SW. POSITION \ PIN	1	2	3	4	5	6
1						
2	0					
3		0				
4	0	0				
5			0			
6	0		0			
7		0	0			
8	0	0	0			
9				0		
10	0			0		
11		0		0		
12	0	0		0		
13			0	0		
14	0		0	0		
15		0	0	0		
16	0	0	0	0		
17					0	
18	0				0	
19		0			0	
20	0	0			0	
21			0		0	
22	0		0		0	
23		0	0		0	
24	0	0	0		0	
25				0	0	
26	0			0	0	
27		0		0	0	
28	0	0		0	0	
29			0	0	0	
30	0		0	0	0	
31		0	0	0	0	

U/D SWITCH UNIT PARTS LAYOUT

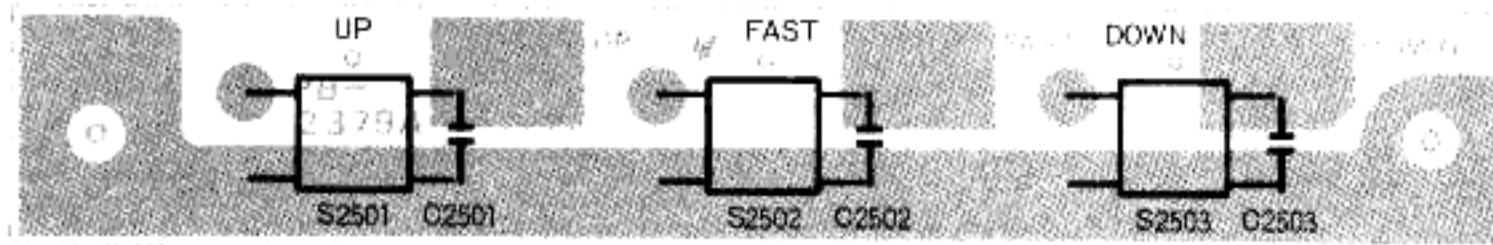

PB-2379A

CW PITCH UNIT PARTS LAYOUT

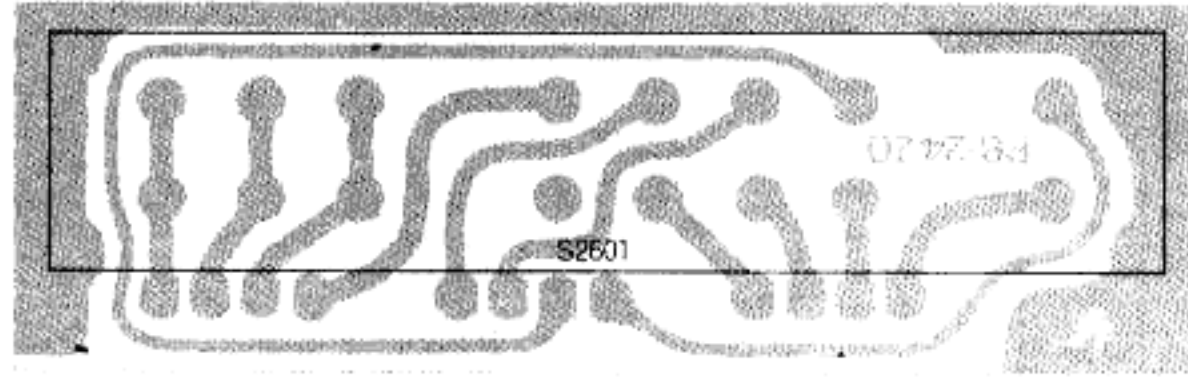

PB-2420

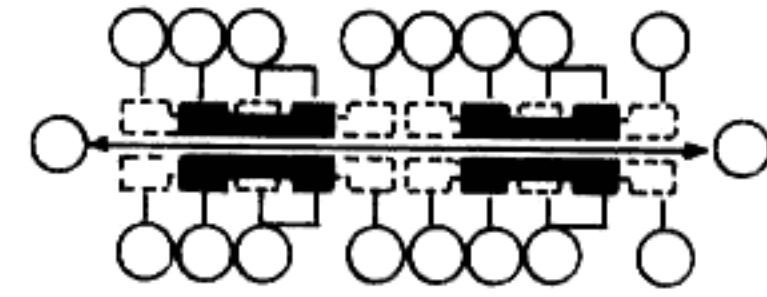

SWITCH UNIT (B) PARTS LAYOUT

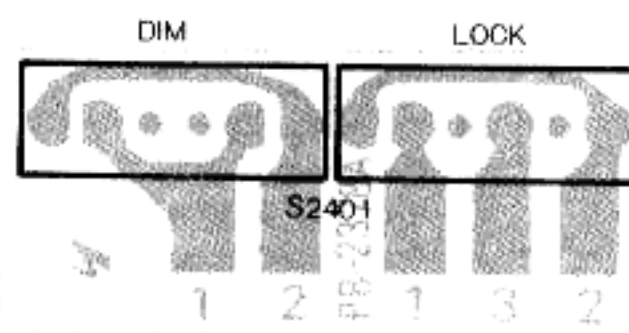

PB-2378A

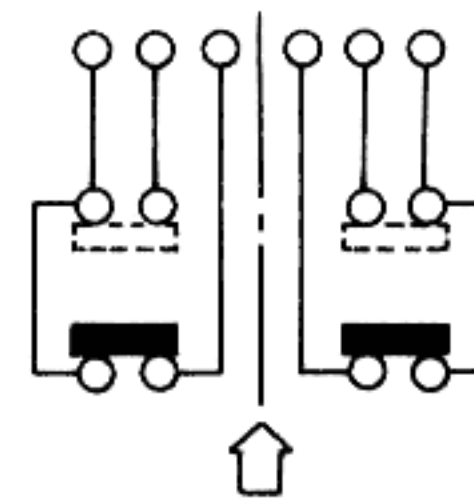

SWITCH UNIT (A) PARTS LAYOUT

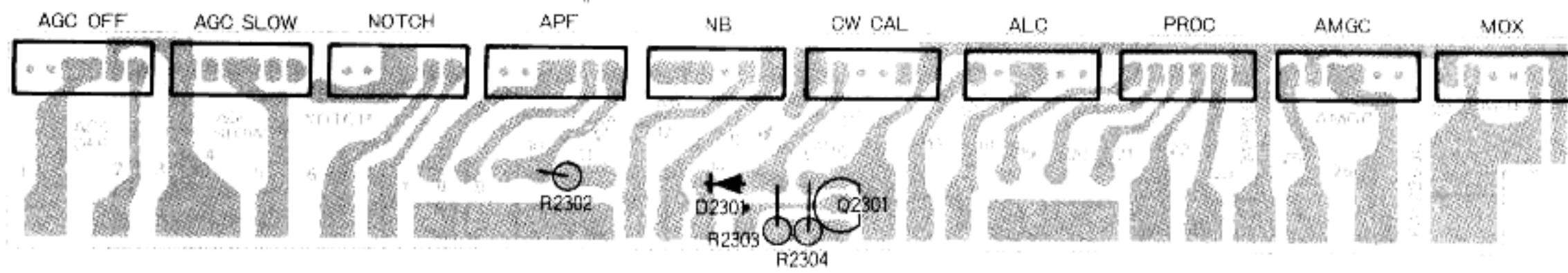

PB-2369C

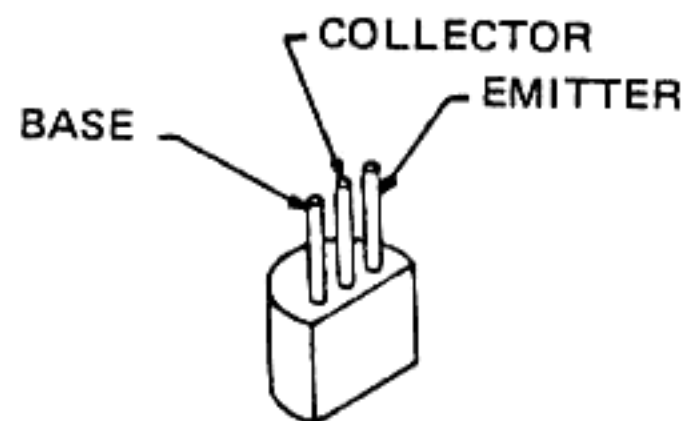

2SC1815GR

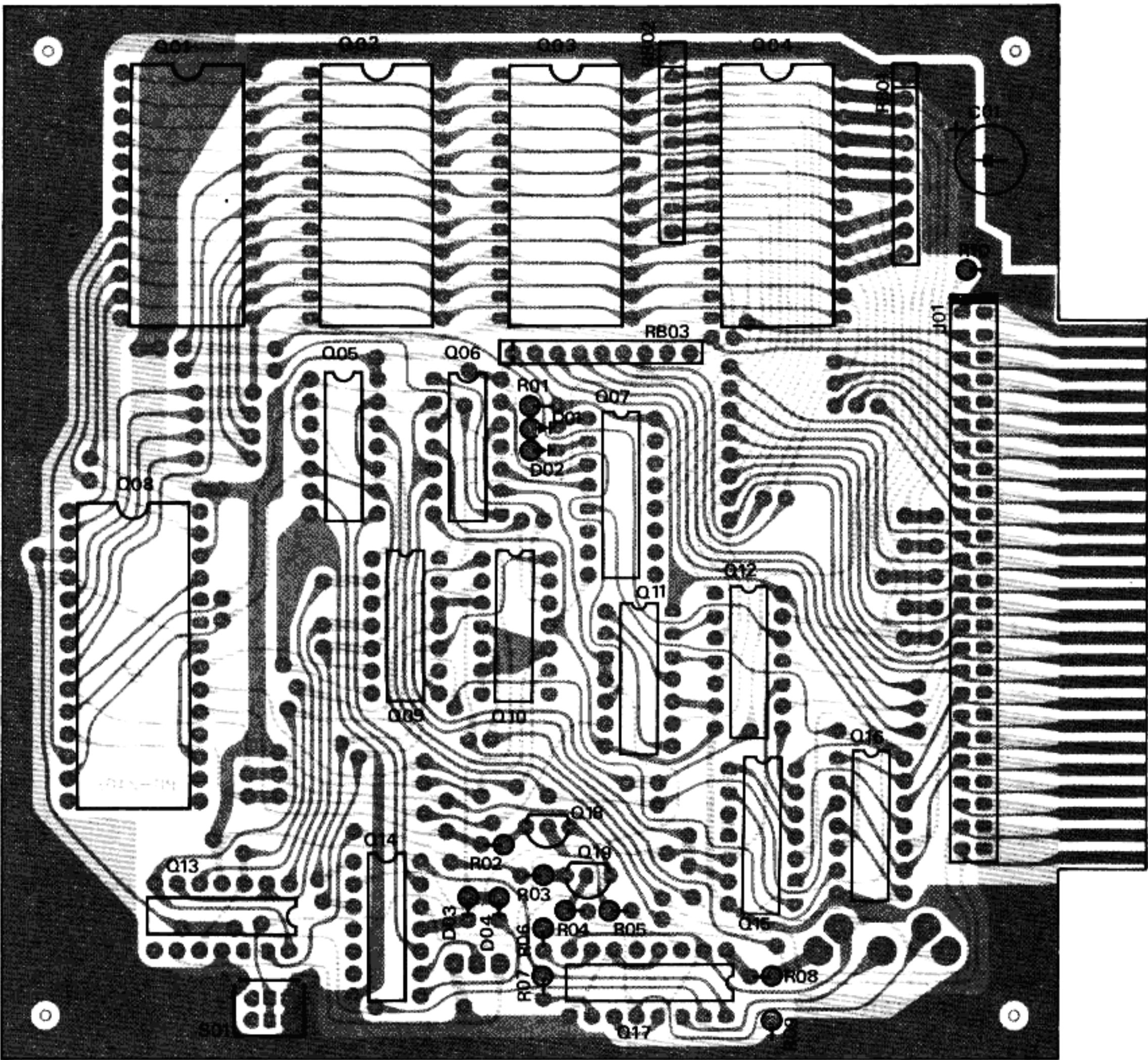

Viewed from component side

E UNIT PARTS LAYOUT

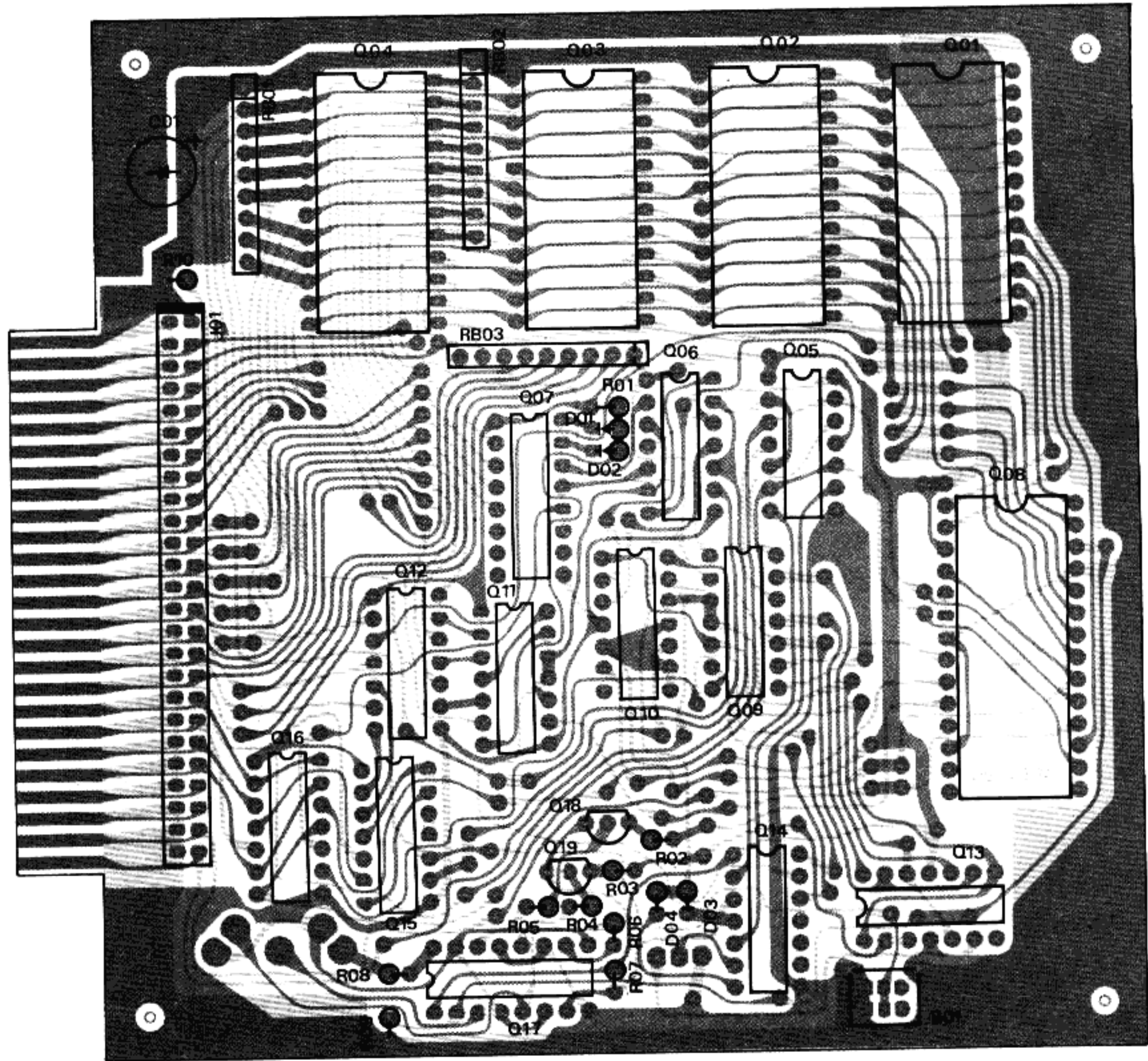

Viewed from solder side

FRONT PANEL EXPLODED VIEW

* KEY-TOP

R3080370A	V/U	R3080406C	CE
R3080371A	LDB	R3080390C	5
R3080400C	0	R3080391C	6
R3080401C	1	R3080392C	7
R3080402C	2	R3080393C	8
R3080403C	3	R3080394C	9
R3080404C	4	R3080395C	◀
R3080405C	ENT	R3080396C	▶

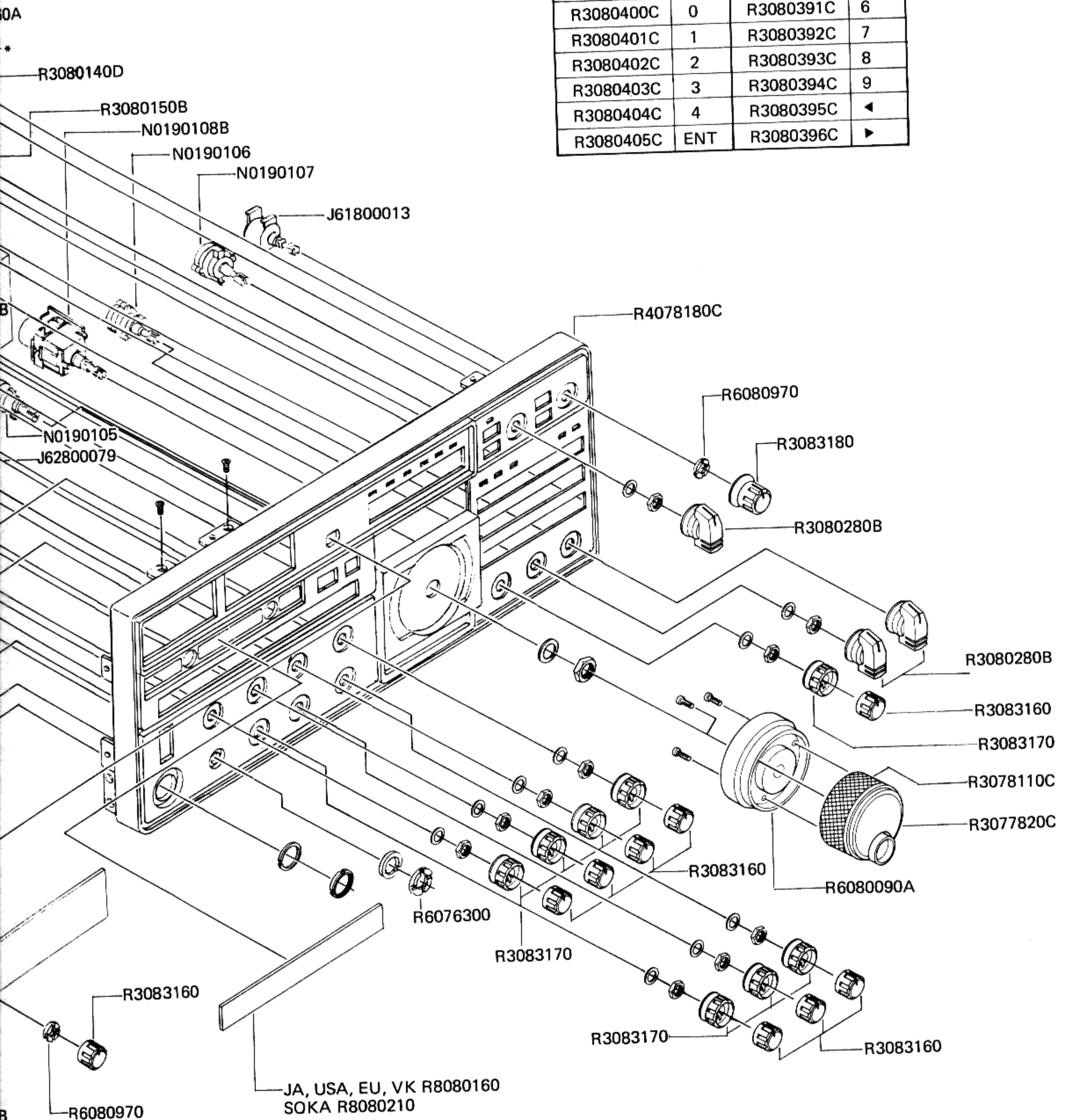

REAR PANEL EXPLODED VIEW 1

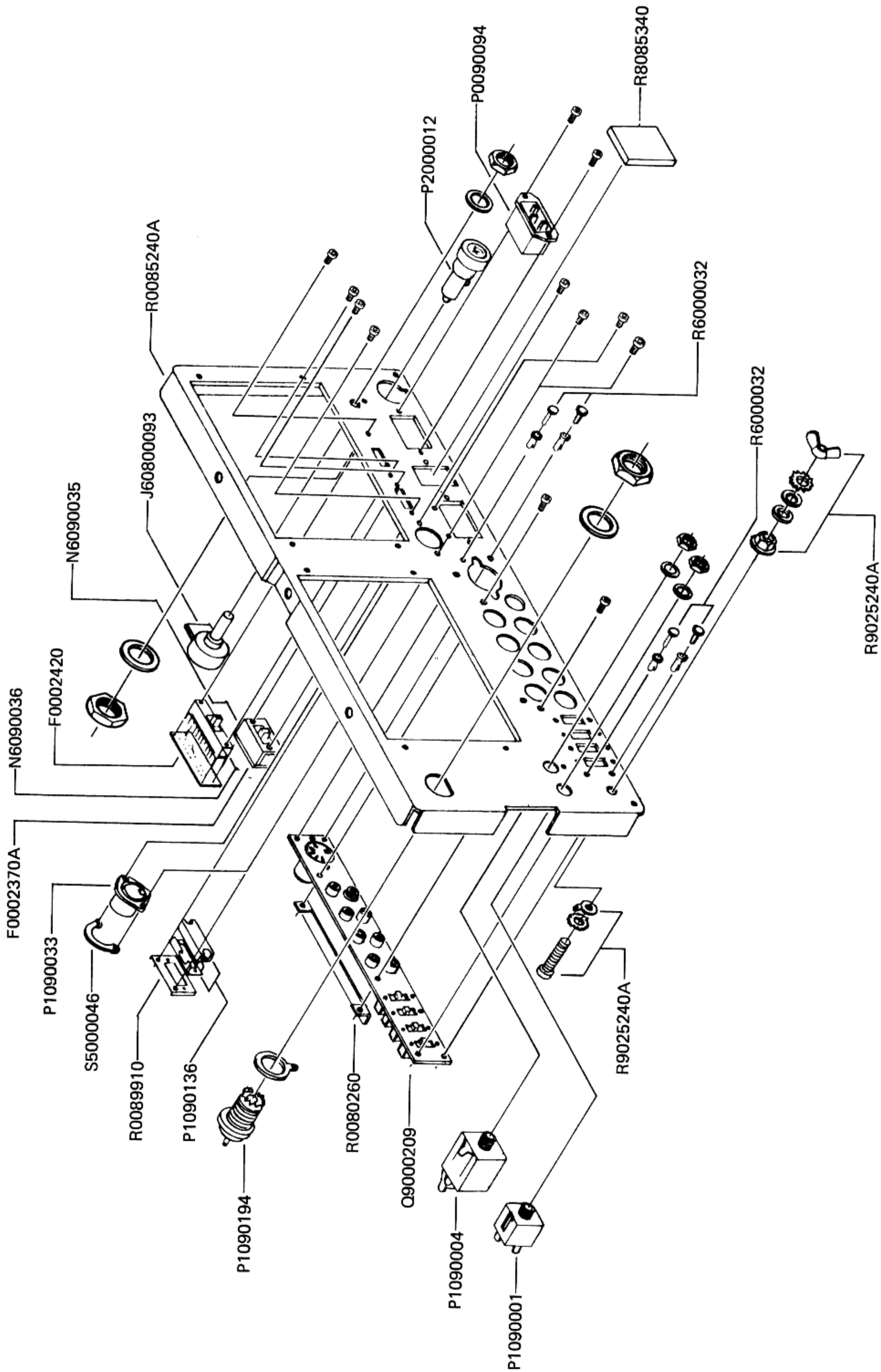

REAR PANEL EXPLODED VIEW 2

R0085240A

PARTS LIST

MAIN CHASSIS					METER
Symbol No.	Part No.	Description	M1	M0090015	IC, PO
		IC	M2	M0090016	S, ALC
Q3	G1090294	μ PC7808H			
		TRANSISTOR			SPEAKER
Q1	G3110120Y	2SA1012Y	SP1	M4090057	SE-92BF 4 Ω 3W
Q4	G3208560B	2SB856B			
Q2	G34088000	2SD880-O			
		DIODE	RL1	M1190049	RELAY
D1-6	G2090027	Si 1SS53			LR1A-12
		RESISTOR			SWITCH
R16,17	J20306569	Metallic film 1W 5.6 Ω	S1	N0190105	SRN2045 (Meter)
R1,2	J01275101	Carbon film 1/2W TJ 100 Ω	S2	N0190106	SRN2018 (Mode)
R6	J01245272	" " 1/4W TJ 2.7k Ω	S3	N0190107	SRN303C (Memory)
R7	J01245681	" " " " 680 Ω	S4	N2090031	EST157R (Power)
R8,12	J01245682	" " " " 6.8k Ω	S5		P/O UD-0113 (SEP/NOR)
R13	J01245105	" " " " 1M Ω	S6	Q9000209	Terminal Board (MARKER)
R5,15	J01245152	" " " TJ 1.5k Ω	S7		(KB TONE)
		POTENTIOMETER	S8		(LIN AMP)
VR1	J62800069	K16BA004C-10KAX2 10k Ω A/10k Ω A	S9	N6090035	SSB02302 (FSK Shift)
VR2	J62800070	K16BA1018-5M1222-20KC 500KB 20k Ω C/500k Ω B	S10	N6090036	SSB043036A (CW Pitch)
VR3	J62800075	K16BA004C-50KB-5KA 50k Ω B/5k Ω A	S11 (VR7)	N0190108B	SRS101Z
VR4	J62800072	K16BA004C-2KC-10KB 2k Ω C/10k Ω B	PB-2370A	F0002370A C023700A	Printed Circuit Board PCB with S11 (VR7), R5
VR5,6	J62800064	K16BA004C-10KB-10KA 10k Ω B/10k Ω A	PB-2420	F0002420 C024200A	Printed Circuit Board PCB with S10
VR7(with S11)					
VR8	J62800079	K16BA1-5M1112-500KC-10KA 500k Ω C/10k Ω A			
VR9	J61800013	K162B00B8J-20KBX2 20k Ω BX2	J1	P0090094	PA-125 (AC Power)
VR10	J60800093	K1611007AC-5KB 5k Ω B	J3	P1090134	SG7627 (Phones)
VR11	J50710503	V10K8-1-2-50KB 50k Ω B	J4	P1090001	SG7701 (Key 1)
		CAPACITOR	J5	P1090004	SG7814 (Key 2)
C1,3	K12329001	Ceramic 1.4KV 0.01 μ F (ECKDAL103PE)	J6	P1090033	D6-701B-00 (EXT CNTL)
C4,9-14,25,29	K13179008	" 50WV 0.01 μ F (DD106F103Z50V)	J8	P1090136	S-1628A-STA
C18,28	K13179009	" " 0.047 μ F (DD110F473Z50V)	J9	P1090194	FM-MR-M2' (Ant)
C20-23,27,30	K12171102	" " 0.001 μ F (DD104E102P50V)	J11	P0090158	FM-214-8SS (Mic)
C24	K02175470	" " CH47pF (DD106CH470J50V)	J12	P1090133	STR-01H
C16,17	K40129004	Electrolytic 16WV 10 μ F (16RE10)	J7		UC-0007 } P/O UD-0113
C26	K40129010	" " 2200 μ F (16RE2200)	J15-21	Q9000209	UA-0001 } Terminal Board
C19	K70120002	Tantalum 16WV 10 μ F (489D106X0016C1)	J22		UK-0002 }
C5	K21170002	Ceramic feed thru 50WV (ECK-Y1H-102WE) 0.001 μ F			
		INDUCTOR			
L2	L1190040	S4 1mH			
L3	L1190135	LAL04NA561K			
L5	L1190023	FL5H-220K 22 μ H		P2000013	FUSE HOLDER SN2059
L4	L1190090	LAL04NA102K 1mH	FH2	P2000025	H203
			FH3	P2000026	H202
					FUSE
				Q0000004	3A AC 10W Type
				Q0000005	5A AC 200-234VAC
				Q0000007	10A AC 100-117VAC
				Q0000031	13.6A DC
				Q0000032	6A DC
					BATTERY HOLDER
				P2000018	C3 (UM3X2)
					S1 SNAP with wire 500mm

R1075	J02245182	Carbon Film	1/4W SJ	1.8kΩ	C1113	K02172050	Ceramic	50WV CH 5pF
R1159,1163,1172*	J02245222	"	"	2.2kΩ	C1101,1103	K02173060	(DD104CH050C50V)	"
R1043	J01245392	"	TJ	3.9kΩ			"	6pF
R1001,1147,1149, 1161,1171,1174	J02245472	"	SJ	4.7kΩ	C1094,1096,1119	K02173070	(DD104CH060D50V)	7pF
R1005,1050,1091, 1093,1105,1153, 1167,1169	J02245562	"	"	5.6kΩ	C1108	K02173080	(DD104CH070D50V)	8pF
R1116,1121,1164	J02245682	"	"	6.8kΩ	C1112,1117	K02173090	(DD104CH080D50V)	9pF
R1048,1175*	J02245822	"	"	8.2kΩ	C1102	K02173100	(DD104CH090D50V)	10pF
R1002,1003,1010, 1018,1020,1022, 1024,1041,1062, 1063,1073,1074, 1082,1090,1097, 1098,1100,1101, 1107-1109, 1111,1112,1114, 1115,1129,1137, 1140,1142,1144, 1146,1148, 1155-1157, 1162,1168	J02245103	"	"	10kΩ	C1050,1052,1095, 1107	K02175120	(DD104CH100D50V)	12pF
					C1041,1045,1100	K02175180	(DD104CH120J50V)	18pF
					C1090	K02179008	(DD104CH180J50V)	20pF
					C1051,1146	K02179009	(DD104CH200J50V)	22pF
R1178	J01215103	"	1/8W TJ	10kΩ	C1042,1044,1086, 1248	K02175270	(DD104CH220J50V)	27pF
R1143	J01245103	"	1/4W TJ	10kΩ	C1032,1036,1167, 1168	K02175330	(DD104CH270J50V)	33pF
R1052	J02245123	"	SJ	12kΩ			(DD104CH330J50V)	39pF
	J02245183	"	"	18kΩ		K02175390	(DD105-257CH390J50V)	47pF
R1046,1158	J02245223	"	"	22kΩ	C1033,1035,1082	K02175470	(DD106CH470J50V)	56pF
R1179	J01215223	"	1/8W TJ	22kΩ	C1043	K02175560	(DD106CH560J50V)	68pF
R1006,1175	J02245333	"	1/4W "	33kΩ	C1065,1066,1144, 1236	K02175680	(DD107CH680J50V)	82pF
	J02245393	"	"	39kΩ	C1023,1024,1026, 1027,1201,1202	K02175820	(DD107CH820J50V)	100pF
R1192	J02245473	"	"	47kΩ		K02175101	(DD107CH101J50V)	110pF
R1152	J02245563	"	"	56kΩ	C1143	K02179020	(DD108CH111J50V)	120pF
R1102	J01245683	"	TJ	68kΩ	C1010,1013,1034	K02175121	(DD109CH121J50V)	130pF
R1127	J01245823	"	"	82kΩ	C1078,1147	K02179021	(DD109CH131J50V)	150pF
R1128	J02245823	"	SJ	82kΩ	C1014,1018	K02175151	(DD109CH151J50V)	180pF
R1072, 1083-1086, 1094,1096,1103, 1106,1118,1170, 1173	J02245104	"	"	100kΩ	C1015,1017,1145	K02179023	(DD110CH181J50V)	270pF
	J01245104	"	TJ	100kΩ	C1025	K02179027	(DD112CH271J50V)	470pF
R1119	J02245124	"	SJ	120kΩ	C1016	K30176471	Dipped Mica	560pF
R1088	J02245224	"	"	220kΩ	C1011,1012	K30176561	(Z8D471K05)	560pF
R1110	J02245474	"	"	470kΩ	C1069,1071	K30276182	(LCQ18561K05)	1800pF
R1026,1065,1113	J02245225	"	"	2.2MΩ	C1070	K30276102	(LCQ30182K5)	0.001μF
R1160	J02245335	"	"	3.3MΩ			(LCQ21102K5)	
R1089	J02245565	"	"	5.6MΩ	C1136,1138,1161, 1162,1166,1196, 1234,1235	K12171102	Ceramic	50WV E 0.001μF
		BLOCK RESISTOR					(DD104E102P50V)	
RB1001 1003	J40900029	EXB-P86-103		10kΩx6				0.01μF
RB1004	J40900049	EXB-P89-473		47kΩx8				
		POTENTIOMETER						
VR1003,1004	J51752502	RGS6-FAN		5kΩ				
VR1002	J51752203	"		20kΩ				
VR1005	J51752303	"		30kΩ				
VR1001	J51752503	"		50kΩ				
		LAMP FUSE						
F1001	Q1000010	BQ041-22803A						
		CAPACITOR						
C1118	K02179004	Ceramic	50WV CH 3pF	(DD104CH030C50V)	C1003,1009,1046, 1049,1053,1056, 1057,1059,1081, 1085,1089,1093, 1098,1099,1105, 1106,1110,1111, 1115,1116,1121 1241	K13179008	(DD106F103Z50V)	
	K02172040	"	"	4pF				
				(DD104CH040C50V)				

* 10W Type

C1122,1139,1142,1156-1160,1163-1165,1173,1177,1178,1181,1187-1190,1194,1210,1211,1216-1221,1230,1231,1233,1238	K13179008	Ceramic 50WV F 0.01 μ F (DD106F103Z50V)	L1026,1030	L1190111	FL4H-SR6K	5.6 μ H
			L1018	L1190013	FL4H-6R8K	6.8 μ H
			L1022,1024	L1190070	FL4H-8R2M	8.2 μ H
			L1013,1043,1046	L1190014	FL4H-100K	10 μ H
			L1021,1025	L1190015	FL4H-120K	12 μ H
			L1017,1019	L1190021	FL5H-180K	18 μ H
			L1016,1020	L1190023	FL5H-220K	22 μ H
			L1008	L1190073	FL5H-270K	27 μ H
C1005,1008,1019,1022,1028,1031,1037,1040,1058,1060,1062,1064,1068,1072,1074,1076,1077,1080,1084,1088,1092,1137,1140,1141,1149,1151,1152,1154,1169,1171,1172,1182,1183,1191-1193,1195,1197,1198,1200,1203,1204,1206,1208,1209,1214,1226,1237	K13179009	" " " 0.047 μ F (DD110F473Z50V)	L1011	L1190025	FL5H-330K	33 μ H
			L1012,1014	L1190027	FL5H-390K	39 μ H
			L1002,1004,1007,1009	L1190031	FL5H-680K	68 μ H
			L1050	L1190033	FL5H-820K	82 μ H
			L1006,1010,1035,1040,1060	L1190016	FL5H-101K	100 μ H
			L1045	L1190133	LAL04NA101K	100 μ H
			L1003	L1190018	FL5H-121K	120 μ H
			L1031,1036,1047,1051,1068	L1190017	FL5H-102K	1mH
			L1039,1061,1063,	L1190090	LAL04NA102K	1mH
			L1001,1005,1048,1064,1067	L1190040	S-4	1mH
C1006	K19149021	Semiconductor Ceramic 25WV 0.047 μ F (UAT08X473KL45AE)		L1190142	LAL04NA5R6K	5.6 μ H
C1185,1239	K19149025	" 25WV 0.1 μ F (UAT13X104KL46AE)		L9190016	7mm Shield Case	
C1223,1224	K50177473	Mylar 50WV 0.047 μ F (50F2U473M)				
C1227,1228	K50177104	" " 0.1 μ F (50F2U104M)				TRANSFORMER
C1229	K70167224	Tantalum 35WV 0.22 μ F (CS15E1VR22M)	T1001,1002	L0021362		
			T1027	L0020789A		
C1174	K70127225	" 16WV 2.2 μ F (CS15E1C2R2M)	T1003,1004	L0020899	RF COIL	160m
			T1005,1006	L0020781	"	80m
C1083	K70120008	" " 22 μ F (489D226X0016D1)	T1007,1008	L0020782	"	40m
			T1009,1010	L0020892	"	30m
C1184	K40179010	Electrolytic 50WV 0.47 μ F (50RER47)	T1011,1012	L0020783	"	20m
			T1013,1014	L0020890	"	17m
C1007,1061,1073,1075,1148,1150,1153,1199,1205	K40179013	" " 1 μ F (50RE1)	T1015,1016	L0020784	"	15m
			T1017,1018	L0020785	"	12m
C1063,1155,1170,1179,1180,1186,1207,1222,1225	K40149008	" 25WV 10 μ F (25RE10)	T1019,1020	L0020893	"	10m
			T1028,1033,1034	L0020788A		
C1175	K40129012	" 16WV 10 μ F (ECEA1CK100)	T1029	L0021223		
			T1030	L0021224		
C1001,1004,1020,1021,1029,1030,1038,1039,1047,1048,1054,1055,1079,1087,1091,1097,1104,1109,1114,1120,1215	K40129016	" " 22 μ F (16RE22)	T1031,1032	L0021225		
C1002	K40129007	Electrolytic 16WV 100 μ F (16RE100)				RELAY
			RL1001	M1190027	G2V-2	9V
						SWITCH
			S1001	N0190109	SBU2044N(10)-R15	
						TERMINAL
L1032,1037,1044	L0021221	LPF COIL 0.17 μ H		Q5000050	TP Terminal	TP-K
L1038	L0021222	" 0.24 μ H		Q5000011	Wrapping Terminal	C
	L0021220	" 0.32 μ H				
L1052	L0021245	" 0.42 μ H				
L1041	L1190005	FL4H-1R0M 1 μ H				CONNECTOR
L1028	L1190008	FL4H-2R2M 2.2 μ H	J1001-1005	P1090210	TMP-JV	
L1023,1027,1029,1066	L1190010	FL4H-3R9K 3.9 μ H	J1012,1015,1017,1018	P0090218	5045-02A	
			J1007,1016	P0090220	5045-04A	
L1033,1034,1042,1049,1053-1059	L1190011	FL4H-4R7K 4.7 μ H	J1010,1011,1014	P0090221	5045-05A	

MIL-STD-883C METHOD 2000

R2194	J02245271	Carbon film	1/4W SJ	270Ω	R2142,2166,2173, 2175,2210,2215, 2225,2251	J02245104	Carbon film	1/4W SJ	100kΩ	
R2038,2221,2244	J02245331	" "	" "	330Ω			" "	" "	120kΩ	
R2245	J00215331	" "	1/8W VJ	330Ω	R2106,2168	J02245124	" "	" "	150kΩ	
R2001,2007,2008, 2016,2017,2024, 2046,2094,2118, 2198, 2201-2203, 2209,2236	J02245471	" "	1/4W SJ	470Ω	R2041,2110,2112, 2167	J02245154	" "	" "	180kΩ	
					R2095	J02245184	" "	" "	330kΩ	
					R2051	J02245334	" "	" "	560kΩ	
R2012,2062,2072, 2079,2154,2155, 2222	J02245561	" "	" SJ	560Ω	R2120,2121,2124	J02245564	" "	" "	680kΩ	
					R2044,2228,2229,	J02245684	" "	" "	1MΩ	
R2002,2179,2196, 2252	J02245681	" "	" SJ	680Ω		J02245105	" "	" "	1.5MΩ	
					R2074,2084,2227	J02245155	" "	" "	2.2MΩ	
R2180,2239	J02245821	" "	" "	820Ω		J02245225	" "	" "		
R2069,2096,2098, 2108,2136,2146, 2149,2150,2156, 2184,2185,2212, 2223,2226	J02245102	" "	" "	1kΩ			POTENTIOMETER			
							VR2001	J51752102	RGS6-FAN	1KB
R2056,2153	J02245122	" "	" "	1.2kΩ			VR2002	J51752502	"	5KB
R2045,2115,2188, 2195	J02245152	" "	" "	1.5kΩ			VR2004,2006, 2007	J51752103	"	10KB
R2192	J02245182	" "	" "	1.8kΩ			VR2003,2005, 2008	J51752503	"	50KB
R2014,2015,2097, 2099,2100,2127, 2139,2234	J02245222	" "	" "	2.2kΩ			VR2010	J51752104	"	100KB
							VR2009	J51752105	"	1MB
R2068,2109,2111, 2113,2130	J02245332	" "	" "	3.3kΩ						
R2028,2030,2031, 2033,2034,2036, 2037,2240	J02245392	" "	" "	3.9kΩ					BLOCK RESISTOR	
							RB2001	J40900024	RK1/16B5R10K	10Kx5
R2085,2125,2126, 2132,2135,2147, 2183,2207	J02245472	" "	" "	4.7kΩ					CAPACITOR	
R2070,2102,2103, 2114,2137,2224	J02245562	" "	" "	5.6kΩ			C2130,2171	K00172030	Ceramic disc	50WV SL 3pF (DD104SL030C50V)
R2128,2131,2190, 2218	J02245682	" "	" "	6.8kΩ			C2138	K06172030	"	" " " UJ 3pF (DD104UJ030C50V)
R2191	J01245682	" "	" TJ	6.8kΩ			C2133,2174,2184, 2210,2220,2221	K00173100	"	" " " SL 10pF (DD104SL100D50V)
R2050	J02245822	" "	" SJ	8.2kΩ			C2148	K00175150	"	" " " " 15pF (DD104SL150J50V)
R2003,2018,2020, 2022,2023,2039, 2049,2052,2058, 2076,2089,2104, 2117,2122,2141, 2144,2163,2171, 2174,2186,2197, 2200,2208,2214, 2230-2233	J02245103	" "	" "	10kΩ			C2147	K00175330	"	" " " " 33pF (DD104SL330J50V)
R2119,2241,2242	J01245103	" "	" TJ	10kΩ			C2002,2115	K00175470	"	" " " " 47pF (DD104SL470J50V)
R2009,2086,2123, 2145,2211,2247	J02245153	" "	" SJ	15kΩ			C2213	K02175560	"	" " " " CH 56pF (DD106CH560J50V)
R2073	J01245183	" "	" TJ	18kΩ			C2010,2019,2020, 2047,2057,2063, 2064,2079,2091, 2092,2113,2136, 2175	K00175101	"	" " " " SL 100pF (DD105SL101J50V)
R2091,2105,2134, 2148,2182	J02245223	" "	" SJ	22kΩ			C2134	K00175221	"	" " " " 220pF (DD107SL221J50V)
R2139	J01245223	" "	" TJ	22kΩ			C2139,2140,2142	K06179018	"	" " " " UJ 330pF (DD110UJ331J50V)
R2143,2151,2172, 2248	J02245273	" "	" SJ	27kΩ			C2003,2066,2067, 2074,2081,2083, 2201,2219	K12171102	"	" " " " E 0.001μF (DD104E102P50V)
R2161,2169,2170	J02245333	" "	" "	33kΩ			C2001,2004, 2006-2008, 2011,2012, 2015-2018, 2021,2022,2026, 2028,2030,2032, 2034,2036,2039, 2042,2048,2052, 2053,2055,2061, 2075,2080,2082	K13179008	"	" " " " F 0.01μF (DD106F103Z50V)
R2065,2140,2157	J02245393	" "	" "	39kΩ						
R2021,2057,2107	J02245473	" "	" "	47kΩ						
R2083,2116	J02245563	" "	" "	56kΩ						
R2064	J02245683	" "	" "	68kΩ						
R2053,2177	J02245823	" "	" "	82kΩ						
R2004,2005,2011, 2019,2040,2054, 2061,2071,2077, 2080,2081,2084, 2087,2088,2090	J02245104	" "	" "	100kΩ						

00kΩ
20kΩ
50kΩ
80kΩ
30kΩ
60kΩ
80kΩ
MΩ
1.5MΩ
2.2MΩ
10Kx5
3pF
J 3pF
L 10pF
15pF
33pF
47pF
H 56pF
L 100pF
220pF
J 330pF
E 0.001μF
F 0.01μF

C2093,2122,2126,2127,2129,2131,2137,2141,2143,2144,2149-2157,2159,2167-2170,2172,2176,2178-2183,2185,2186-2200,2202,2203,2205-2209,2214-2217	K13179008	Ceramic disc 50WV F 0.01μF (DD106F103Z50V)	C2014,2073,2078,2084,2086,2087,2118,2119,2121,2161,2212	K40149008	Electrolytic 25WV 10μF (25RE10)
			C2099,2104,2211	K40129016	" 16WV 22μF (16RE22)
			C2177	K40129007	" " 100μF (16RE100)
					TRIMMER CAPACITOR
C2005,2009,2023,2025,2027,2029,2031,2033,2035,2037,2038,2040,2043,2045,2046,2051,2054,2056,2058,2059,2065,2068,2070-2072,2088 2090,2094,2120,2123,2141,2145,2146,2158,2162,2204	K13179009	" " " " 0.047μF (DD110F473Z50V)	TC2001	K91000093	CTZ51F 30pF
					THERMISTOR
			TH2001	G9090001	SDT-250
			TH2002	G9090012	SDT-500
					INDUCTOR
			L2010-2012,2015	L1190014	FL4H-100K 10μH
			L2001	L1190134	S4-180K 18μH
			L2008	L1190023	FL5H-220K 22μH
C2105	K19149001	Semiconductor Ceramic 25WV 0.001μF (UAT04X102K-L05AE)	L2009,2016-2022,2024	L1190016	FL5H-101K 100μH
C2112,2114,2117,2125,2128,2132,2165,2166,2173	K19149013	" " " " 0.01μF (UAT05X103K-L05AE)	L2002,2004-2007,2013,2023,2025,2026,2027	L1190017	FL5H-102K 1mH
C2106,2107	K19149017	" " " " 0.022μF (UAT06X223K-L45AE)			
C2108	K19149019	" " " " 0.033μF (UAT08X333K-L45AE)	L2003	L0021196	
C2024,2041,2044,2062,2095-2098,2100-2103,2116	K19149021	" " " " 0.047μF (UAT08X473K-L45AE)	L2014	L0021227	
					TRANSFORMER
			T2003-2005,2011,2012,2015-2017	L0020140	
C2013,2041	K19149025	" " " " 0.1μF (UAT13X104K-L46AE)	T2014	L0020141	
C2050	K50177102	Mylar 50WV 0.001μF (S0F2U102M)	T2008	L0020421	
C2069	K50177222	" " " " 0.0022μF (S0F2U222M)	T2007,2009	L0020420	
C2077	K50177223	" " " " 0.022μF (S0F2U223M)	T2006,2010	L0020422	
C2160	K50177104	" " " " 0.1μF (S0F2U104M)	T2001,2020	L0021225	
C2085	K50176224	" " " " 0.22μF (MRS50V224K)	T2002	L0021231	
C2049	K51176102	Styrol " 0.001μF (S0SU102K)	T2013	L0021233	
C2060	K70167334	Tantalum 35WV 0.33μF (CS15E1VR33M)	T2018	L0021087B	
C2076	K70147105	" 25WV 1μF (CS15E1E010M)	T2019	L0020209	
C2163	K70127225	" 16WV 2.2μF (CS15E1C2R2M)			
C2124	K70120002	" " 10μF (489D106X0016C1)			CONNECTOR
C2135	K70120008	" " 22μF (489D226X0016D1)	J2003,2004,2007	P0090218	5045-02A
C2109	K40179016	Electrolytic 50WV 0.1μF (S0RE0R1)	J2005	P0090219	5045-03A
C2111	K40179013	" " 1μF (S0RE1)	J2009	P0090220	5045-04A
C2218	K40179012	" " 4.7μF (S0RE4R7)	J2001,2006	P0090221	5045-05A
			J2002	P0090222	5045-06A
			J2008	P0090226	5045-10A
			J2010-2016	P1090210	TMPJV
				Q5000036	TP-G
				P0090183	SMF Connector RT-01T-1.0B

MIL-STD-883C METHOD 2000

AF UNIT				R3194	J02245820	Carbon film	1/4W SJ	82Ω
Symbol No.	Part No.	Description		R3008	J01245101	" "	" "	TJ 100Ω
PB-2375A	F0002375A	Printed Circuit Board		R3015,3027,3035, 3039,3042,3076, 3085,3087,3118, 3142,3158,3159, 3193	J02245101	"	"	SI 100Ω
		C023750A	PCB with Components					
			FET	R3177	J02245121	"	"	120Ω
Q3010	G3801070C		2SK107-3	R3047	J02245151	"	"	150Ω
Q3021	G4800730G		3SK73GR	R3026,3030,3058, 3163,3164,3200	J02245221	"	"	220Ω
				R3156,3162	J02245271	"	"	270Ω
				R3152,3178	J02245331	"	"	330Ω
			IC	R3009,3056,3060	J02245391	"	"	390Ω
Q3026	G1090248		AN6551	R3040,3048,3151, 3175	J02245471	"	"	470Ω
Q3009	G1090340		MC1496P					
Q3019	G1090068		MC14011B					
Q3023	G1090257		MC14066B	R3057,3061,3198	J02245561	"	"	560Ω
Q3028	G1090284		μPC2002V	R3041,3116	J02245681	"	"	680Ω
Q3029	G1090084		μPC78L05	R3001-3003, 3010,3059,3068, 3077,3080,3157, 3168,3173,3176	J02245821	"	"	820Ω
Q3037	G1090118		NJM78L09A					
Q3038	G2090220		ND487R1-3R					
				R3019,3021,3036, 3063,3069,3071, 3073,3075,3117, 3122,3165,3169, 3174,3182,3187, 3202	J02245102	"	"	1kΩ
			TRANSISTOR					
Q3018	G3105641		2SA564AR					
Q3031,3033,3035	G3107331P		2SA733AP					
Q3032,3034	G3109500Y		2SA950Y					
Q3030,3036	G3207740		2SB774	R3079	J02245122	"	"	1.2k
Q3001	G3307320G		2SC732GR	R3006,3115,3140	J02245152	"	"	1.5k
Q3002-3008, 3011,3012,3015, 3016,3024,3025, 3027	G3309451		2SC945AP	R3083,3111,3112, 3123,3128,3132, 3144,3216,3218, 3227	J02245222	"	"	2.2k
Q3013,3014,3017, 3020	G3318150G		2SC1815GR	R3018,3110,3133	J02245272	"	"	2.7k
Q3022	G3318150Y		2SC1815Y	R3007,3014,3108, 3127,3185	J02245332	"	"	3.3k
				R3220	J02245392	"	"	3.9k
				R3066,3078,3086, 3091,3092,3130, 3131,3166	J02245472	"	"	4.7k
			DIODE					
D3025,3029	G2090093	Ge	1N270					
D3002,3003	G2001880F	"	1S188FM	R3028,3107,3209	J02245562	"	"	5.6k
D3001, 3006-3024, 3026,3030, 3032, 3035-3037, 3039-3043, 3045,3046	G2090027	Si	1SS53	R3215,3217,3219	J02245682	"	"	6.8k
				R3070,3114,3146, 3167,3179,3180	J02245822	"	"	8.2k
D3004	G2090180	Varactor	FC53M-5	R3017,3021,3023, 3034,3038,3064, 3072,3074,3121, 3135,3137,3161, 3170,3192,3203, 3208,3210-3214, 3223	J02245103	"	"	10k
D3005	G9090005	Varistor	MV103					
D3028,3031	G2090188	Zener	HZ5C-1	R3225,3226	J01215103	"	"	1/8W TJ 10k
D3044	G2090154	"	RD7.5EB-1	R3013,3084,3139, 3160,3191,3195	J02245123	"	"	1/4W SJ 12k
				R3224	J01215123	"	"	1/8W TJ 12k
X3001	H0102472		HC-18/T3P 8987.5kHz	R3004,3082,3124, 3197,3204	J02245153	"	"	1/4W SJ 15k
				R3094,3184,3199	J02245183	"	"	18k
				R3033,3113,3120, 3126,3129,3134, 3136	J02245223	"	"	20k
			RESISTOR					
R3206,3207	J10276129	Carbon composition 1/2W GK 1.2Ω		R3012,3037,3051, 3065	J02245273	"	"	20k
R3201	J02245229	"	film 1/4W SJ 2.2Ω	R3016,3029,3106, 3138	J02245333	"	"	30k
R3045,3046	J02245829	"	" " " 8.2Ω					
R3043,3044	J02245120	"	" " " 12Ω					
R3109	J02245270	"	" " " 27Ω	R3005,3125	J02245393	"	"	30k
R3020,3186	J02245330	"	" " " 33Ω	R3031,3081,3090, 3150,3171,3188	J02245473	"	"	40k
R3067,3149	J02245560	"	" " " 56Ω					

32Ω
100Ω
100Ω
120Ω
150Ω
220Ω
270Ω
330Ω
390Ω
470Ω
560Ω
680Ω
820Ω
1kΩ
1.2kΩ
1.5kΩ
2.2kΩ
2.7kΩ
3.3kΩ
3.9kΩ
4.7kΩ
5.6kΩ
6.8kΩ
8.2kΩ
10kΩ
10kΩ
12kΩ
12kΩ
15kΩ
18kΩ
22kΩ
27kΩ
33kΩ
39kΩ
47kΩ

R3095,3183	J02245563	Carbon film 1/4W SJ 56kΩ	C3075,3076,3078,3081,3082,3084,3086,3088,3101,3106-3108,3110,3115,3118,3119,3122	K40179013	Electrolytic 50WV 1μF
R3089	J02245683	" " " " 68kΩ			
R3011,3024,3099	J02245823	" " " " 82kΩ			
R3022,3093,3098,3196	J02245104	" " " " 100kΩ			
R3181	J02245184	" " " " 180kΩ	C3060	K40179009	" " 2.2μF (50RE2R2)
R3088	J02245224	" " " " 220kΩ			
R3189	J02245274	" " " " 270kΩ	C3062,3072	K40179012	" " 4.7μF (50RE4R7)
R3190	J02245474	" " " " 470kΩ			
R3141,3145	J02245105	" " " " 1MΩ	C3109,3140	K40129004	" 16WV 10μF (16RE10)
R3143	J02245335	" " " " 3.3MΩ			
			C3005,3011-3013,3015,3016,3023,3057,3080,3083,3085,3116,3117,3120	K40149008	" 25WV 10μF (25RE10)
		POTENTIOMETER			
VR3001	J51752503	RGS6-FAN 50kΩ			
VR3005	J51752301	RGS6-FAN 300Ω			
VR3003	J51752202	RGS6-FAN 2kΩ	C3047,3063	K40129016	" 16WV 22μF (16RE22)
VR3004	J51724503	PN822H503H 50kΩ			
			C3001,3008,3014,3059,3065,3074,3077,3079,3133	K40129008	" 33μF (16RE33)
		BLOCK RESISTOR			
RB3001	J40900031	EXB-P85-472 4.7KX5	C3006	K40109002	" 10WV 47μF (10RE47)
			C3058	K40129002	" 16WV 47μF (16RE47)
		CAPACITOR			
C3025	K06172040	Ceramic Disc 50WV UJ 4pF (ECCD1H040CU)	C3010,3017,3067,3105	K40109001	" 10WV 100μF (10RE101)
C3040	K02173100	" " " CH 10pF (DD104CH100D50V02)	C3124,3128	K40129006	" 16WV 470μF (16RE470)
C3029	K02179009	" " " " 22pF (DD104CH220J50V02)	C3123	K40129021	" " 1000μF (16R102S 13x16)
C3126	K00175330	" " " " SL 33pF (DD104SL330J50V02)	C3007,3104	K50177102	Mylar 50WV 0.001μF (50F2U102M)
C3093	K00175470	" " " " 47pF (DD104SL470J50V02)	C3002,3003	K50177222	" " 0.0022μF (50F2U222M)
C3027	K02179023	" " " " CH 180pF (DD110CH181J50V02)		K50177332	" " 0.0033μF (50F2U332M)
C3030	K06175181	" " " " UJ 180pF (ECCD1H181U2)	C3103	K50177682	" " 0.0068μF (50F2U682M)
C3134,3137,3138	K00175221	" " " " SL 220pF (DD104SL221J50V02)	C3102,3111-3114	K50177153	" " 0.015μF (50F2U153M)
C3142	K00175331	" " " " " 330pF (DD107SL331J50V02)	C3100	K50177223	" " 0.022μF (50F2U223M)
C3141	K00179054	" " " " " 470pF (DD109SL471J50V02)	C3019,3020,3039,3130	K50177473	" " 0.047μF (50F2U473M)
C3021,3069,3073,3090,3127,3139,	K12171102	" " " " E 0.001μF (DD104E102P50V02)	C3129	K50177104	" " 0.1μF (50F2U104M)
C3018,3022,3028,3031-3037,3041-3046,3048,3050,3051,3052,3056,3068,3087,3121	K13179008	" " " " F 0.01μF (DD106F103Z50V02)	C3091	K70167225	Tantalum " 2.2μF (CS15E1V2R2M)
			C3136	K70120002	" 16WV 10μF (489D106X0016C1)
C3094-3099	K13179009	" " " " F 0.047μF (DD110F473Z50V02)			INDUCTOR
C3089	K19149021	Semiconductor Ceramic 25WV 0.047μF (UAT08X473K-L45AE)	L3003	L1190105	FL3H-1R0M 1μH
			L3002	L1190038	FL5H271K 270μH
			L3001	L1190102	S-104K 100mH
C3125	K19149025	" " " " 0.1μF (UAT10X104K-L46AE)			
C3038,3131	K40129018	Electrolytic 16WV 0.33μF (AL16WV0.33MFM)			TRANSFORMER
C3064	K40179010	" 50WV 0.47μF (50RE0R47)	T3001	L0021230	
			T3002	L0021232	
			T3003	L0190026	R12-7949C
C3004,3049,3061,3066,3070,3071	K40179013	" " " 1μF	T3004	L0020788A	
			T3005	L0020319	

		CONNECTOR	R4066	J02245180	Carbon film	1/4W SJ	18Ω
J3001,3002,3004	P0090218	5045-02A	R4054	J02245270	" "	" "	27Ω
J3003,3005,3006, 3012	P0090219	5045-03A	R4067	J01245330	" "	" TJ	33Ω
			R4034	J02245390	" "	" SJ	39Ω
J3010,3014	P0090220	5045-04A	R4065,4080	J02245560	" "	" "	56Ω
J3008,3009,3013	P0090221	5045-05A	R4072	J01245560	" "	" TJ	56Ω
J3011	P0090222	5045-06A	R4083	J02245680	" "	" SJ	68Ω
J3007	P0090224	5045-08A	R4006,4012,4016, 4020,4023,4027, 4031,4039,4049, 4059,4075,4086, 4088	J02245101	" "	" "	100Ω
J3020,3021	P0090183	RT-01T-1.0B					
J3015-3019	P1090210	TMPJV					
			R4033,4052	J01245101	" "	" TJ	100Ω
	Q5000049	TP-J	R4064	J02245121	" "	" SJ	120Ω
	Q5000050	TP-K	R4003,4058	J02245151	" "	" "	150Ω
			R4073,4074,4081, 4082	J02245181	" "	" "	180Ω
	R0079780A	HEAT SINK	R4096	J00215221	" "	1/8W VJ	220Ω
			R4063	J02245271	" "	1/4W SJ	270Ω
			R4013,4017,4021, 4048,4051,4055, 4079,4089,4095	J02245331	" "	" "	330Ω
PLL/VCO UNIT							
Symbol No.	Part No.	Description					
PB-2372A	F0002372A	PLL PC Board					
	C023720A	PCB with components					
PB-2371A	F0002371A	VCO PC Board	R4050	J02245391	" "	" SJ	390Ω
	C023720A	PCB with component		J02245471	" "	" SJ	470Ω
	C023720B	PLL/VCO UNIT Assembly	R4022,4024	J02245561	" "	" "	560Ω
			R4053,4071	J02245821	" "	" "	820Ω
			R4040,4042,4043, 4046	J02245102	" "	" "	1kΩ
***** PLL UNIT *****							
Symbol No.	Part No.	Description					
		IC	R4004,4036,4097	J02245152	" "	" "	1.5kΩ
Q4006,4022	G1090296	HD10551	R4077	J02745222	" "	" "	2.2kΩ
Q4011,4014	G1090153	MB8718	R4026	J02245332	" "	" "	3.3kΩ
Q4016	G1090104	MC14027B	R4002	J02245392	" "	" "	3.9kΩ
Q4015	G1090108	MC14518B	R4038	J02245682	" "	" "	6.8kΩ
Q4004	G1090118	NJM78L09A	R4098	J01245822	" "	" TJ	8.2kΩ
Q4018-4020	G1090034	SN74LS90N	R4001,4099	J01245103	" "	" "	10kΩ
Q4013,4028,4030	G1090062	SN76514N	R4005,4007,4008, 4015,4019,4025, 4044,4045,4057, 4069,4087, 4091-4093	J02245103	" "	" SJ	10kΩ
Q4010	G1090299	μPC7805H					
		TRANSISTOR	R4078,4085,4090	J02245153	" "	" "	15kΩ
Q4012,4017,4021, 4023,4026,4027	G3303800Y	2SC380TM-Y	R4056	J02245183	" "	" "	18kΩ
			R4009	J02245273	" "	" "	27kΩ
Q4003,4005,4007	G3305350A	2SC535A	R4014,4018,4037	J02245333	" "	" "	33kΩ
Q4025	G3305350C	2SC535C	R4076,4084	J02245393	" "	" "	39kΩ
Q4008,4031	G3318150G	2SC1815GR	R4060	J02245823	" "	" "	82kΩ
Q4024,4029	G3319230R	2SC1923R	R4011, 4028-4030, 4041,4047	J02245104	" "	" "	100kΩ
Q4001	G3090005	MPSA13					
			R4032	J02245124	" "	" "	120kΩ
		FET					
Q4002	G3090035	2SK19TMGR					
Q4009	G4800730G	3SK73GR					
		DIODE					
	G2090029	Ge	1N60				
D4003	G2090027	Si	1SS53				
D4001	G2090161	Varactor	1SV55	TH4001	G9090008		
		CRYSTAL					
X4001	H0102459	HC-18/U	38.0675MHz	C4006,4013	K02179003	Ceramic	50WV CK 2pF (DD104CK020C50V)
				C4062,4078	K02179004	"	" " " 3pF (DD104CK030C50V)
		RESISTOR					
R4070	J02245100	Carbon film	1/4W SJ	10Ω			

112001 112002 112003 112004 112005 112006 112007 112008 112009 112010 112011 112012 112013 112014 112015 112016 112017 112018 112019 112020 112021 112022 112023 112024 112025 112026 112027 112028 112029 112030 112031 112032 112033 112034 112035 112036 112037 112038 112039 112040 112041 112042 112043 112044 112045 112046 112047 112048 112049 112050 112051 112052 112053 112054 112055 112056 112057 112058 112059 112060 112061 112062 112063 112064 112065 112066 112067 112068 112069 112070 112071 112072 112073 112074 112075 112076 112077 112078 112079 112080 112081 112082 112083 112084 112085 112086 112087 112088 112089 112090 112091 112092 112093 112094 112095 112096 112097 112098 112099 112100

18Ω
27Ω
33Ω
39Ω
56Ω
56Ω
68Ω
100Ω
100Ω
120Ω
150Ω
180Ω
220Ω
270Ω
330Ω
390Ω
470Ω
560Ω
820Ω
1kΩ
1.5kΩ
2.2kΩ
3.3kΩ
3.9kΩ
6.8kΩ
8.2kΩ
10kΩ
10kΩ
15kΩ
18kΩ
27kΩ
33kΩ
39kΩ
82kΩ
100kΩ
120kΩ
10Kx8
10Kx7
CK2pF
3pF

C4008,4090	K02172050	Ceramic 50WV CH 5pF (DD104CH050C50V02)	C4043,4046,4127	K50177102	Mylar 50WV 0.001μF (50F2U102M)
C4119	K00173060	" " SL 6pF (DD104SL060D50V02)	C4004	K50177223	" " 0.022μF (50F2U223M)
C4012,4077	K02173080	" " CH 8pF (DD104CH080D50V02)	C4003,	K50177473	" " 0.047μF (50F2U473M)
C4021,4032	K00173080	" " SL 8pF (DD104SL080 50V02)	C4015	K50177104	" " 0.1μF (50F2U104M)
	K02175120	" " CH 12pF (DD104CH120J50V02)	C4038	K40129018	Electrolytic 16WV 0.33μF (AL16WV0.33MFM)
C4091	K02179007	" " " 16pF (DD104CH160J50V02)	C4002,4023,4039, 4040,4045,4055	K40129004	" " 10μF (16RE10)
C4007,4104	K02175180	" " " 18pF (DD104CH180J50V02)	C4053,4075	K40109002	" 10WV 47μF (10RE47)
C4026,4029	K02179008	" " " 20pF (DD104CH200J50V02)	C4057	K40129002	" 16WV 47μF (16RE47)
	K05175220	" " RH 22pF (DD104RH220J50V02)	C4074	K70167684	Tantalum 35WV 0.68μF (CS15E1VR68M)
C4009,4094,4121	K02179009	" " CH 22pF (DD104CH220J50V02)	C4001	K54200001	Polyester film 100WV 1μF (B32561A1105J)
C4118	K00175220	" " SL 22pF (DD104SL220J50V02)			
C4089	K02179011	" " CH 27pF (DD105CH270 50V02)	TC4001	K91000055	TRIMMER CAPACITOR ECV-1ZW06X53N
	K06179006	" " UJ 30pF (DD104UJ300J50V02)			
C4011,4025,4031, 4092	K02179012	" " CH 30pF (DD105CH300J50V02)	L4014	L0020898	INDUCTOR 0.39μH
C4027,4028	K02175390	" " " 39pF (DD105-257CH390J50V02)	L4017	L0021245	0.420μH
C4084,4088	K02179015	" " " 43pF (DD106CH430J50V02)	L4016	L0021246	0.576μH
C4102	K02175470	" " " 47pF (DD106CH470J50V02)	L4015	L0021244	0.677μH
C4087	K02179017	" " " 62pF (DD106CH620J50V02)	L4002	L1190004	FL4H-R68M 0.68μH
C4086	K02179018	" " " 75pF (DD107CH750J50V02)	L4003,4022	L1190006	FL4H-1R2M 1.2μH
C4061	K00175101	" " SL 100pF (DD105SL101J50V02)	L4024	L1190008	FL4H-2R2M 2.2μH
C4085,4113	K02179020	" " CH 110pF (DD108CH111J50V02)	L4012,4013	L1190112	FL4H-120K 12μH
C4016,4017	K30276241	Dipped Mica 500WV 240pF (LCQ17241K5)	L4005-4007	L1190019	FL5H-150K 15μH
C4083	K02179027	Ceramic 50WV CH 270pF (DD112CH271J50V02)	L4021	L1190016	FL5H-101K 100μH
C4112,4114	K30276751	Dipped Mica 500WV 750pF (LCQ18751K5)	L4010	L1190020	FL5H-151K 150μH
C4059,4092,4080, 4129-4132	K12171102	Ceramic 50WV E 0.001μF (DD104E102P50V02)	L4009,4019,4020, 4023	L1190038	FL5H-271K 270μH
C4005,4010,4014, 4018-4020, 4024,4030, 4033-4037, 4041,4044, 4048-4052, 4067,4079,4081, 4082,4093, 4095 4101, 4103, 4105-4111, 4115-4117, 4122-4126,4128	K13179008	" " F 0.01μF (DD106F103Z50V02)	L4008	L1190017	FL5H102K 1mH
			L4004	L2030068	
					TRANSFORMER
			T4001,4002	L0021233	
			T4003-4005,4007	L0021234	
			T4006	L0020209	
				L9190016	Shield Case
					CONNECTOR
			J4001,4008,4009	P1090255	TMP-JA
			J4002,4006	P1090210	TMP-JV
			J4003	P0090218	5045-02A
			J4004,4007	P0090183	RT-01T-1.0B
			J4005	P0090219	5045-03A
			J4010	P0090224	5045-08A
			J4011	P0090223	5045-07A
C4058,4076	K13170223	Ceramic 50WV 0.022μF (DD109F223Z50V02)			
C4054,4056,4060, 4063-4066, 4068,4073	K13179009	" " 0.047μF (DD110F473Z50V02)			

TP4001	P0090183	RT-01T-1.0B	R5031,5032,5038, 5039,5045,5046, 5052,5053,5059, 5060,5066,5067, 5073	J02245103	Carbon film 1/4W SJ 10kΩ
TP4002	Q5000050	TP-K			
TP4003	Q9000192	30F-T0-220			
			R5072	J02245223	" " " " 22kΩ
			R5007,5016,5020, 5030,5035,5044, 5049,5058,5063	J02245563	" " " " 56kΩ
			R5077,5078,5080, 5084	J02245104	" " " " 100kΩ
			R5008,5009,5013, 5014,5021,5022, 5027,5028,5036, 5037,5041,5042, 5050,5051,5055, 5056,5064,5065, 5069,5070,5085	J02245154	" " " " 150kΩ
***** VCO UNIT *****					
Symbol No.	Part No.	Description			
		IC			
Q5001	G1090118	NJM78L09A			
Q5025	G1090395	SN74LS145N			
		FET			
Q5003,5004,5007, 5008,5011,5012, 5015,5016,5019, 5020	G3090036	2SK19TM-BL			
		BLOCK RESISTOR			
		RB5001	J40900034	EXB-P810-472 4.7Kx10	
Q5022,5023	G4800730G	3SK73GR			
		THERMISTOR			
		TH5001	G9090002	D22A	
Q5002,5005,5006, 5009,5010,5013, 5014,5017,5018, 5021	G3107331P	2SA733AP			
		TRANSISTOR			
Q5024	G3318150G	2SC1815GR			
		DIODE			
D5002,5003,5006, 5007,5010,5011, 5014,5015,5018, 5019	G2090027	Si	ISS53		
D5001,5004,5005, 5008,5009,5012, 5013,5016,5017, 5020	G2090161	Varactor	1SV55		
		RESISTOR			
R5006,5054,5076, 5082,5088	J02245101	Carbon film	1/4W SJ	100Ω	
R5012,5023,5026, 5034,5040,5048, 5062,5068,5075	J01245101	" "	" TJ	100Ω	
R5089	J02245151	" "	" SJ	150Ω	
R5081	J01245181	" "	" TJ	180Ω	
R5090,5091	J01215221	" "	1/8W TJ	220Ω	
R5087	J02245221	" "	1/4W SJ	220Ω	
R5074	J02245681	" "	" "	680Ω	
R5005,5015,5019, 5029,5033,5043, 5047,5057,5061, 5071	J02245102	" "	" "	1kΩ	
R5002	J02245472	" "	" "	4.7kΩ	
R5001,5003,5004, 5010,5011,5017, 5018,5024,5025	J02245103	" "	" "	10kΩ	
				C5092	K02172050 Ceramic 50WV CH 5pF (DD104CH050C50V02)
				C5047,5063,5072, 5073	K06173080 " " UJ 8pF (DD104UJ080D50V02)
				C5014,5015,5024, 5025,5031,5041, 5057	K06173100 " " " 10pF (DD104UJ100D50V02)
				C5023,5030,5040, 5046,5056,5062, 5079	K06175120 " " " 12pF (DD104UJ120J50V02)
				C5016,5078	K06175150 " " " 15pF (DD104UJ150J50V02)
				C5006,5008,5032, 5039,5048	K06175180 " " " 18pF (DD104UJ180J50V02)
				C5007,5055	K05175220 " " RH 22pF (DD104RH220J50V02)
				C5009,5071,5081	K06175220 " " UJ 22pF (DD104UJ220J50V02)
				C5099	K02179009 " " CH 22pF (DD104CH220J50V02)
				C5054,5064,5070	K06175270 " " UJ 27pF (DD104UJ270J50V02)
				C5093	K02175270 " " CH 27pF (DD105CH270J50V02)
				C5080	K05175330 " " RH 33pF (DD105RH330J50V02)
				C5017,5022,5033, 5038,5049,5065	K06175330 " " UJ 33pF (DD104UJ330J50V02)
				C5106	K02179015 " " CH 43pF (DD106CH430J50V02)
				C5102,5104,5107	K02175470 " " " 47pF (DD106CH470J50V02)
				C5100	K02175560 " " " 56pF (DD106CH560J50V02)

PLAN TABLE FOR BOARD V100

10kΩ
22kΩ
56kΩ
100kΩ
150kΩ
180kΩ
330kΩ
470kΩ
k10
CH 5pF
J 8pF
10pF
12pF
15pF
18pF
RH 22pF
UI 22pF
CH 22pF
UI 27pF
CH 27pF
RH 33pF
UI 33pF
CH 43pF
47pF
56pF

C5105	K02179017	Ceramic 50WV CH 62pF (DD106CH620J50V02)		Q9000042	0.6-12.5
C5086,5088,5103	K02175820	" " " 82pF (DD107CH820J50V02)			
C5098	K30176121	Dipped Mica " 120pF (Z12C121K05)	CPU UNIT		
C5101	K30176181	" " " 180pF (Z17D181K05)	Symbol No.	Part No.	Description
				C023730A	PCB with Components
C5018,5021,5034, 5037,5050,5053, 5066,5069,5082, 5089, 5108-5113	K12171102	Ceramic " E 0.001μF (DD104E102P50V02)			
			*** CPU BOARD ***		
C5003,5005,5010, 5013,5019,5020, 5026,5029,5035, 5036,5042,5045, 5051,5052,5058, 5061,5067,5068, 5074,5077,5083, 5085,5087,5091, 5094,5095,5097	K13179008	" " F 0.01μF (DD106F103Z50V02)	PB-2373	F0002373 C023730A	Printed Circuit Board PCB with components (with Connector Unit A, B)
					IC
			Q6009	G1090124	MC14016B
			Q6003	G1090290	MC14093B
C5004	K13179009	" " F 0.047μF (DD110F473Z50V02)	Q6028,6029	G1090312	MC14504B
			Q6005	G1090397	MSM80C85ARS
C5084	K50177222	Mylar " 0.0022μF (50F2U222M)	Q6040	G1090092	SN74LS00N
			Q6008, 6013-6015,6038	G1090180	SN74LS02N
C5002	K50177104	" " 0.1μF (50F2U104M)	Q6004	G1090418	SN74LS14N
C5011,5012,5027, 5028,5043,5044, 5059,5060,5075, 5076	K40129008	Electrolytic 16WV 33μF (16RE33)	Q6012	G1090401	SN74LS42N
			Q6010	G1090196	SN74LS74N
			Q6006	G1090398	SN74LS75N
			Q6033	G1090100	SN74LS123N
C5090,5096	K40129004	" " 10μF (16RE10)	Q6025	G1090395	SN74LS145N
			Q6007	G1090399	SN74LS190N
C5001	K40129018	" " 0.33μF (AL16WV0.33MFM)	Q6019,6020	G1090404	SN74LS365N
			Q6011,6021-6023	G1090400	SN74LS373N
			Q6032	G1090084	μPC78L05
			Q6017,6018	G1090403	μPD4451C-1
		TRANSFORMER	Q6016	G1090518	μPD2364C-010
T5001-5003	L0021235		Q6026,6027	G1090406	μPD8255AC-5
T5004	L0021236		Q6024	G1090405	μPD8279C-5
T5005-5007	L0021237		Q6034		TBP18SA030N- ROM
T5008-5010	L0021238				
					TRANSISTOR
		INDUCTOR	Q6002,6030	G3107331	2SA733AP
L5007	L0021243	0.103μH	Q6001	G3318150	2SC1815Y
L5004,5005	L0021240	0.136μH			
L5010	L0021239	0.178μH			
L5009	L0021242	0.276μH			IC SOCKET
L5008	L0021241	0.622μH		P3090062	C841602 16P
L5002,5003	L1190005	FL4H1ROM 1μH		P3090065	C842402 24P
L5001	L1190038	FL5H271K 270μH		P3090067	C844002 40P
		RECEPTACLE			DIODE
J5001	P0090220	5045-04A	D6002,6006-6012	G2015550	Si 1S1555
J5002	P1090255	TMP-JA	D6001	G2090001	" 10D1
J5003	P0090183	RT-01T-1.0B	D6003	G2090008	Zener WZ071
			D6004,6005	G2090244	Schottky 1SS106
TP5001	Q5000050	TP-K			
					CRYSTAL
			X6001	H0102460	HC-18/U 6MHz
		JUMPER			
	Q9000043	0.6-5.0			
	Q9000049	0.6-7.5			
	Q9000002	0.6-10.0			

		RESISTOR					INDUCTOR	
R6034	J20306059	Metallic film	1W	0.5Ω	L6001	L2030067B		
R6036	J00275470	Carbon film	1/2W	47Ω	L6002-6006	L1190133	LAL04NA101K	
R6045	J01245101	" "	1/4W TJ	100Ω	L6007	L1190020	FL5H-151K	150μH
R6038-6044	J01215221	" "	1/8W	220Ω				
R6001,6003,6004	J02245331	" "	1/4W SJ	330Ω		T9204534		
R6029	J02245561	" "	" "	560Ω		T9204535		
R6021,6033,6035	J02245102	" "	" "	1kΩ		T9204536		
R6022	J02245222	" "	" "	2.2kΩ				
R6015-6017	J02245332	" "	" "	3.3kΩ				
R6023	J02245392	" "	" "	3.9kΩ		R0080050C	Shield Case (CPU)	
R6005,6018-6020	J02245472	" "	" "	4.7kΩ		R0080250	" " Cover	
R6024	J02245822	" "	" "	8.2kΩ		R0080030A	" " "	
R6006,6007,6009, 6011,6013,6014, 6030-6032	J02245103	" "	" "	10kΩ				
*** CONNECTOR UNIT A ***								
R6025	J02245153	" "	" "	15kΩ	PB-2467	F0002467	Printed Circuit Board	
R6026	J02245333	" "	" "	33kΩ		C024670		
R6027	J02245683	" "	" "	68kΩ				
R6037	J02245104	" "	" "	100kΩ				
R6028	J02245124	" "	" "	120kΩ				
R6010,6012	J02245474	" "	" "	470kΩ				
BLOCK RESISTOR								
RB6005	J40900036	EXB-P85-103	10Kx5					
RB6001-6004	J40900035	EXB-P88-103	10Kx8					
CAPACITOR								
C6003,6004	K02175101	Ceramic	50WV CH	100pF (DD107CH101J50V02)	J4605,4607,4612	P0090328	IMSA-1068-04L-27.4Ω	4P
C6001, 6005-6015, 6032,6042,6044, 6063,6077,6078, 6094,6095,6098, 6107,6108,6116, 6117,6179,6180	K14180103	"	63WV	0.01μF (RD871-1FZ103Z)	J4608 J4601,4603 J4613 J4611 J4602,4606,4609 J4604 J4610	P0090329 P0090330 P0090318 P0090331 P0090332 P0090333 P0090337	IMSA-1068-05L-27.4Ω IMSA-1068-06L-27.5Ω IMSA-1068-06L IMSA-1068-07L-27.5Ω IMSA-1068-08L-27.5Ω IMSA-1068-09L-27.5Ω IMSA-1068-13L-27.5Ω	5P 6P 6P 7P 8P 9P 13P
C6118	K13179009	"	50WV	0.047μF (DD110F473Z50V)				
C6091,6093	K50177104	Mylar	"	0.1μF (50F2U10411)				
C6097	K40109014	Electrolytic	10WV	2200μF (10RC2200)				
C6115	K40179009	"	50WV	2.2μF (50RE2R2)				
C6092	K40149008	"	25WV	10μF (25RE10)	C4701,4702, 4712-4740	K12171222	Ceramic 50WV E	0.0022μF (DD105E222P50V)
C6043	K40129004	"	16WV	10μF (16RE10)	C4703-4709, 4711	K14180103	" " FZ	0.01μF (RD871-1FZ103Z)
C6002,6041,6109, 6114	K70120002	Tantalum	"	10μF (489D106X0016C1)				
CONNECTOR								
J6001,6004,6002, 6012,6014,6016	P0090292	IMSA-1068-04I-19L			L4701-4703	L1020672		
J6003,6008,6010, 6021	P0090296	IMSA-1068-04I-19L						
J6005	P0090297	IMSA-1068-04I-19L			J4706	P0090338	IMSA-1068-02L-34.6Ω	2P
J6011	P0090293	IMSA-1068-05I-19L			J4712	P0090302	IMSA-1068-02I-26Ω	2P
J6013	P0090301	IMSA-13I-19L			J4704,4708	P0090314	IMSA-1068-02L	2P
J6015	P0090295	IMSA-1068-07I-19L			J4701,4702	P0090315	IMSA-1068-03L	3P
J6016	P0090292	IMSA-1068-04I-19L			J4703	P0090316	IMSA-1068-04L	4P
J6017	P0090293	IMSA-1068-05I-19L			J4704	P0090340	IMSA-1068-04L-34.6Ω	4P
J6020,6022 (P6001)	P0090290	IMSA-1068-02I-19L			J4711	P0090304	IMSA-1068-04I-26Ω	4P
					J4710	P0090341	IMSA-1068-05L-34.6Ω	5P
					J4705	P0090318	IMSA-1068-06L	6P
					J4707	P0090345	IMSA-1068-09L-34.6Ω	9P

MIL-STD-883C METHOD 2000

150μH
0.0022μF
FZ 0.01μF
4P
5P
6P
6P
7P
8P
9P
13P
0.0022μF
FZ 0.01μF
2P
2P
2P
3P
4P
4P
4P
5P
6P
9P

MEMORY CHECK DECODER UNIT			Q7026	G3408800Y	2SD880Y
Symbol No.	Part No.	Description	Q7002,7022	G3090005	MPS-A13
PB-2465	F0002465	Printed Circuit Board			
	C024650A	PCB with Components			
					FET
			Q7016,7023	G3090035	2SK19TM-GR
		IC			
Q3801,3802	G1090506	SN74LS05N			
Q3803	G1090196	SN74LS74N			DIODE
Q3805	G1090403	μPD445LC-1	D7001	G2022090	Varactor 1S2209
			D7002	G2090161	" 1SV55
			D7003	G2090011	Zener WZ100
		TRANSISTOR			
Q3804	G3318150Y	2SC1815Y			
					CRYSTAL
			X7001	H0102457	HC-18/U 30MHz
		DIODE			
D3801-3803	G2090118	Schottky barrier 1SS97			THERMISTOR
			TH7001	G9090008	31D26
		RESISTOR			
R3806	J01245101	Carbon film 1/4W TJ 100Ω			
R3801,3802,3805	J01245332	" " " " 3.3kΩ			POSISTOR
R3803,3804	J01245103	" " " " 10kΩ	TH7002	G9090019	PTH507A01BG330N020
		CAPACITOR			RESISTOR
C3801	K13179008	Ceramic 50WV 0.01μF (DD106F103Z50V02)	R7055	J02245560	Carbon film 1/4W SJ 56Ω
			R7005,7007,7010,7013,7015,7020,7021,7025,7029,7034,7038,7039,7042,7045,7047,7060,7062,7064,7069,7075,7077,7080,7081,7083,7084,7088,7090,7091,7096	J02245101	" " " " 100Ω
		CONNECTOR			
J3801	P0090183	RT-01T-0.1B			
J3802	P0090356	5234-04A			
J3803,3804	P0090099	3022-10A			
			R7003	J02245151	" " " " 150Ω
			R7012,7017,7023,7024,7037,7041,7049,7063,7066,7068,7072,7087	J02245331	" " " " 330Ω
			R7014,7026,7043,7052,7067,7093,7094,7099,7100	J02245561	" " " " 560Ω
			R7050	J02245821	" " " " 820Ω
			R7001,7004,7016,7027,7030,7048,7054,7058,7076	J02245102	" " " " 1kΩ
		IC			
Q7009,7025	G1090296	HD10551P			
Q7013	G1090034	SN74LS90N	R7033	J02245222	" " " " 2.2kΩ
Q7005,7010,7014,7017	G1090062	SN76514N	R7095	J02245332	" " " " 3.3kΩ
			R7058	J02245472	" " " " 4.7kΩ
Q7001,7020	G1090048	TC5081AP	R7002,7009,7019,7032,7036,7046,7051,7057,7071,7074,7079,7086,7092,7098	J02245103	" " " " 10kΩ
Q7007,7019	G1090247	TC9122P			
Q7028	G1090299	μPC7805H			
Q7027	G1090294	μPC7808H			
			R7008,7018,7035,7044,7070,7073	J02245333	" " " " 33kΩ
		TRANSISTOR			
Q7036	G3107331P	2SA733AP	R7097	J02245473	" " " " 47kΩ
			R7078,7085	J02245563	" " " " 56kΩ
Q7003,7004,7006,7008,7015,7018,7024,7031-7033,7035	G3305350A	2SC535A	R7006,7011,7022,7028,7031,7040,7059,7061,7065,7082,7089	J02245104	" " " " 100kΩ
Q7011,7012,7021,7029,7030,7034	G3318150Y	2SC1815Y			

			DISPLAY UNIT (A)		
			Symbol No.	Part No.	Description
	Q500011	Wrapping terminal C	PB-2364B	F0002364B C023640A	Printed Circuit Board PCB with Components
	R0079790	Shield Case			
	R0079800	" " Cover			FCD
	R0079810	" Plate	V1401 V1402	G6090028 G6090029	FIP-9E8A FIP-9P5
					LED
			D1401-1406	G2090134	TLY205
DIAL UNIT					
Symbol No.	Part No.	Description			
PB-2386A	F0002386A C023860A	Printed Circuit Board PCB with Components			RESISTOR
			R1407 R1408	J01245339 J01245100 J01245680	Carbon film 1/4WV TJ 3.3Ω " " " " 10Ω " " " " 68Ω
		IC	R1401-1406	J01245331	" " " " 330Ω
Q1303	G1090027	MC14001B			
Q1305	G1090068	MC14011B			
Q1302	G1090176	MC14012B			CONNECTOR
Q1306	G1090067	MC14013B	J1401,1402,1404	P0090092	3022-08A 8pF
Q1308	G1090124	MC14016B	J1403	P0090090	3022-09A 9pF
Q1301	G1090290	MC14093B			
Q1304	G1090224	MC14584B			
Q1307	G1090092	SN74LS00N			
		DIODE			
D1301-1310	G2015550	Si 1S1555			
			DISPLAY UNIT (B)		
			Symbol No.	Part No.	Description
			PB-2368A	F0002368A C023680A	Printed Circuit Board PCB with Components
		RESISTOR			
R1304	J02245471	Carbon film 1/4W SJ 470Ω			
R1305	J02245222	" " " " 2.2kΩ			IC
R1312	J02245472	" " " " 4.7kΩ	Q1606	G1090409	MC14514B
R1303,1306,1308	J02245103	" " " " 10kΩ	Q1602-1604	G1090260	MSL912RS
R1314	J02245153	" " " " 15kΩ	Q1607	G1090084	NJM78L05A
R1301,1302	J01245104	" " " TJ 100kΩ	Q1605	G1090004	SN7445N
R1309-1311	J02245104	" " " SJ 100kΩ	Q1601	G1090408	TCS067BP
R1313	J02245225	" " " " 2.2MΩ			
		BLOCK RESISTOR			
RB1301	J40900037	EXB-P84-563 56Kx4	Q1609 Q1608	G3318150G G3320020L	2SC1815GR 2SC2002L
		CAPACITOR			
C1301-1305,1307	K50177102	Mylar 50WV 0.001μF (50F2U102M)	D1601-1604, 1613-1624,1633	G2015540	Si 1S1554
C1309	K50177103	" " " 0.01μF (50F2U103M)	D1634	G2090033	Ge 1N270
C1308	K40149008	Electrolytic 25WV 10μF (25RE10)			
C1307	K50177682	" " " 0.0068μF (50F2U682M)	R1614 R1621 R1613 R1617	J02245270 J02245472 J02245562 J02245103	RESISTOR Carbon film 1/4W SJ 27Ω " " " " 4.7kΩ " " " " 5.6kΩ " " " " 10kΩ
J1302	P0090219	5045-03A	R1607,1608 R1608	J02245333 J02245683	" " " " 33kΩ " " " " 68kΩ
J1301	P0090220	5045-04A			
J1303	P0090222	5045-06A	R1601-1606, 1609-1612, 1615,1616	J02245104	" " " " 100kΩ

D1803-1825,1834, 1836-1841	G2090027	Si	1SS53	REG UNIT		
				Symbol No.	Part No.	Description
D1833	G2090185	Zener	HZ5C-2	PB-2366B	F0002366B	Printed Circuit Board
D1801	G2090201	"	RD3.3EB-3		C023660A	PCB with Components
		CRYSTAL				
X1801	H0102458	HC-18/U	6.8MHz			IC
				Q1901	G1090037	MC14572UB
		RESISTOR				
R1803,1805,1820, 1821	J02245221	Carbon film	1/4W SJ 220Ω			TRANSISTOR
R1823	J02245331	"	" " " " 330Ω	Q1917,1918	G3104960Y	2SA496Y
R1804,1824	J02245561	"	" " " " 560Ω	Q1904,1905,1913, 1919,1920	G3107331Q	2SA733AQ
	J01245102	"	" " " " TJ 1kΩ			
R1801,1807,1811, 1817,1818	J02245102	"	" " " " SJ 1kΩ	Q1903,1914,1915	G3109500Y	2SA950Y
				Q1906-1908	G3309451Q	2SC945AQ
R1822	J02245152	"	" " " " 1.5kΩ	Q1902	G3318150G	2SC1815GR
R1806	J02245182	"	" " " " 1.8kΩ	Q1910-1912	G3318150Y	2SC1815Y
R1815,1816,1829	J02245222	"	" " " " 2.2kΩ	Q1909	G3320020L	2SC2002L
R1828	J02245472	"	" " " " 4.7kΩ			
R1831	J02245562	"	" " " " 5.6kΩ			
	J02245682	"	" " " " SJ 6.8kΩ			DIODE
R1833	J02245822	"	" " " " 8.2kΩ	D1914,1916,1919, 1920	G2090093	Ge 1N270
R1810,1812,1825, 1830,1832	J02245103	"	" " " " 10kΩ	D1907	G2015880	Si 1S1588
	J01245103	"	" " " " TJ 10kΩ	D1901-1904, 1910,1918,1921	G2090027	" 1SS53
R1808,1809	J02245153	"	" " " " SJ 15kΩ			
R1826	J02245223	"	" " " " 22kΩ	D1911	G2090217	Zener HZ3C-1
R1813,1814	J02245333	"	" " " " 33kΩ	D1915	G2090238	" HZ3C-3
				D1906	G2090139	" WZ051
				D1908	G2090182	" HZ7A-2
				D1909	G2090251	" HZ11C-1
		POTENTIOMETER				
VR1801	J51745102	H0651A007-1KB	1kΩB			
		CAPACITOR				
C1802,1806	K02175330	Ceramic	50WV CH 33pF (DD105CH330J50V)	R1921	J20336050	Metallic film 2W 5Ω
				R1922	J02245181	Carbon film 1/4W SJ 180Ω
C1808	K12171102	"	" " 0.001μF (DD104E102P50V)	R1911,1920	J02245331	" " " " 330Ω
				R1912	J02245471	" " " " 470Ω
C1801,1804	K13179009	"	" " 0.047μF (DD110F473Z50V)	R1913	J02245561	" " " " 560Ω
				R1901	J02245681	" " " " 680Ω
C1811	K19149013	"	25WV 0.01μF (UAT05X103K-L05AE)	R1916,1924,1947	J02245102	" " " " 1kΩ
				R1917,1941	J02245122	" " " " 1.2kΩ
C1810	K19149023	"	" " 0.068μF (UAT10X683K-L45AE)	R1940	J02245182	" " " " 1.8kΩ
				R1928,1930	J02245222	" " " " 2.2kΩ
C1807	K40109011	Electrolytic	10WV 33μF (10RE33)	R1915	J02245272	" " " " 2.7kΩ
				R1914,1935	J02245332	" " " " 3.3kΩ
C1803	K40109002	"	" " 47μF (10RE47)	R1936	J02245472	" " " " 4.7kΩ
				R1910,1943,1948	J02245562	" " " " 5.6kΩ
C1805	K40129018	"	" " 0.33μF (AL16WV0.33MFM)	R1906	J01245682	" " " " TJ 6.8kΩ
				R1919	J02245682	" " " " SJ 6.8kΩ
C1809	K70120002	Tantalum	16WV 10μF (489D106X0016C1)	R1905, 1907-1909, 1925,1926,1931, 1934,1937,1939, 1942,1946	J02245103	" " " " 10kΩ
				R1933	J02245183	" " " " 18kΩ
				R1908	J02245223	" " " " 22kΩ
		INDUCTOR				
L1801	L1190038	FL5H-271K	270μH	R1927,1932	J02245273	" " " " 27kΩ
				R1938,1944	J02245563	" " " " 56kΩ
				R1945	J02245104	" " " " 100kΩ
				R1918	J02245394	" " " " 390kΩ
		CONNECTOR				
J1804	P0090218	5045-02A		R1903	J02245474	" " " " 470kΩ
J1806,1807	P0090219	5045-03A				
J1801,1803	P0090220	5045-04A				
J1802,1808	P0090183	RT-01T-1.0B				

		CAPACITOR					DIODE	
C1914,1915	K12171102	Ceramic	50WV	0.001 μ F	D2301	G2090027	Si	1SS53
		(DD104E102P50V)						
C1908	K50177103	Mylar	50WV	0.01 μ F				
		(50F2U103M)						SWITCH
C1913	K50177153	"	"	0.015 μ F	S2301	N4090060	SUT02A/E36674920	
		(50F2U153M)						
C1901	K50177273	"	"	0.027 μ F				
		(50F2U273M)						RESISTOR
C1905,1906	K50177333	"	"	0.033 μ F	R2302	J02245222	Carbon film 1/4WV SJ 2.2k Ω	
		(50F2U333M)			R2303,2304	J02245103	" " " " 10k Ω	
C1912	K50177104	"	"	0.1 μ F				
		(50F2U104M)						
C1909	K70120003	Tantalum	16WV	47 μ F				
		(489D476X0016F1)						
C1911	K40149008	Electrolytic	25WV	10 μ F				
		(25RE10)						
					SWITCH UNIT B			
C1902	K40129008	"	16WV	33 μ F	Symbol No.	Part No.	Description	
		(16RE33)			PB-2378A	F0002378A	Printed Circuit Board	
C1910	K40129002	"	"	47 μ F		C023780A	PCB with Components	
		(16RE47)						
C1904,1907	K40149003	"	25WV	100 μ F				
		(25RE100)						SWITCH
					S2401	N4090061	SUT21A1E36674680	
					POTENTIOMETER			
VR1901	J51752501	RGS6-FAN	500 Ω					
VR1902	J51752502	RGS6-FAN	5k Ω					
					UP/DOWN SWITCH UNIT			
		INDUCTOR			Symbol No.	Part No.	Description	
L1902	L1190017	FL5H-102K	1mH	PB-2379A	F0002379A	Printed Circuit Board		
L1901	L2030068				C023790A	PCB with Components		
					TRANSFORMER			
T1901	L3030094	MC-102C		S2501-2503	N4090065	E31198940/KHC10902		
					RELAY			
RL1901,1902	M1190048	URK-3						
					CONNECTOR			
J1902,1904	P0090218	5045-02A		Symbol No.	Part No.	Description		
J1903,1910,1911	P0090219	5045-03A		PB-2377	F0002377	Printed Circuit Board		
J1905,1912	P0090220	5045-04A			C023770A	PCB with Components		
J1906	P0090221	5045-05A						
J1901	P0090223	5045-07A						
J1907-1909	P0090183	RT-01T-1.0B					PHOTO SENSOR	
				PS2601,2602	G0090003	EE-SH3-X-1		
	Q5000049	TP-J						
							RESISTOR	
				R2604	J01245221	Carbon film 1/4W TJ 220 Ω		
					SWITCH UNIT A			
Symbol No.	Part No.	Description						
PB-2369B	F0002369B	Printed Circuit Board			VR2601,2602	J50754103	POTENTIOMETER	
	C023690A	PCB with Components					H0612A 10KB 10k Ω B	
					PLUG			
		TRANSISTOR			P2601 (with wire)	T9204443	S250-04	
Q2301	G3318150G	2SC1815GR						

PROTECTOR UNIT			TRANSISTOR		
Symbol No.	Part No.	Description	Q3502	G3318150Y	2SC1815Y
PB-2419A	F0002419A	Printed Circuit Board	Q3503	G3405920Q	2SD592Q
	C024190A	PCB with Components			
					DIODE
Q2901	G1090248	IC AN6551	D3501 3503	G2015550	Si 1S1555
					RESISTOR
D2901-2903	G2015550	DIODE	R3509,3512	J01245102	Carbon film 1/4W TJ 1k Ω
		Si 1S1555	R3505,3511	J02245102	" " " SJ 1k Ω
			R3501	J02245152	" " " " 1.5k Ω
			R3510	J02245472	" " " " 4.7k Ω
		RESISTOR	R3502,3506	J02245433	" " " " 43k Ω
R2905	J02245152	Carbon film 1/4W SJ 1.5k Ω	R3503,3507	J02245473	" " " " 47k Ω
R2909	J01245152	" " " TJ 1.5k Ω	R3508	J02245563	" " " " 56k Ω
R2903,2908	J02245332	" " " SJ 3.3k Ω	R3504	J02245394	" " " " 390k Ω
R2911	J01245682	" " " TJ 6.8k Ω			
R2904,2907	J02245103	" " " SJ 10k Ω			
R2914	J02245183	" " " " 18k Ω			
R2913	J02245333	" " " " 33k Ω			CAPACITOR
R2906,2910	J02245104	" " " " 100k Ω	C3501-3504	K13179008	Ceramic 50WV 0.01 μ F (DD106F103Z50V02)
R2901	J32009003	Meter shunt 0.125 Ω ±5%	C3505,3506	K70120002	Tantalum 16WV 10 μ F (489D106X0016C1)
R2902	J32009004	" " 0.025 Ω ±5%			
R2915	J30376339	Cement 5W 3.3 Ω			
R2916	J20376181	Metallic film 5W 180 Ω			
					CONNECTOR
			J3501,3502	P0090218	5045-02A
		CAPACITOR	J3503	P0090219	5045-03A
C2903-2905	K13179009	Ceramic 50WV 0.047 μ F (DD110F473Z50V02)			
C2901,2902	K40129010	Electrolytic 16WV 2200 μ F (16RE2200)		Q5000011	Wrapping terminal C
C2906	K40129008	" " 33 μ F (16RE33)			
					MONITOR UNIT
			Symbol No.	Part No.	Description
VR2901	J51723473	POTENTIOMETER	PB-2477	F0002477	Printed Circuit Board
		H1051A017-47KB 47k Ω B		C024470A	PCB with Components
					INDUCTOR
CH2901	L2030069	1.7mH 2.5A	Q3601,3603-3605	G3801070C	FET 2SK107-3
					CONNECTOR
J2902	P0090226	5045-10A	Q3602	G3107331P	TRANSISTOR 2SA733AP
J2901	P1090289	5219-06A	Q3606	G3305090Y	2SC509Y
J2903	Q6000074	M11-22-7P			
					DIODE
			D3602	G2090027	Si 1SS53
			D3601,3603	G2090244	Schottky 1SS106
					CONTROL UNIT
Symbol No.	Part No.	Description			
PB-2432	F0002432	Printed Circuit Board	R3614	J20306100	Metallic film 1W 10 Ω
	C024320A	PCB with Components	R3613	J02245182	Carbon " 1/4W SJ 1.8k Ω
			R3604,3605,3612	J02245103	" " " " 10k Ω
			R3602,3611	J02245223	" " " " 22k Ω
		IC	R3603,3606-3610	J02245563	" " " " 56k Ω
Q3501	G1090248	AN6551	R3615	J02245683	" " " " 68k Ω
Q3504	G1090123	NJM78L08	R3601	J02245104	" " " " 100k Ω

		RESISTOR					CAPACITOR		
R301	J02245560	Carbon film	1/4W	56Ω	C8044	K30279026	Dipped Mica	500WV	82pF
R302	J02245821	" "	" "	820Ω			(DM15D820K5)		
R303,304	J02245332	" "	" "	3.3kΩ	C8033	K30279041	" "	"	390pF
							(DM15D391K5)		
					C8032,8034	K30279945	" "	"	560pF
							(DM15D561K5)		
		POTENTIOMETER							
VR301	J51723472	H1051A011	4.7KB	4.7kΩB	C8028	K30279092	" "	"	750pF
							(DM19D751J5)		
					C8027,8029	K30279097	" "	"	5000pF
							(DM19D502J5)		
		CAPACITOR							
C301,302	K40149003	Electrolytic	25WV	10μF	C8005,8006	K10179038	Ceramic	50WV B	0.0047μF
		(25RE100)					(DD108B472K50V)		
C303	K50177223	Mylar	50WV	0.022μF	C8002,8010,8011, 8016,8036	K10179024	" "	B	0.01μF
		(50F2U223M)					(CDS080XB103K50V)		
					C8040,8041	K10246103	"	250WV	0.01μF
							(CD125XB103K250V)		
					C8001,8003,8007, 8008,8012,8014, 8017,8019,8021, 8023,8026,8045	K13179009	"	50WV F	0.047μF
							(DD110F473Z50V02)		
100W P A UNIT									
Symbol No.	Part No.	Description							
PB-2013B	F0002013B	Printed Circuit Board			C8030,8031	K55239001	Polypropylene	150WV	0.047μF
	C020134A	PCB with Components					(PRA473K200V)		
					C8037	K19179001	"	50WV	0.1μF
							(RSB305YF104Z6L5)		
		IC							
Q8006	G1090294	μPC7808H			C8046,8047	K23140001	Chip	25WV	0.01μF
							(GR42Y5V103Z25V)		
					C8043	K19149007	Semiconductor Ceramic		0.0033μF
							(UAT05X332K-L05AE)		
		TRANSISTOR							
Q8001	G3315890	2SC1589			C8039	K50177104	Mylar	50WV	0.1μF
Q8002,8003	G3323950	2SC2395					(50F2U104M)		
Q8007	G3402880K	2SD288K			C8004,8009	K23170002	Ceramic Chip	"	0.1μF
Q8004,8005	G3090059	MRF422					(GR43Y5V104Z50V09)		
					C8022	K70120006	Tantalum	16WV	3.3μF
							(489D335X0016B1)		
					C8013,8015,8018, 8020,8024,8025, 8042	K70120002	"	"	10μF
							(489D106X0016C1)		
					C8038	K40169003	Electrolytic	35WV	330μF
							(35RE330)		
							POTENTIOMETER		
		THERMISTOR							
TH8001	G9090009	32D27			VR8001	J51727222	H1021A309	-2.2KB	
							TRANSFORMER		
		RESISTOR							
R8026	J02245010	Carbon film	1/4W SJ	1Ω	T8001	L0020289A			
R8009,8011	J00275159	" "	1/2W "	1.5Ω	T8002	L0020631C			
R8016,8018	J20306159	Metallic "	1W	1.5Ω	T8003	L0021284			
R8006	J00275479	Carbon "	1/2W	4.7Ω					
R8007	J00275180	" "	" "	18Ω	L8001-8004	L1020035A			INDUCTOR
R8019,8020	J20306180	Metallic "	1W	18Ω	L8005	L1020015			
R8012,8013	J00275240	" "	" "	24Ω	L8006	L1020395A			
R8002	J02245330	" "	1/4W "	33Ω	L8007	L1020015			
R8010	J01275390	" "	1/2W TJ	39Ω					
R8021,8022	J22355390	Metallic "	3W	39Ω		Q5000011	Wrapping terminal C		
		(ERG3SJ390 3W)							
R8023	J21335680	" "	2W	68Ω					
R8001	J02245121	Carbon "	1/4W SJ	120Ω					TERMINAL
R8014,8015	J01275121	" "	1/2W TJ	120Ω		Q5000006	STK-97		
R8024	J01245151	" "	1/4W SJ	150Ω					
R8003,8004	J00275331	" "	1/2W "	330Ω					
R8008	J02275102	" "	" "	1kΩ					INSULATOR
R8005	J01245152	" "	1/4W TJ	1.5kΩ		Q9000029	BUSH-66		

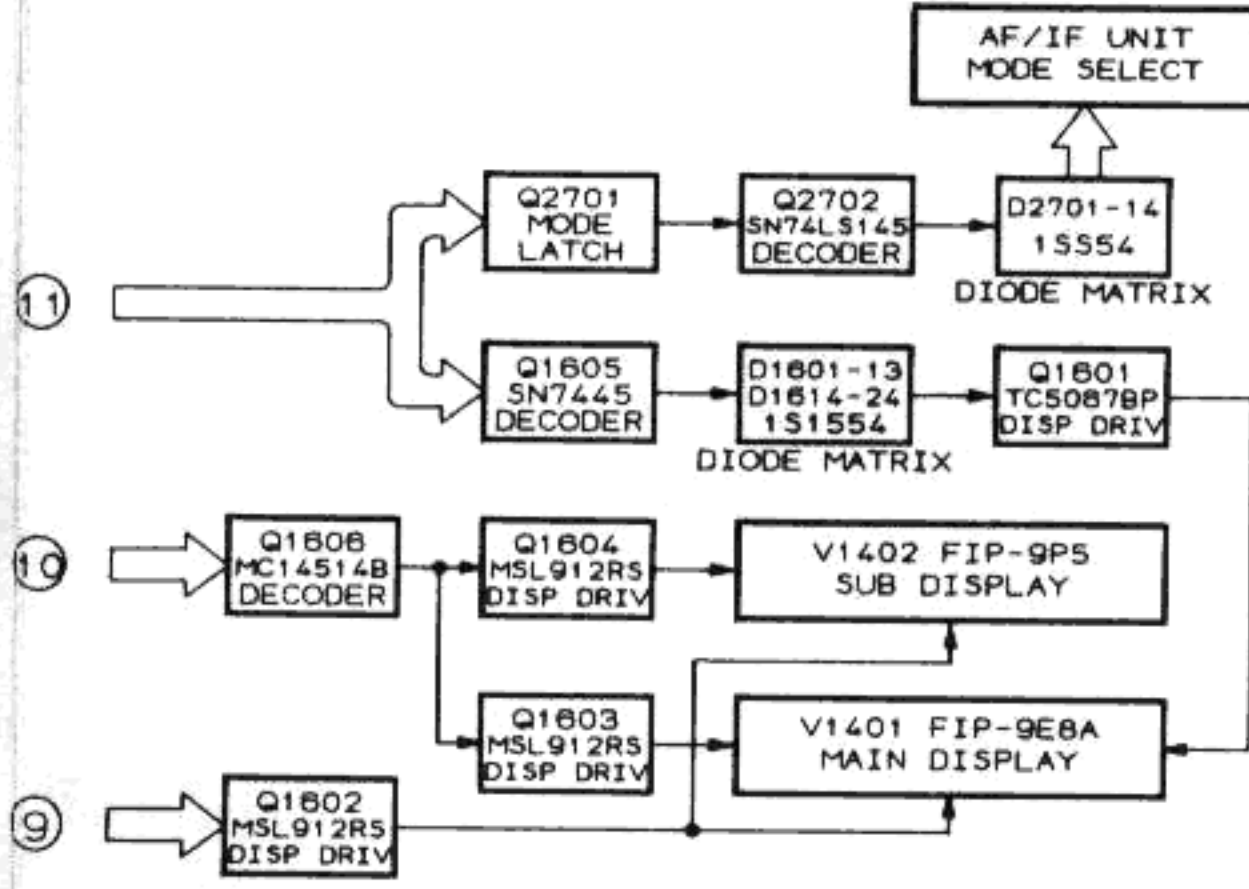
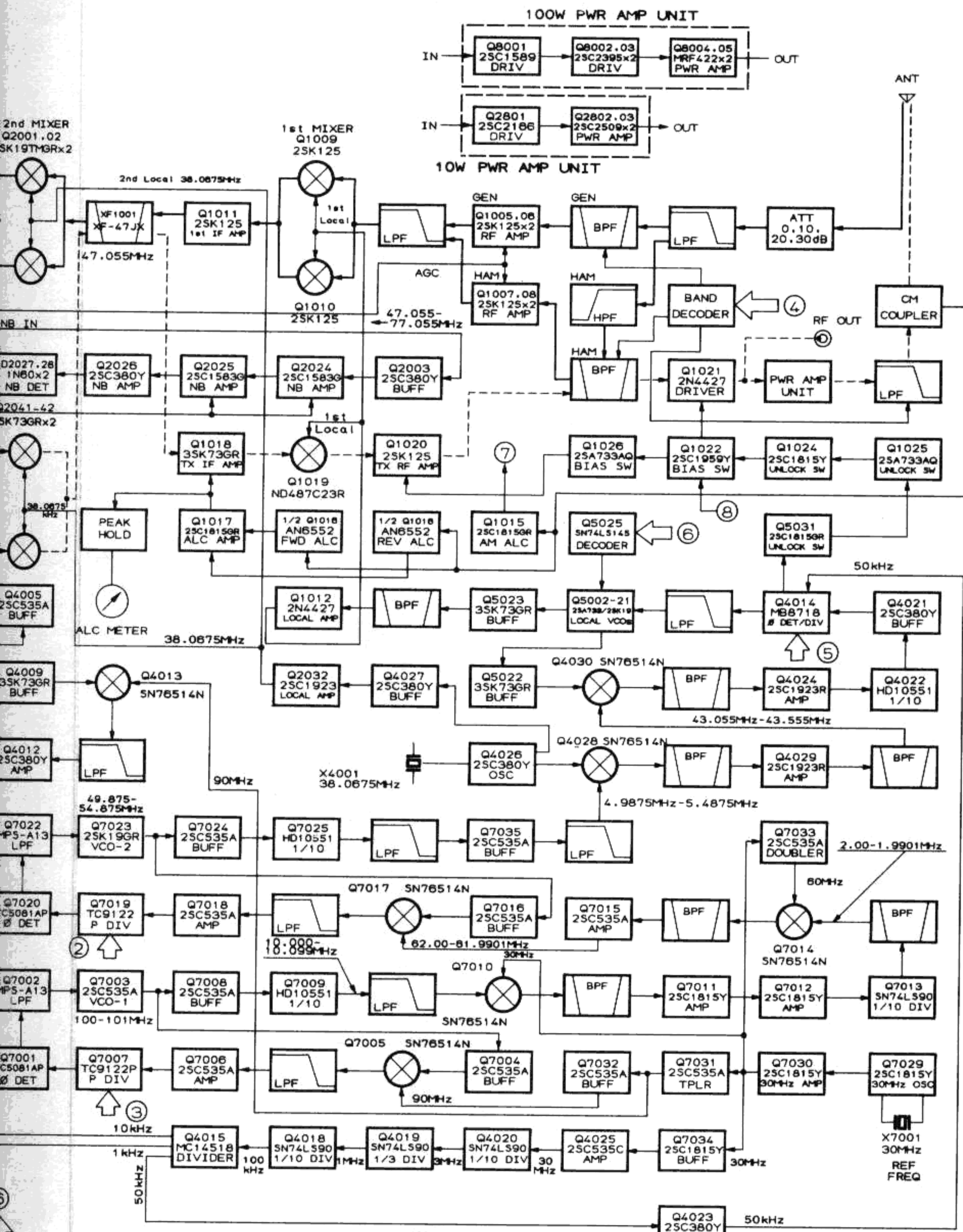

———> RECEIVE
 ———> CONTROL
 - - - -> TRANSMIT

FT-980
BLOCK DIAGRAM

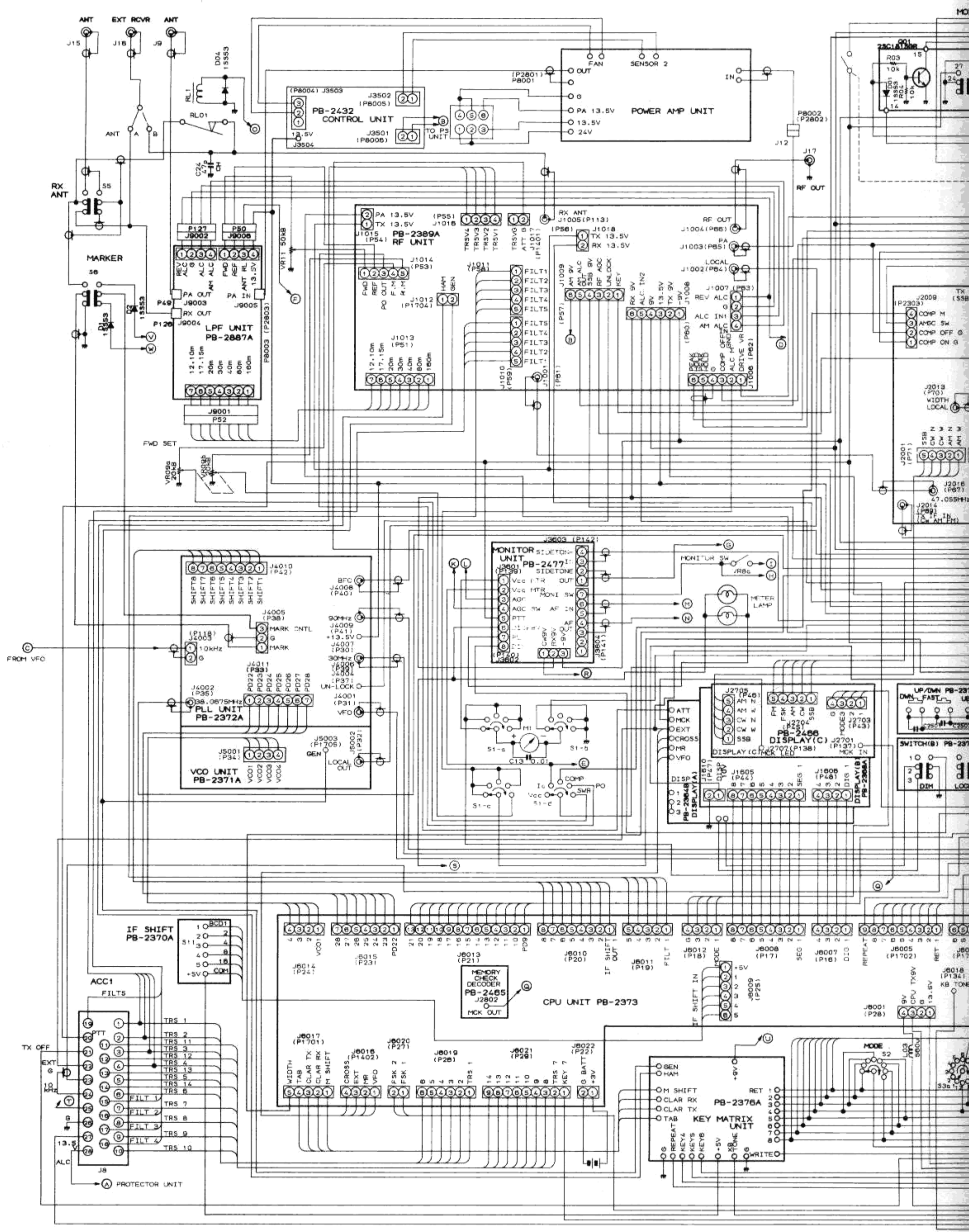

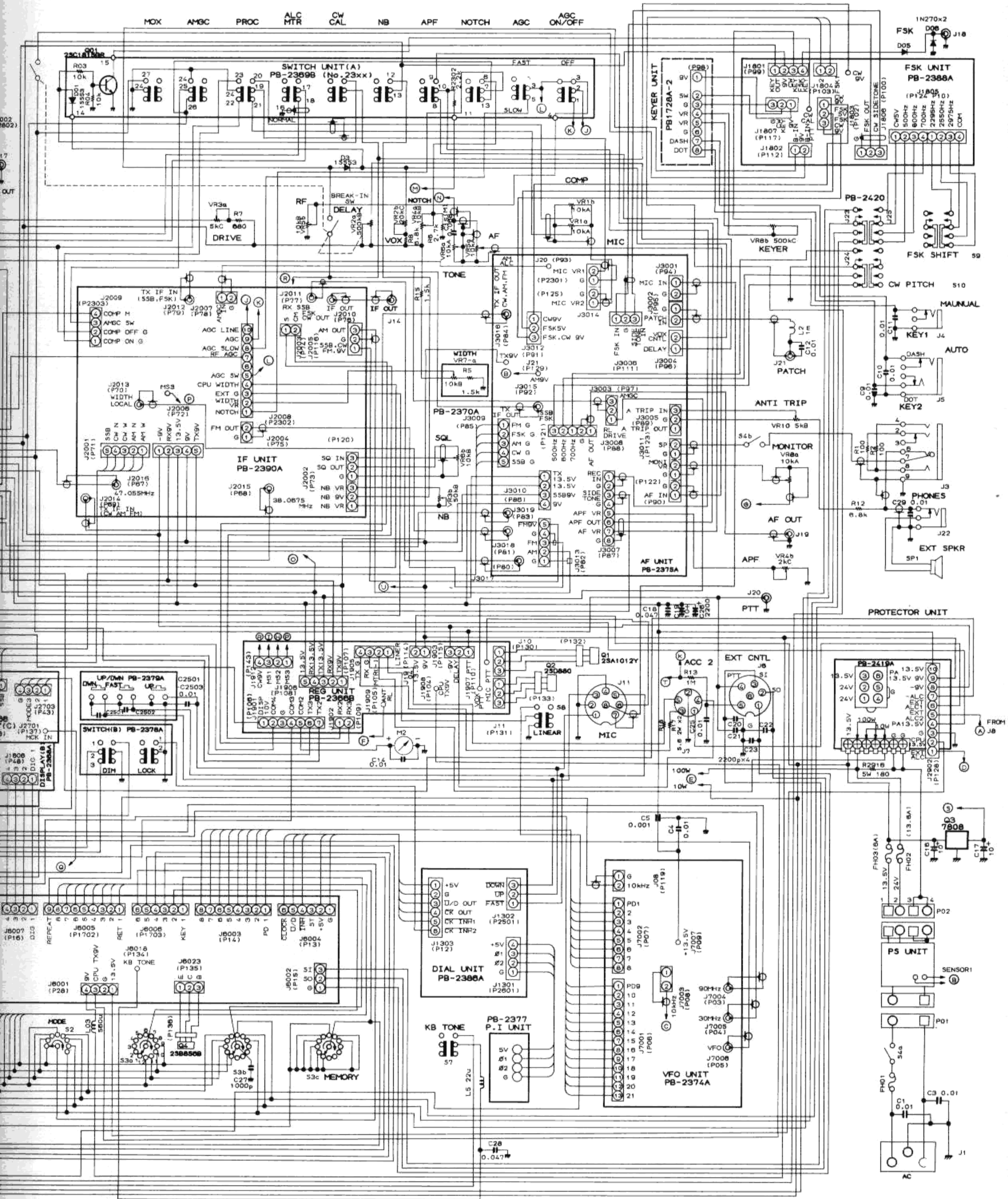

FT-980 CONNECTION DIAGRAM

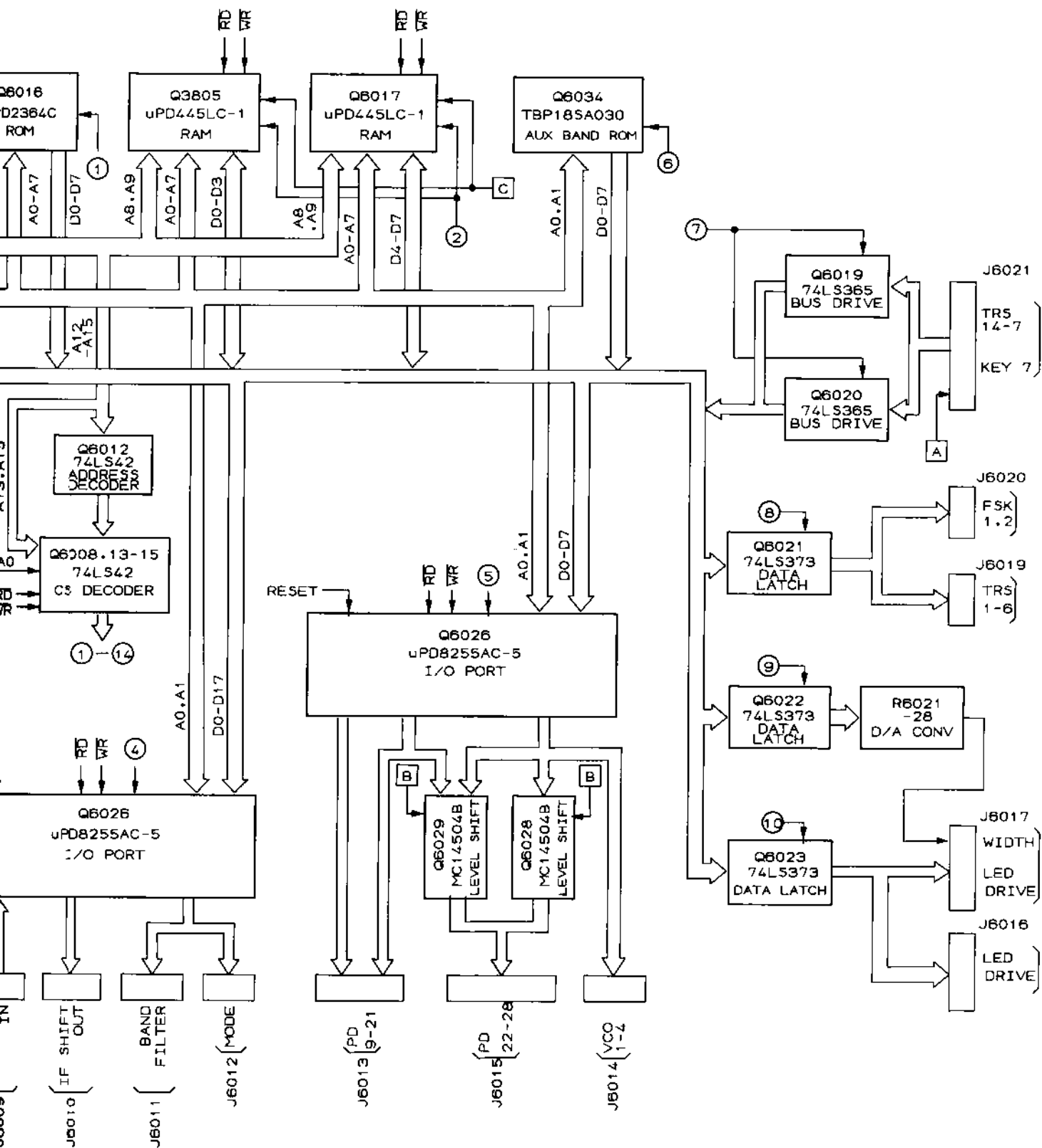

FT-980
CPU BOARD CIRCUIT DIAGRAM

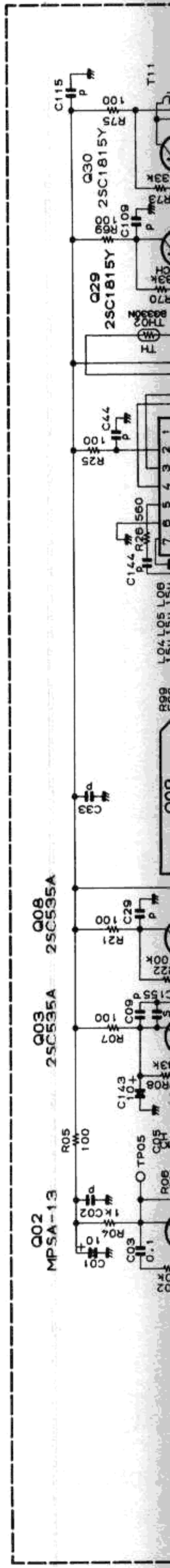
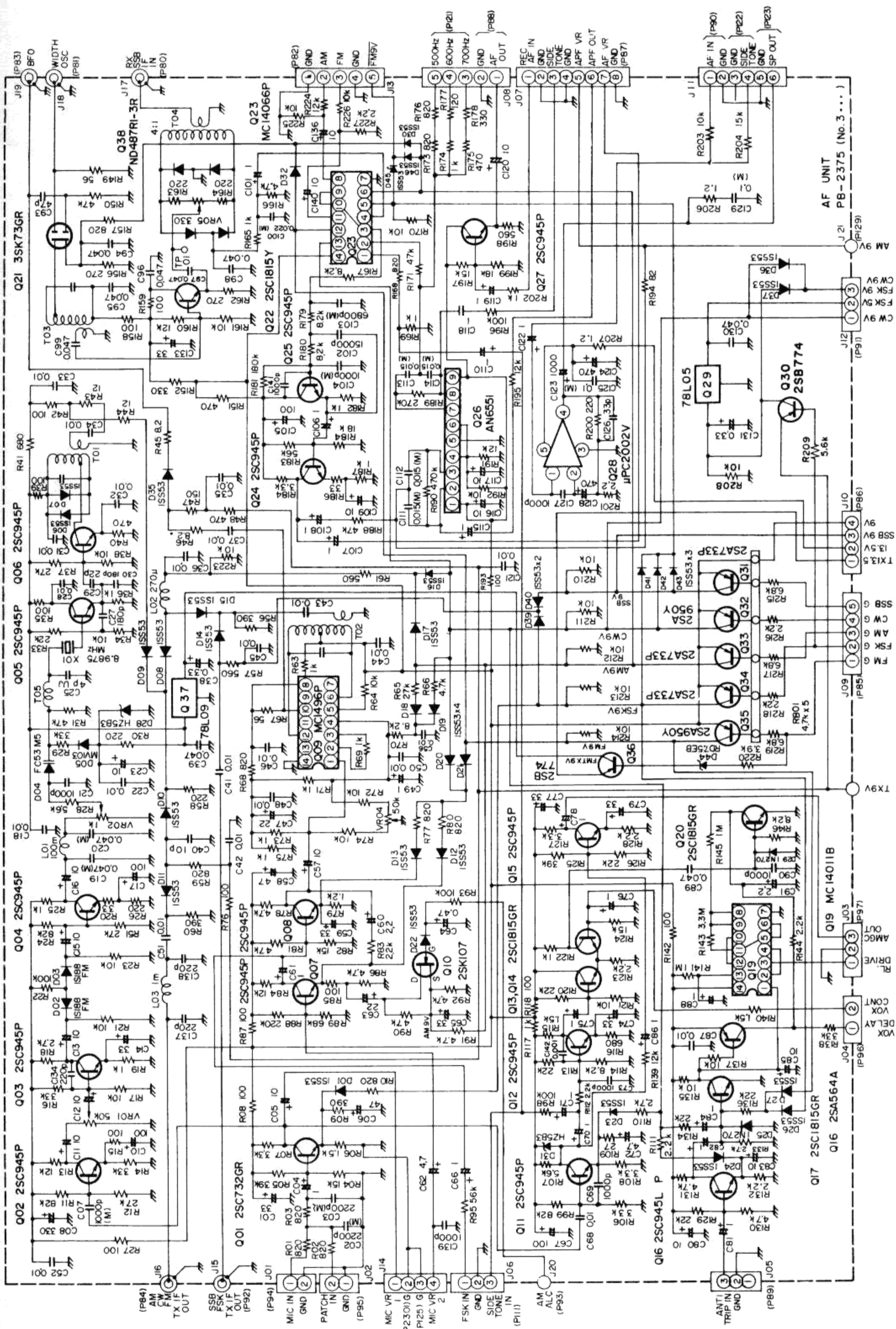

Q02 MPSA-13
Q03 2SC535A
Q08 2SC535A

Q09 2SC1815Y
Q10 2SC1815Y

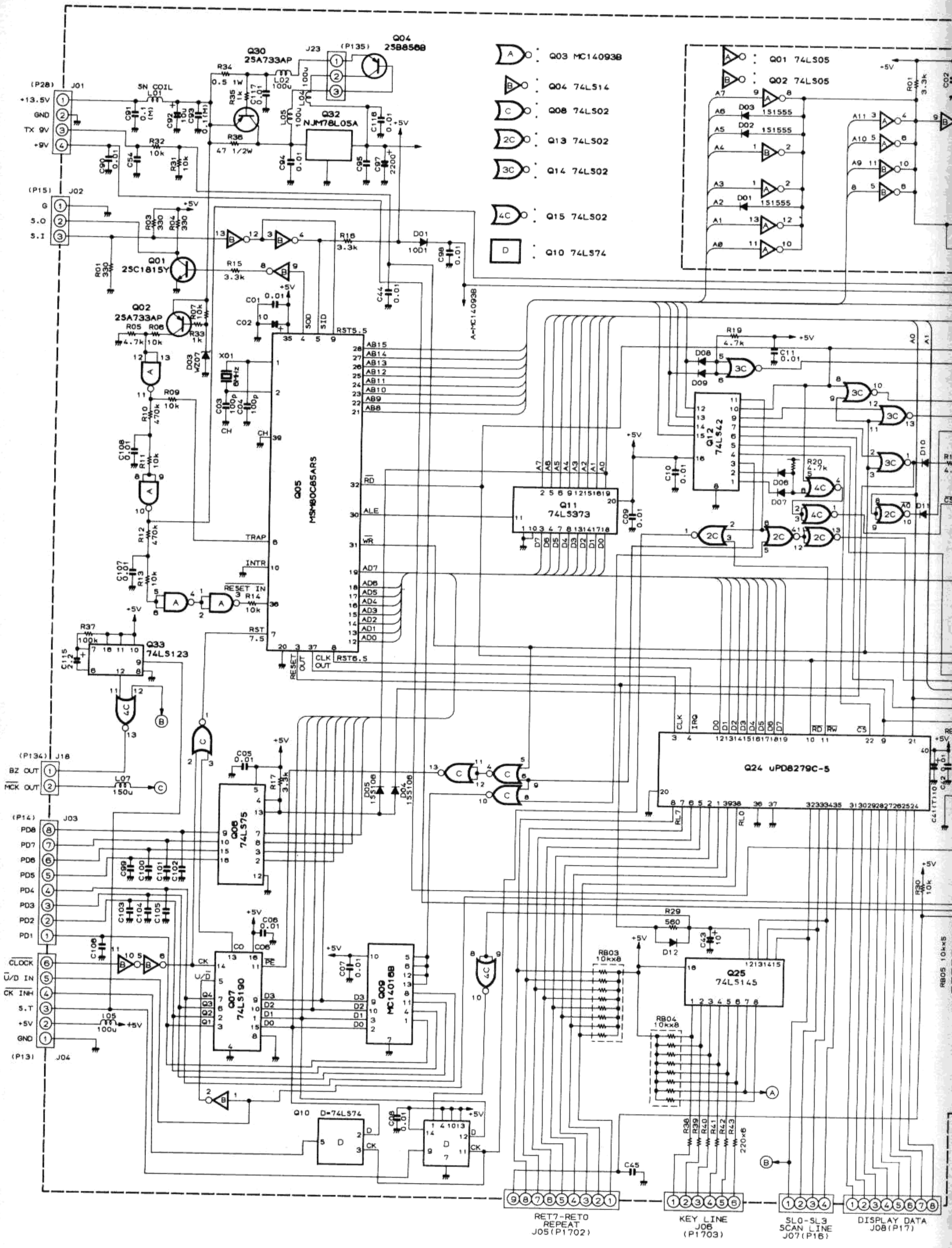

- A : Q03 MC14093B
- B : Q04 74LS14
- C : Q08 74LS02
- 2C : Q13 74LS02
- 3C : Q14 74LS02
- 4C : Q15 74LS02
- D : Q10 74LS74

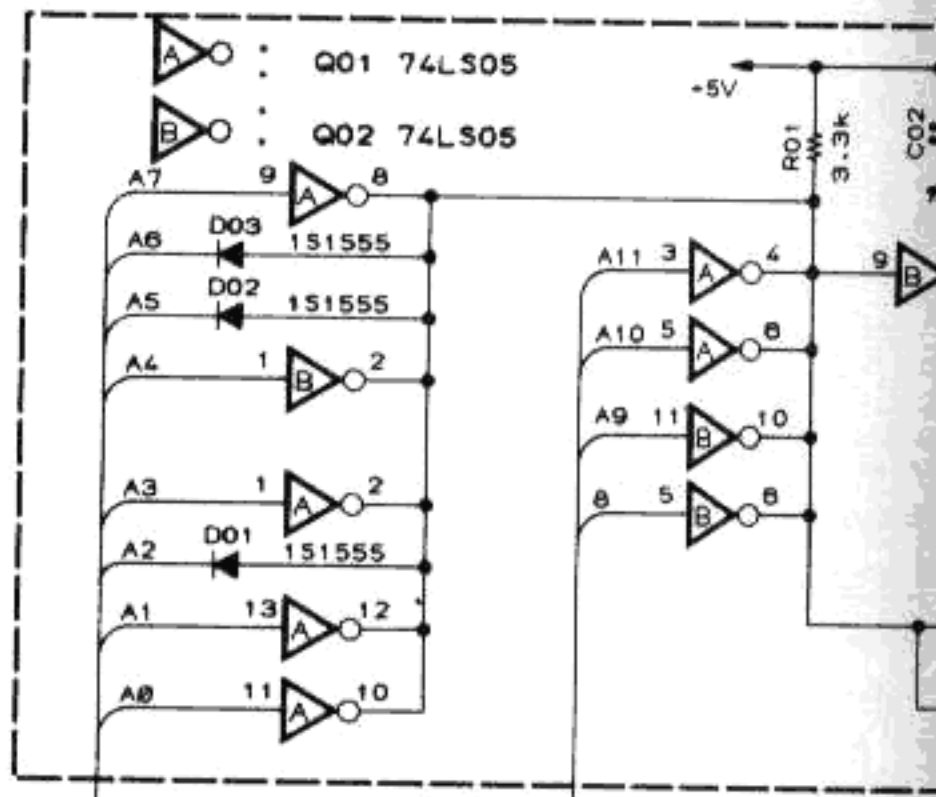

RET7-RET0 REPEAT J05 (P1702)

KEY LINE J06 (P1703)

SLO-SL3 SCAN LINE J07 (P16)

DISPLAY DATA J08 (P17)

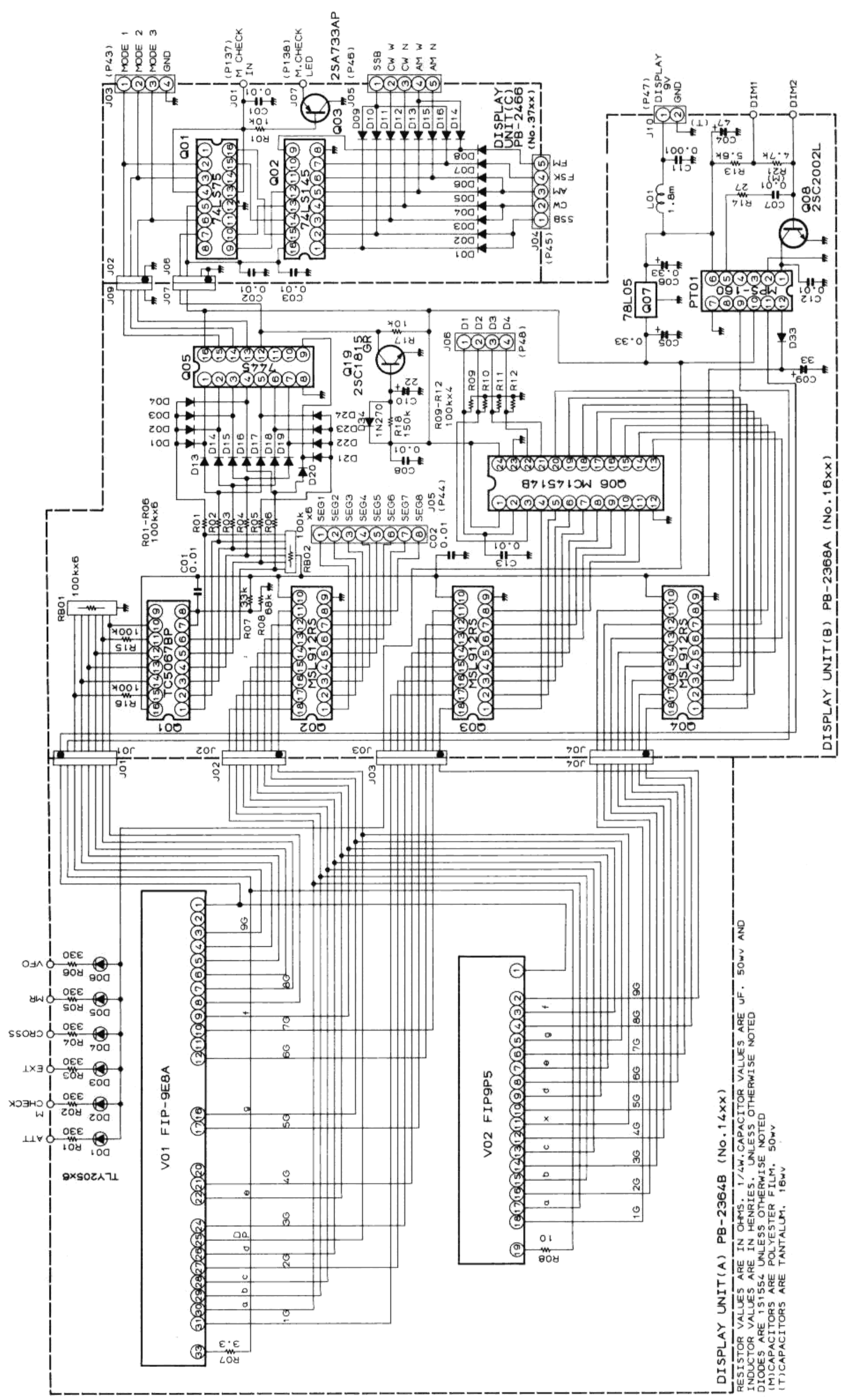

DISPLAY UNIT(A) PB-2364B (No. 14xx)
 RESISTOR VALUES ARE IN OHMS. 1/4W. CAPACITOR VALUES ARE UF. 50V AND INDUCTOR VALUES ARE IN HENRIES. UNLESS OTHERWISE NOTED DIODES ARE 1S155Z UNLESS OTHERWISE NOTED (M)CAPACITORS ARE POLYESTER FILM, 50V (T)CAPACITORS ARE TANTALUM, 16V

DISPLAY UNIT (B) PB-2368A (No. 16xx)

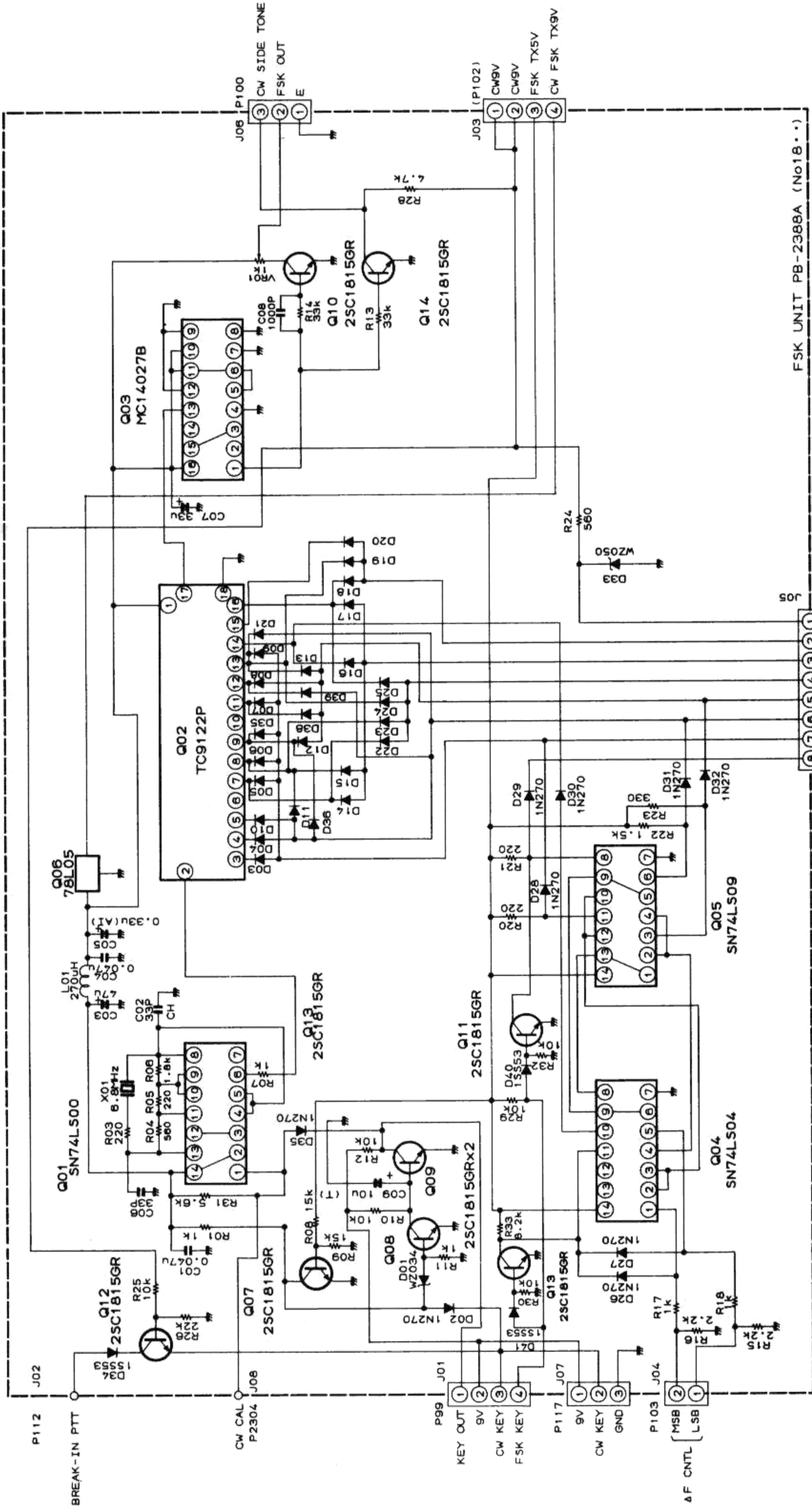

FSK UNIT PB-2388A (No18..)

FSK A/F CNTL

IN	FREQUENCY	1/N
0 0	RESET	
0 1	2550Hz	666
1 0	2975Hz	571
1 1	2295Hz	740
CW	500Hz	3400
	600Hz	2830
	700Hz	2430

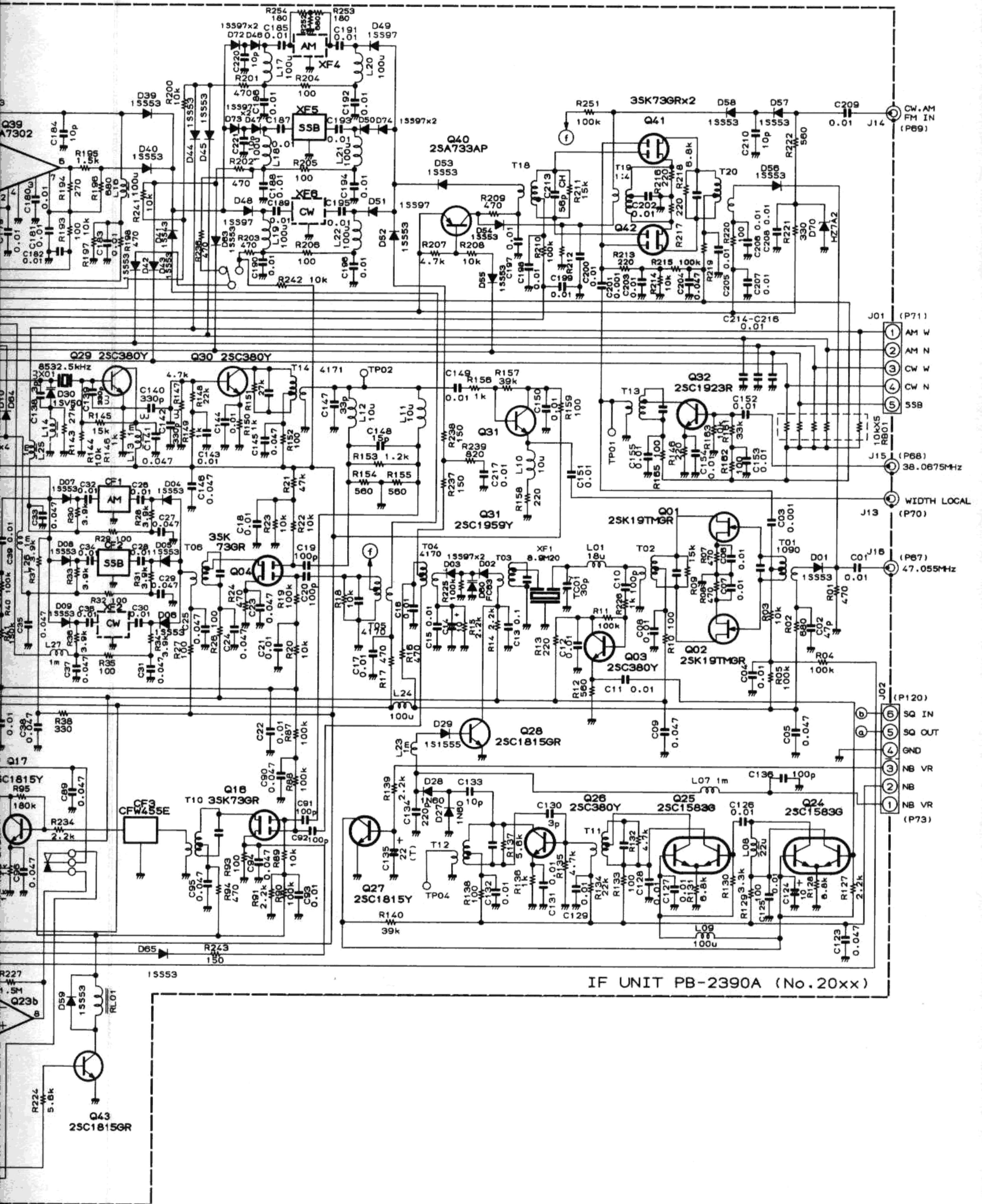

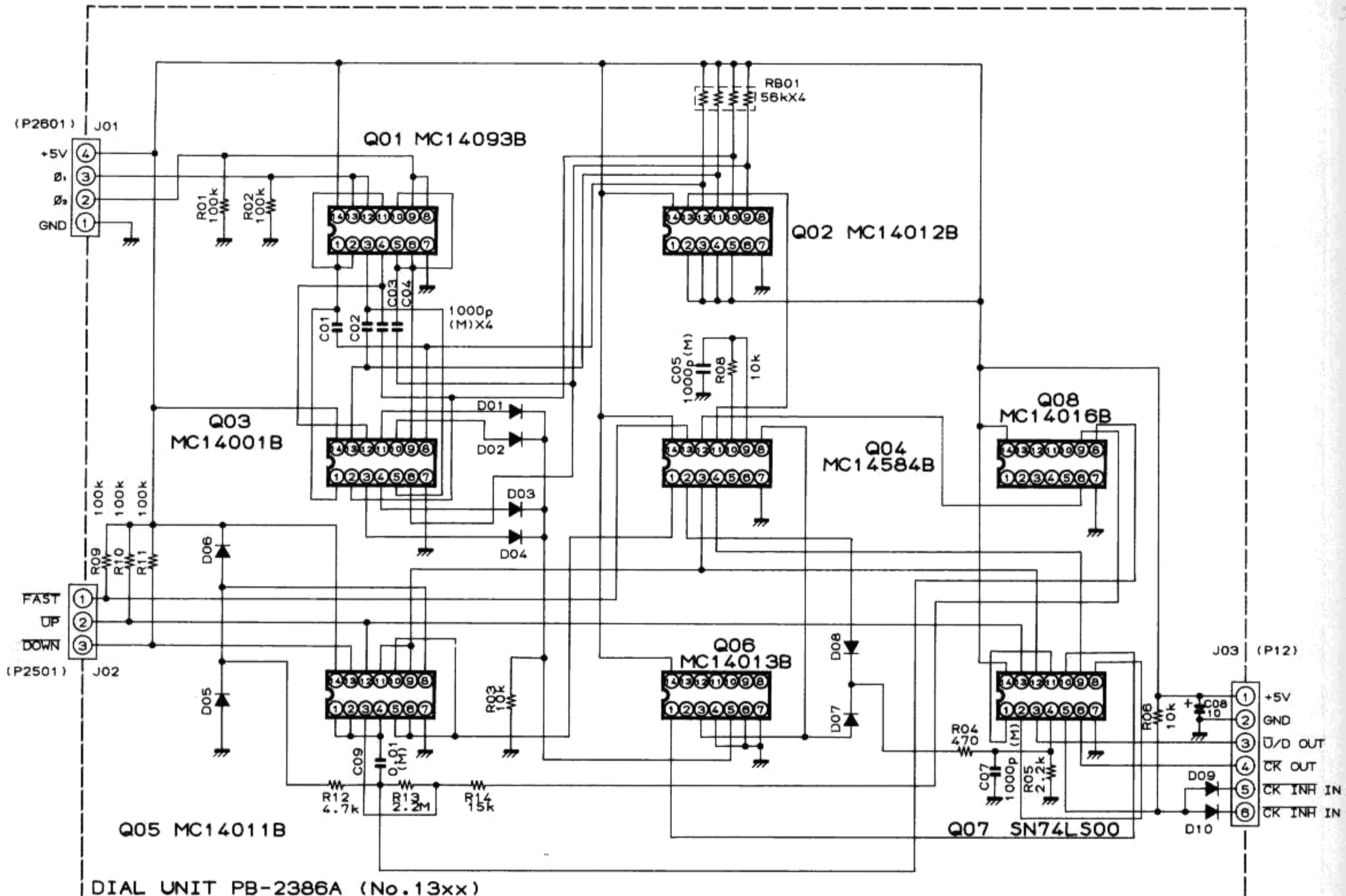

DIAL UNIT PB-2386A (No.13xx)

RESISTOR VALUES ARE IN OHMS, 1/4W. CAPACITOR VALUES ARE IN uF, 50V AND INDUCTOR VALUES ARE IN HENRIES, UNLESS OTHERWISE NOTED
 DIODES ARE 1S1555
 (M) CAPACITORS ARE POLYESTER FILM TYPE, 50V

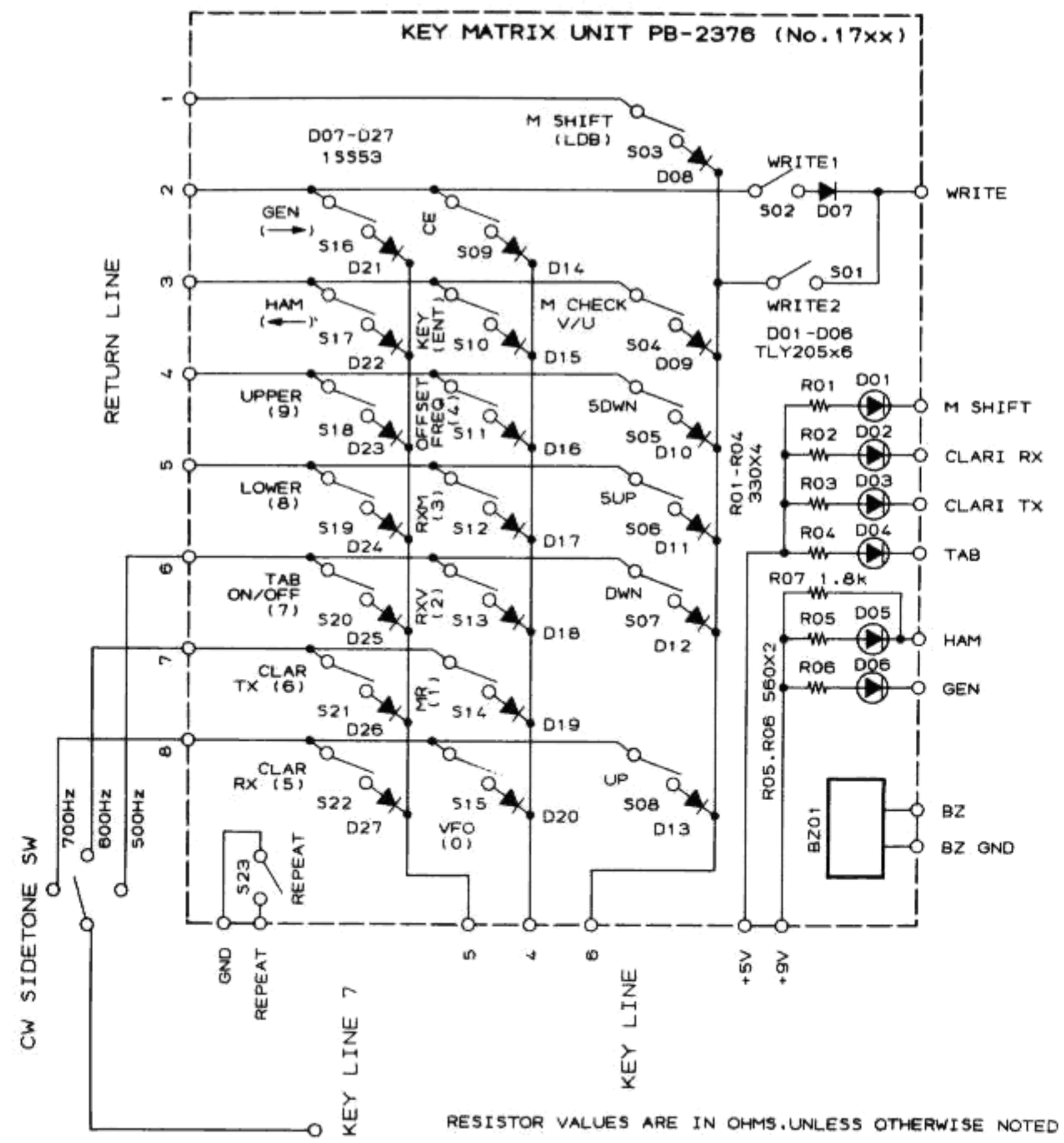

RESISTOR VALUES ARE IN OHMS, UNLESS OTHERWISE NOTED

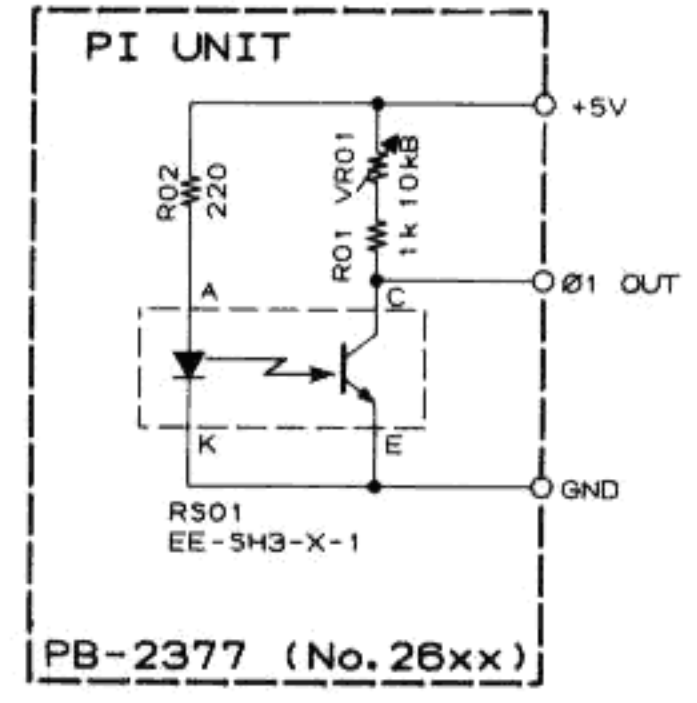

PB-2377 (No.26xx)

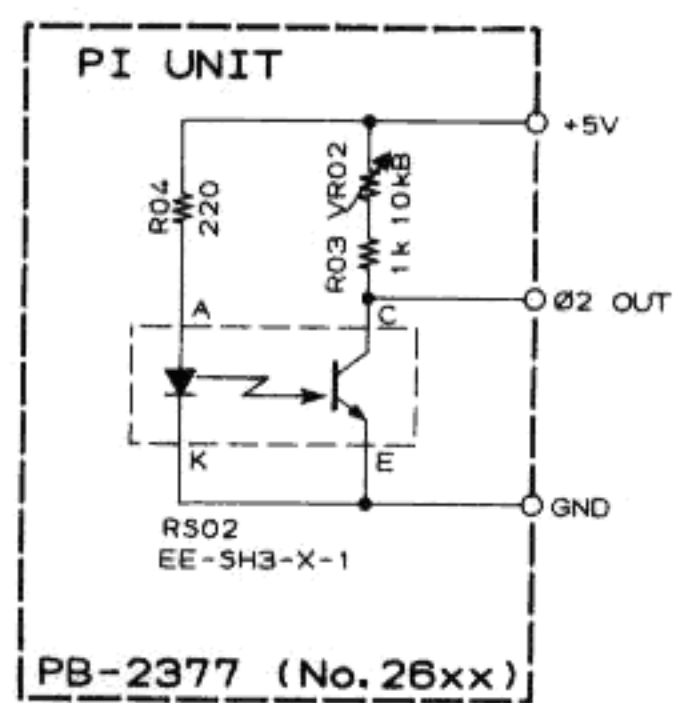

PB-2377 (No.26xx)

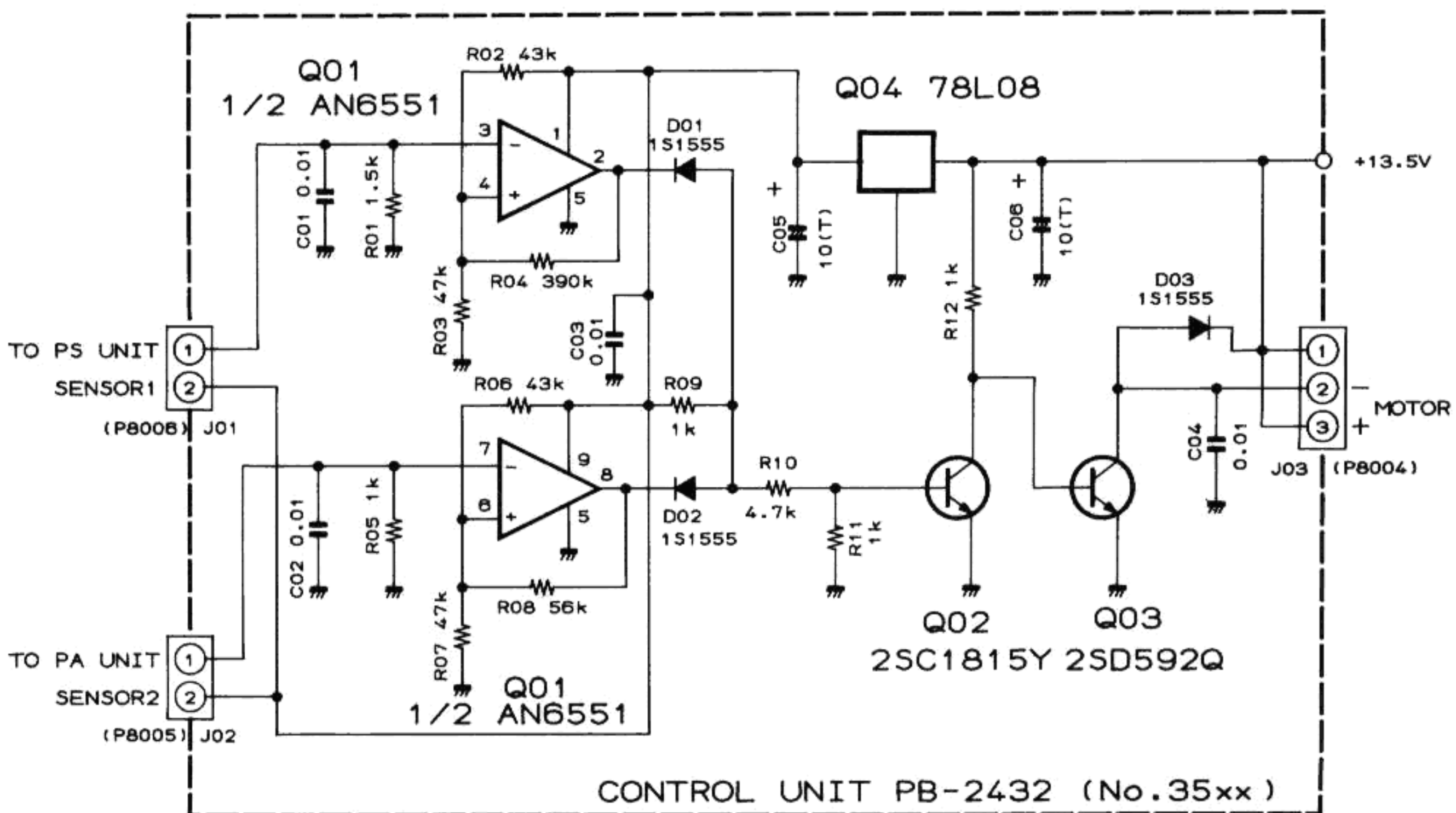
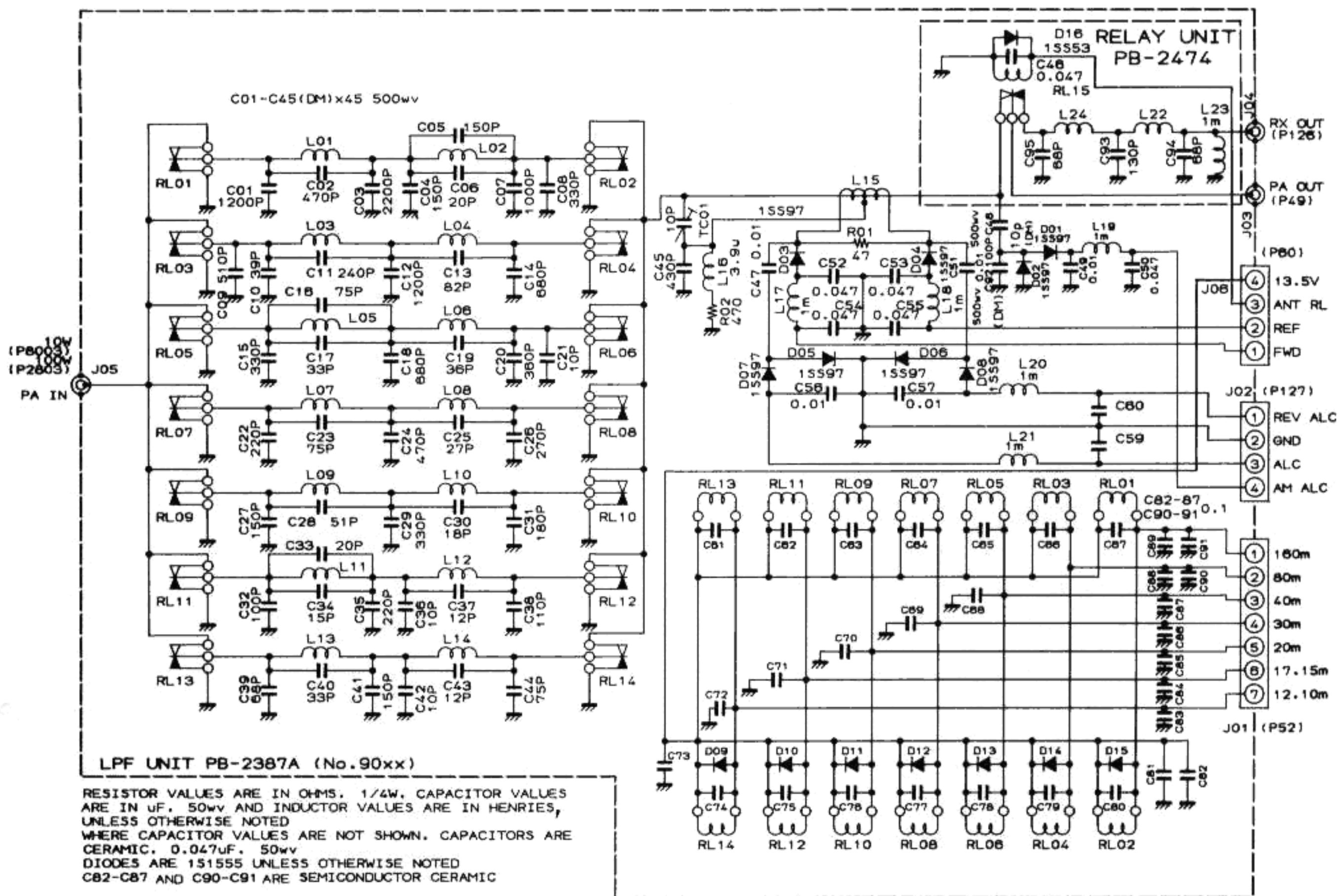

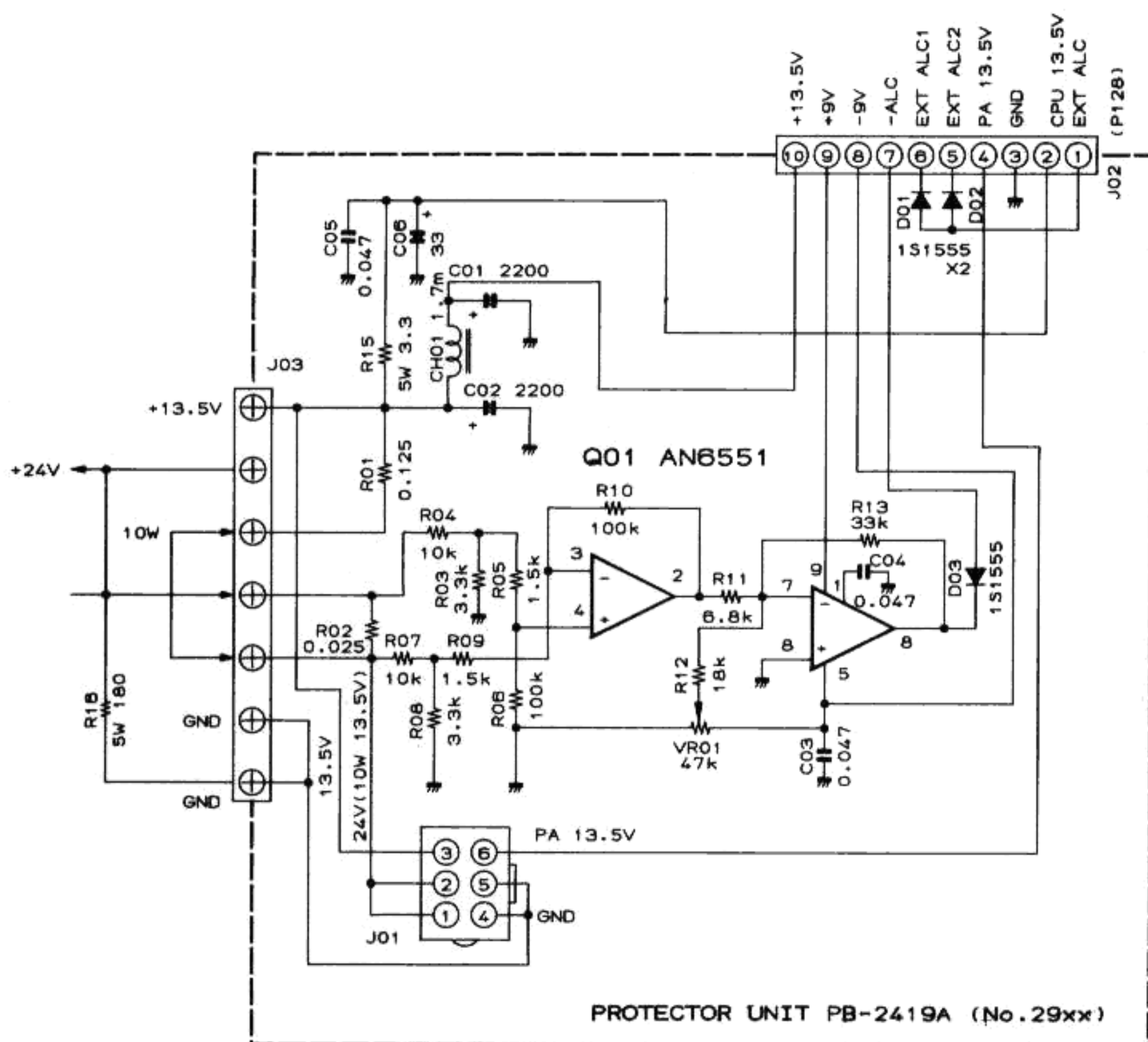

RESISTOR VALUES ARE IN OHMS. 1/4W, CAPACITOR VALUES ARE IN uF. 50Vv. AND INDUCTOR VALUES ARE IN HENRIES. UNLESS OTHERWISE NOTED

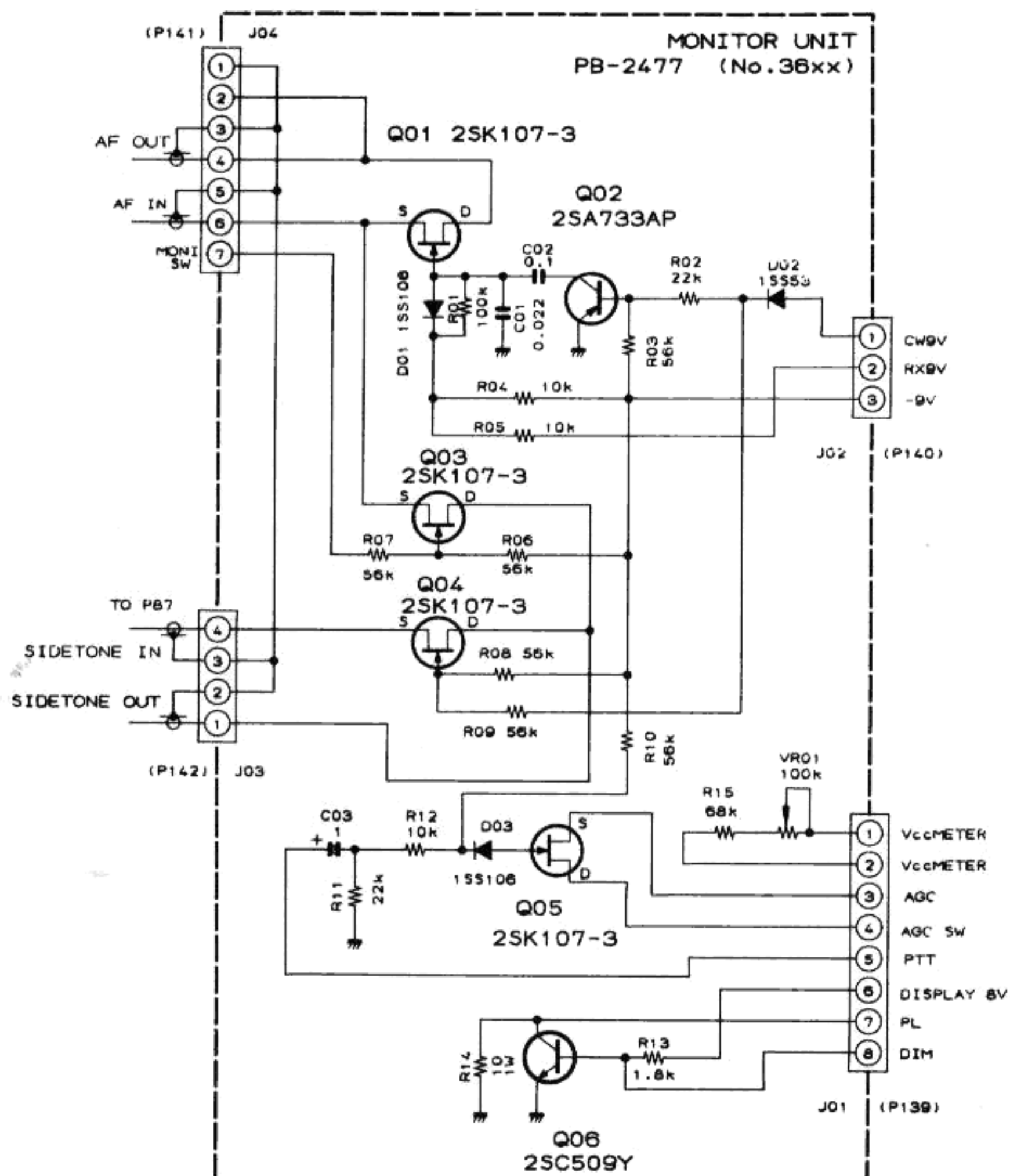

RESISTOR VALUES ARE IN OHMS. 1/4W AND CAPACITOR VALUES ARE IN uF. 50Vv. UNLESS OTHERWISE NOTED

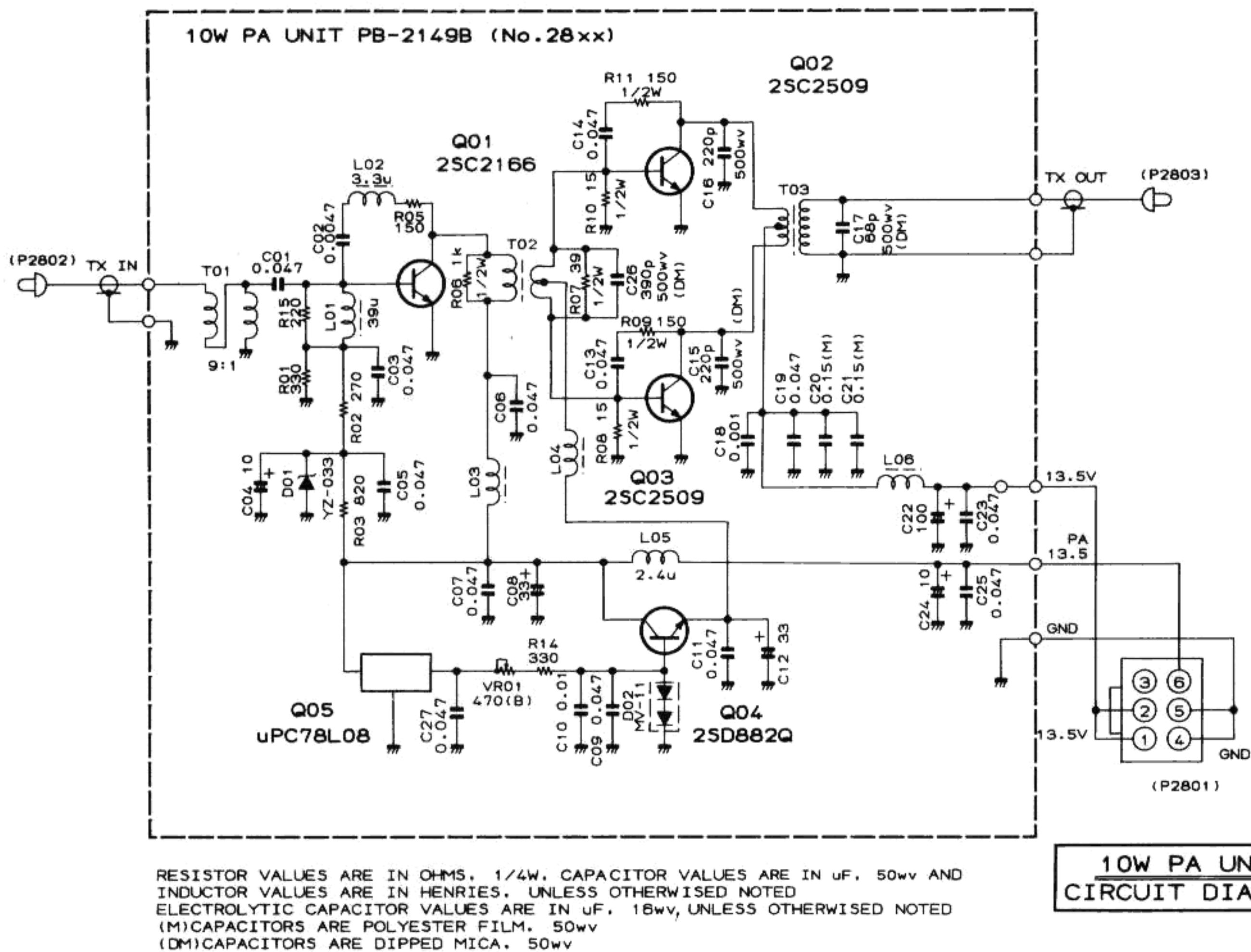
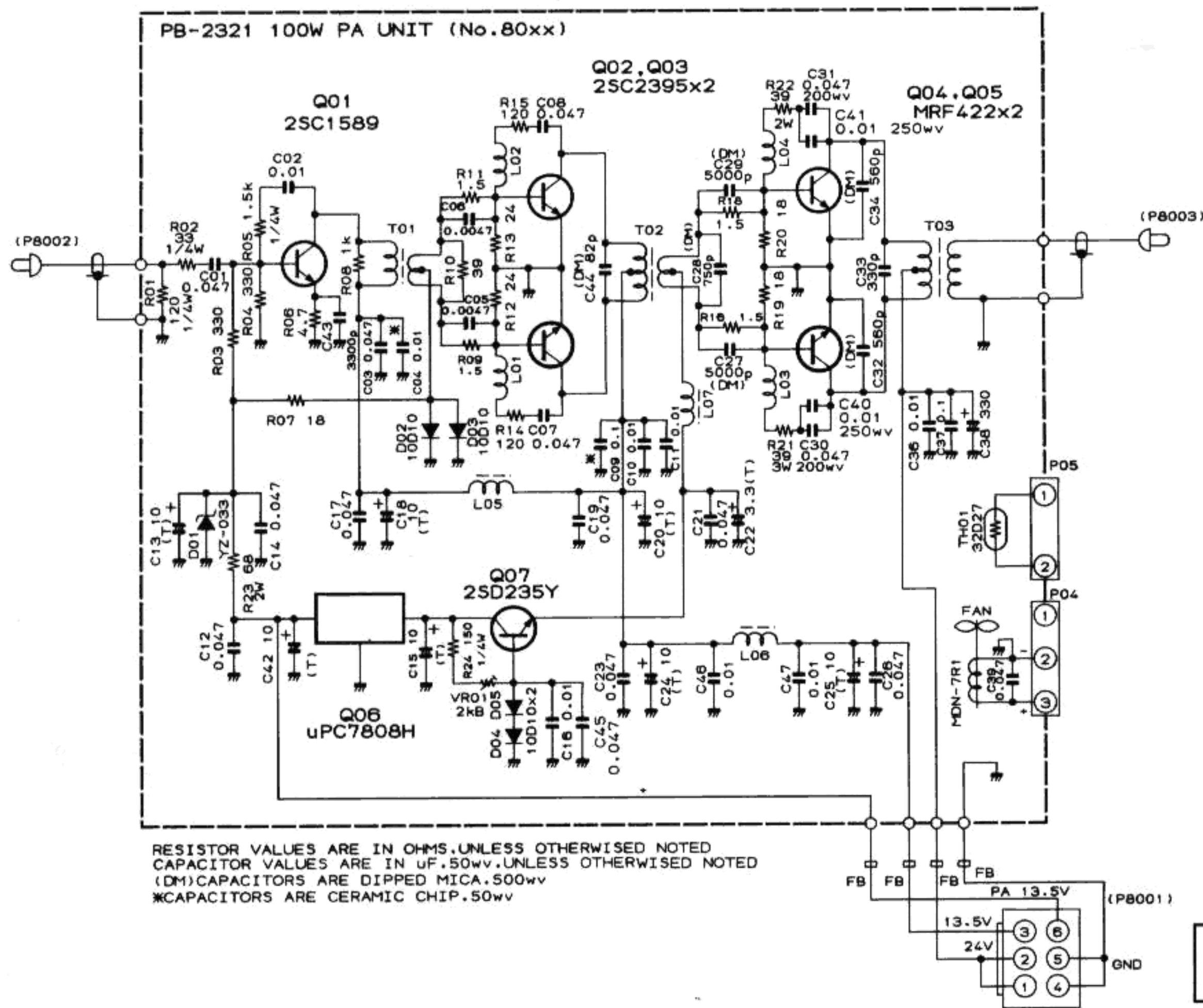

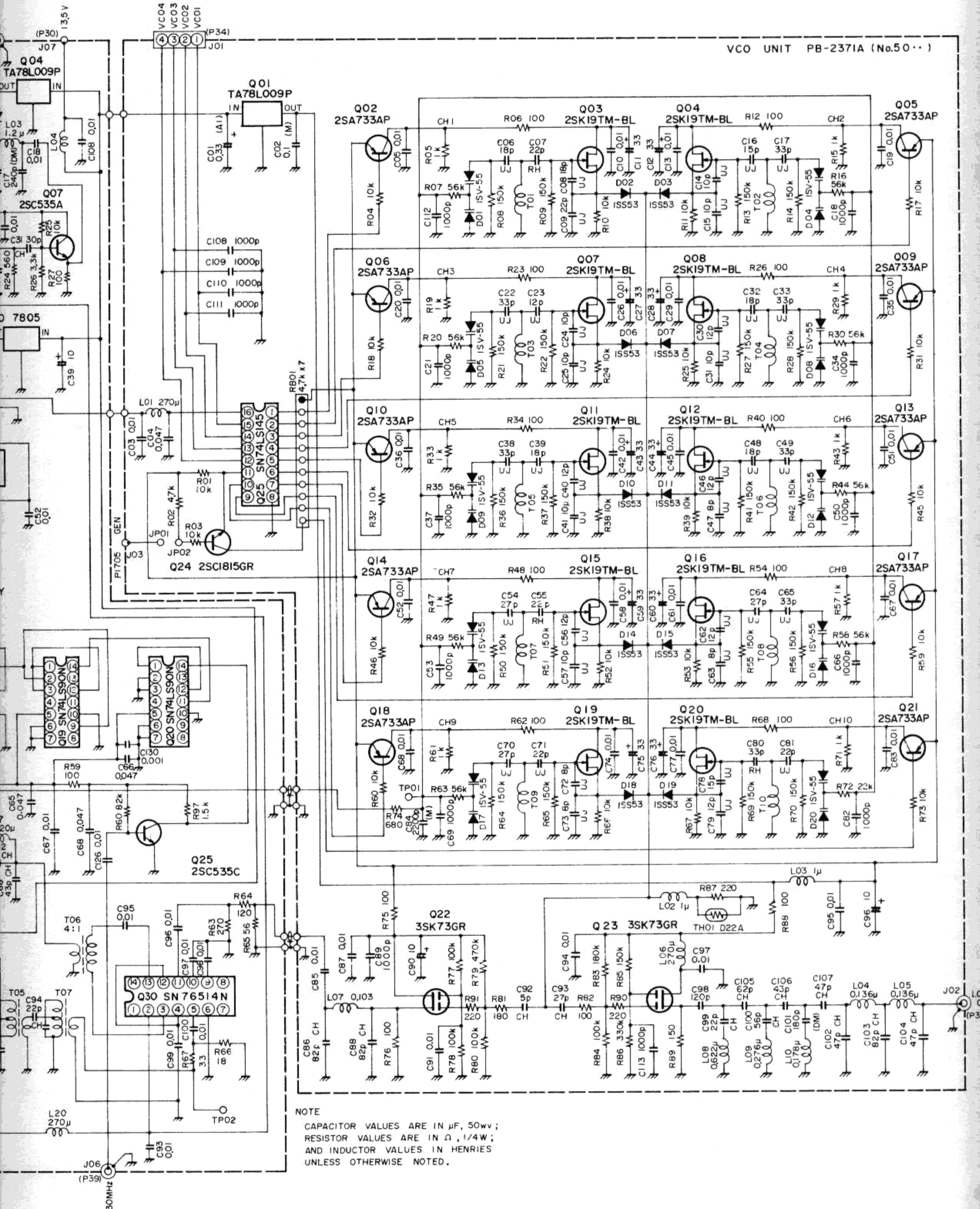

NOTE
 CAPACITOR VALUES ARE IN μF , 50WV;
 RESISTOR VALUES ARE IN Ω , 1/4W;
 AND INDUCTOR VALUES IN HENRIES
 UNLESS OTHERWISE NOTED.

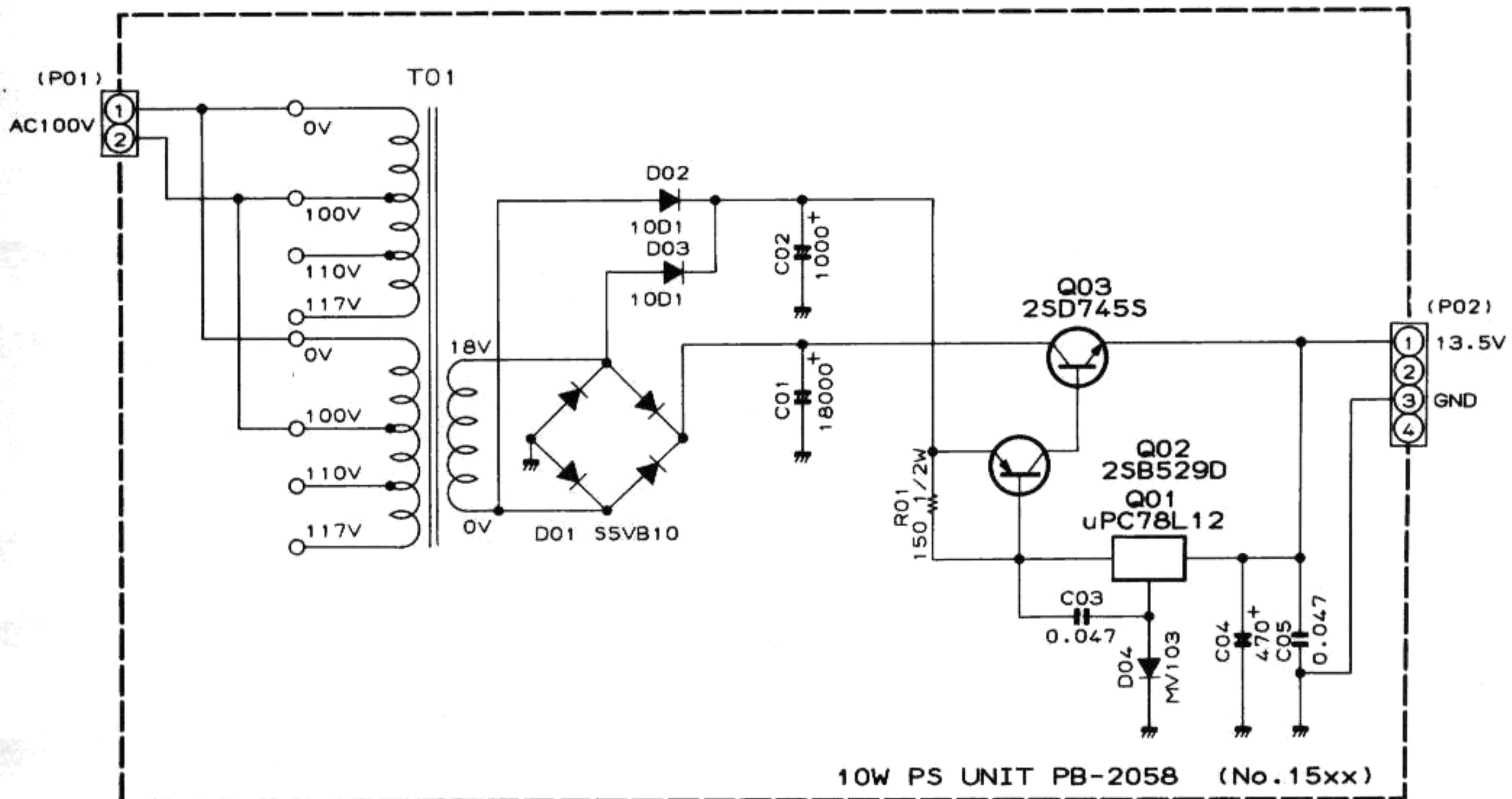
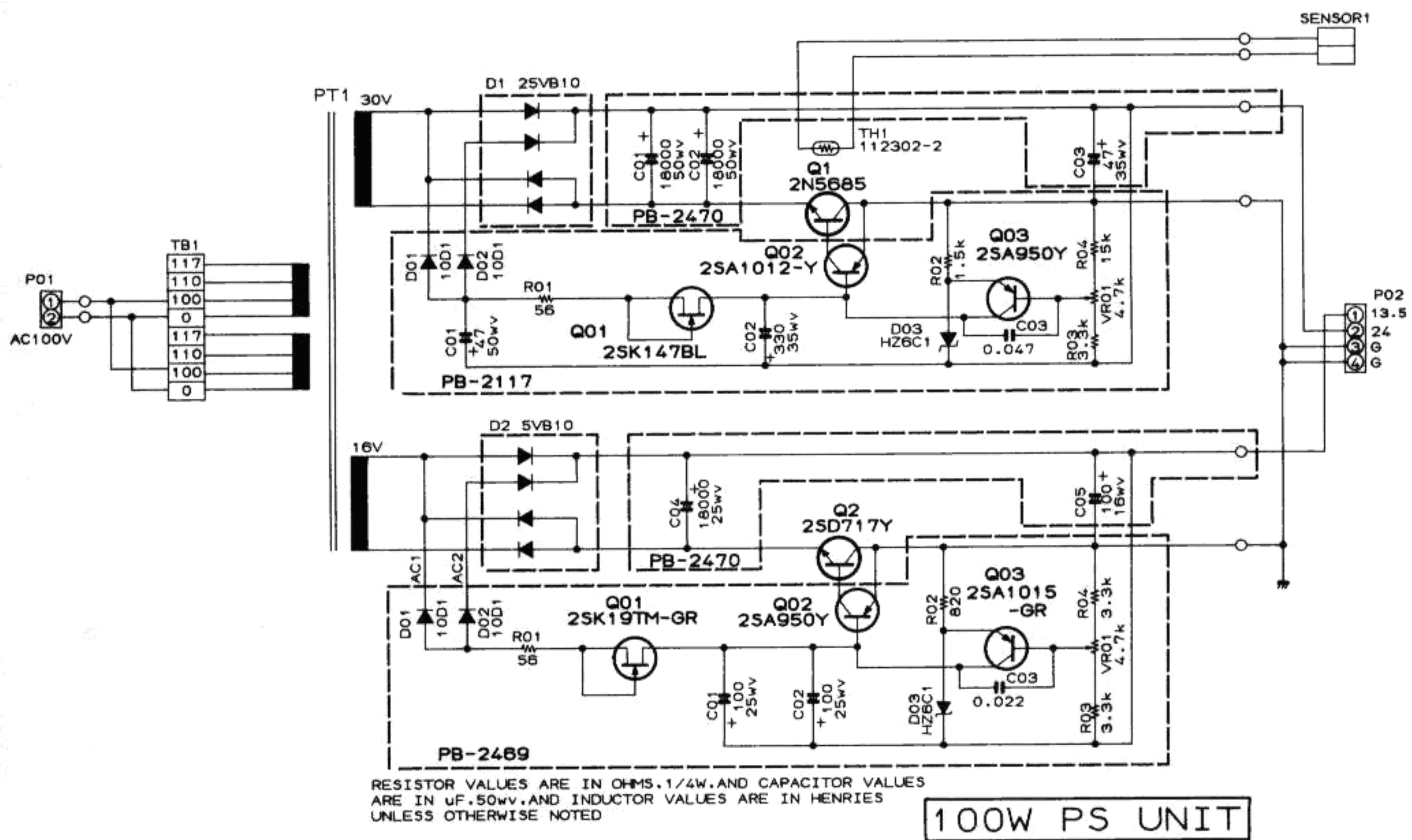

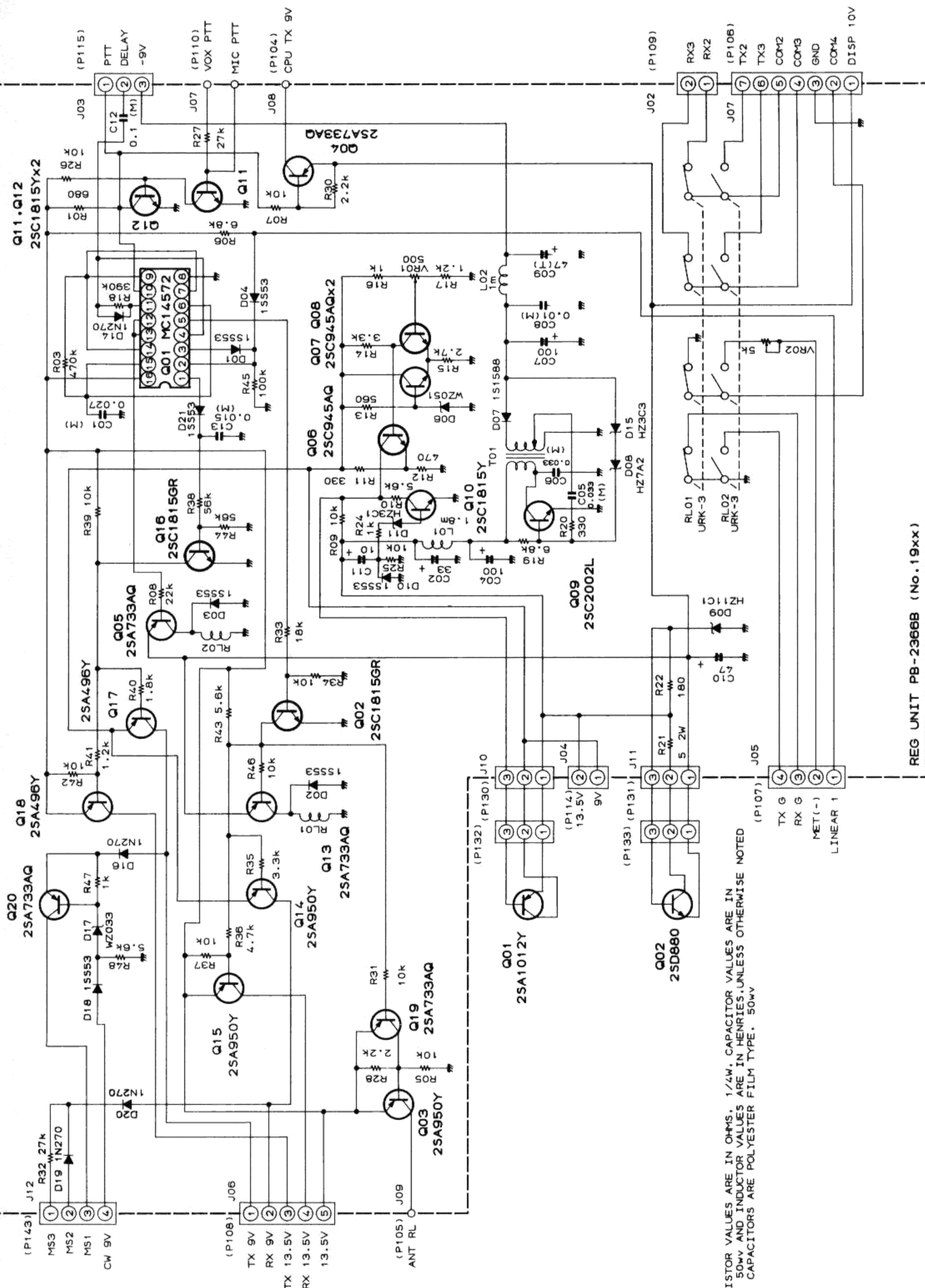

REG UNIT PB-2366B (No. 19xx)

RESISTOR VALUES ARE IN OHMS, 1/4W. CAPACITOR VALUES ARE IN UF. 50WV AND INDUCTOR VALUES ARE IN HENRIES, UNLESS OTHERWISE NOTED (M) CAPACITORS ARE POLYESTER FILM TYPE, 50WV

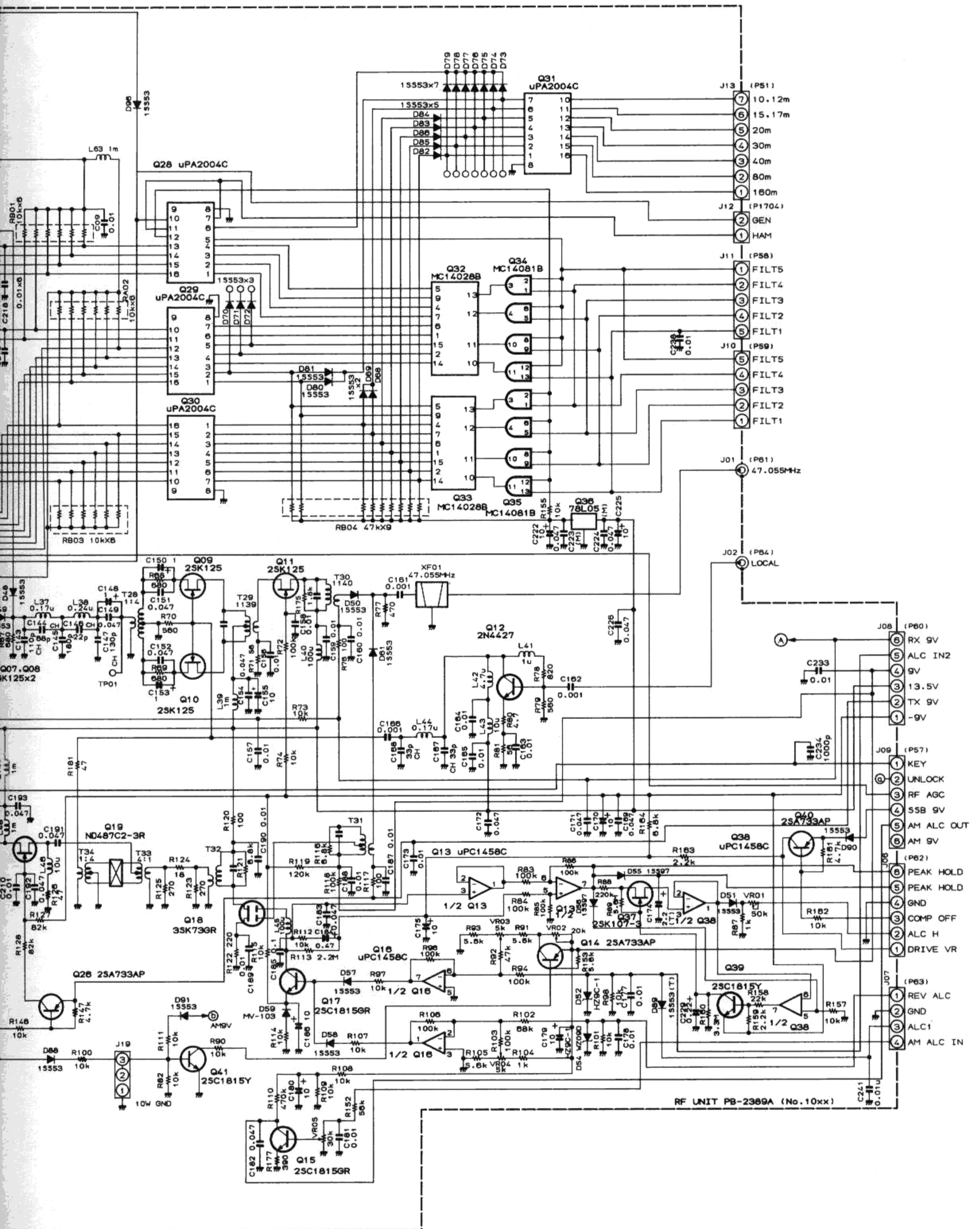

RF UNIT PB-2389A (No. 10xx)

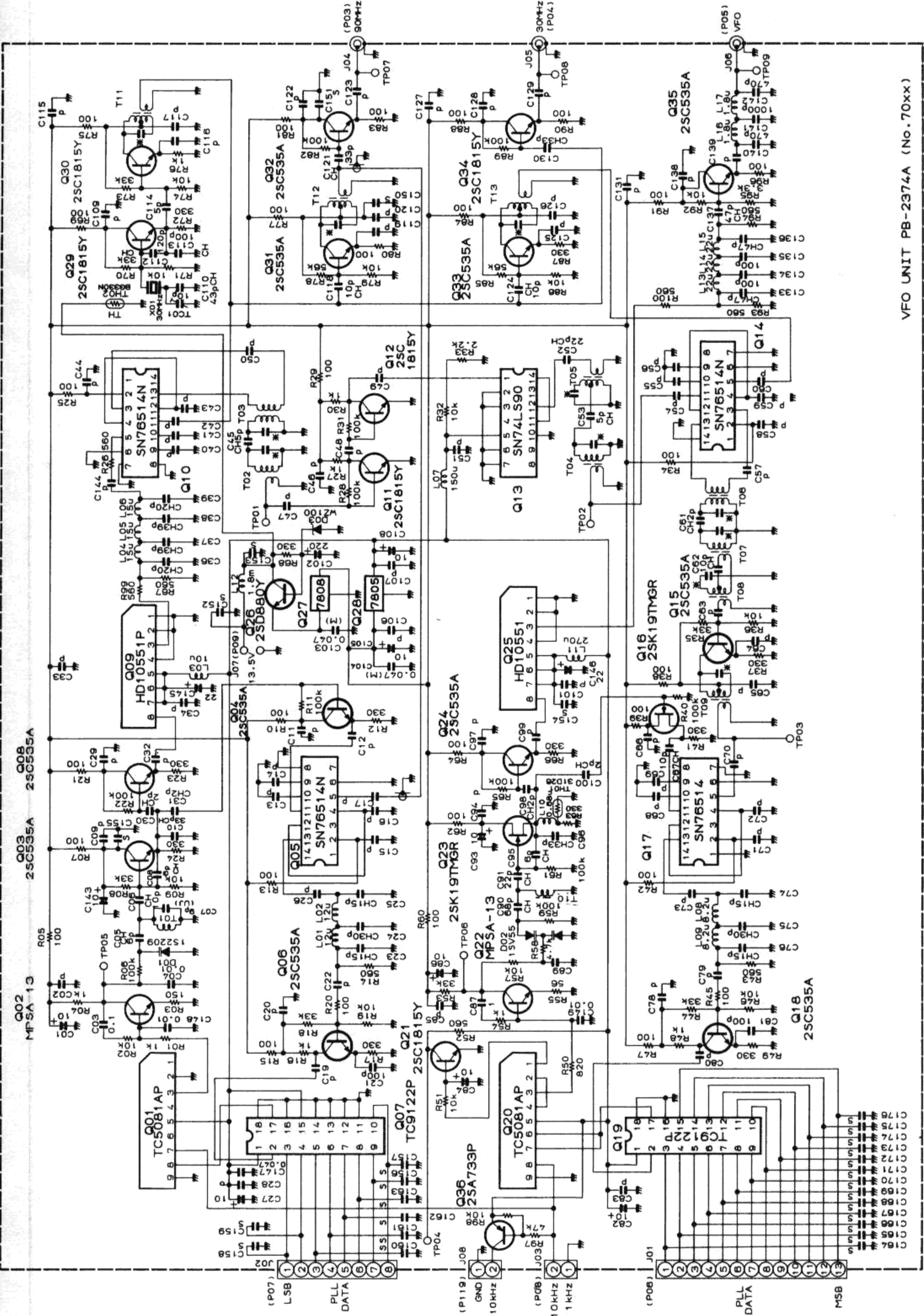

VFO UNIT PB-2374A (No. 70xx)

RESISTOR VALUES ARE IN OHMS, 1/4W, AND CAPACITOR VALUES ARE UF, 50V, AND
 INDUCTOR VALUES ARE IN HENRIES, UNLESS OTHERWISE NOTED
 (P) CAPACITORS ARE 0.01UF, 50V
 (S) CAPACITORS ARE 0.001UF, 50V
 CAPACITORS WISE * ARE INCLUDING THE COIL

PLL/VCO UNIT

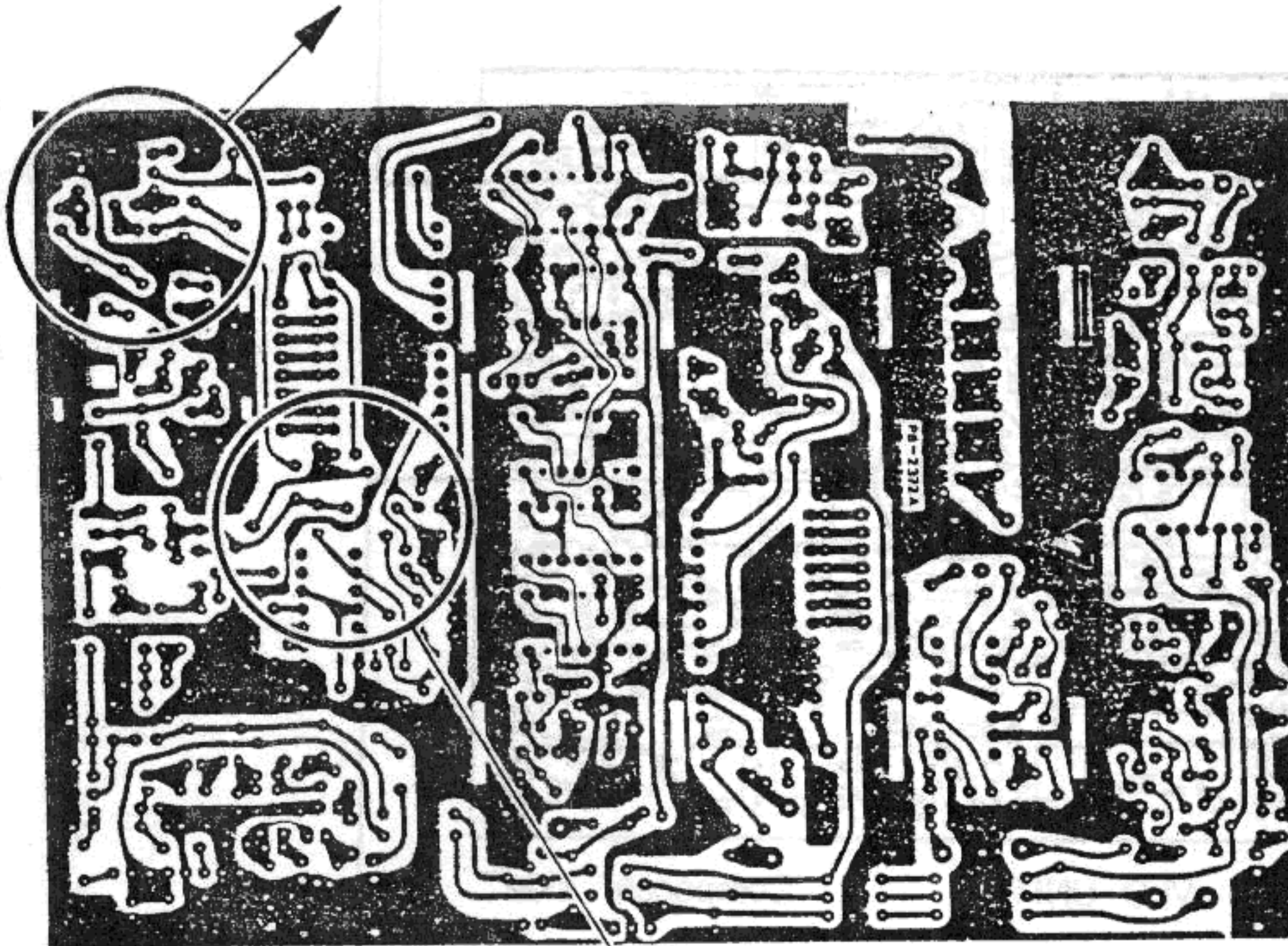
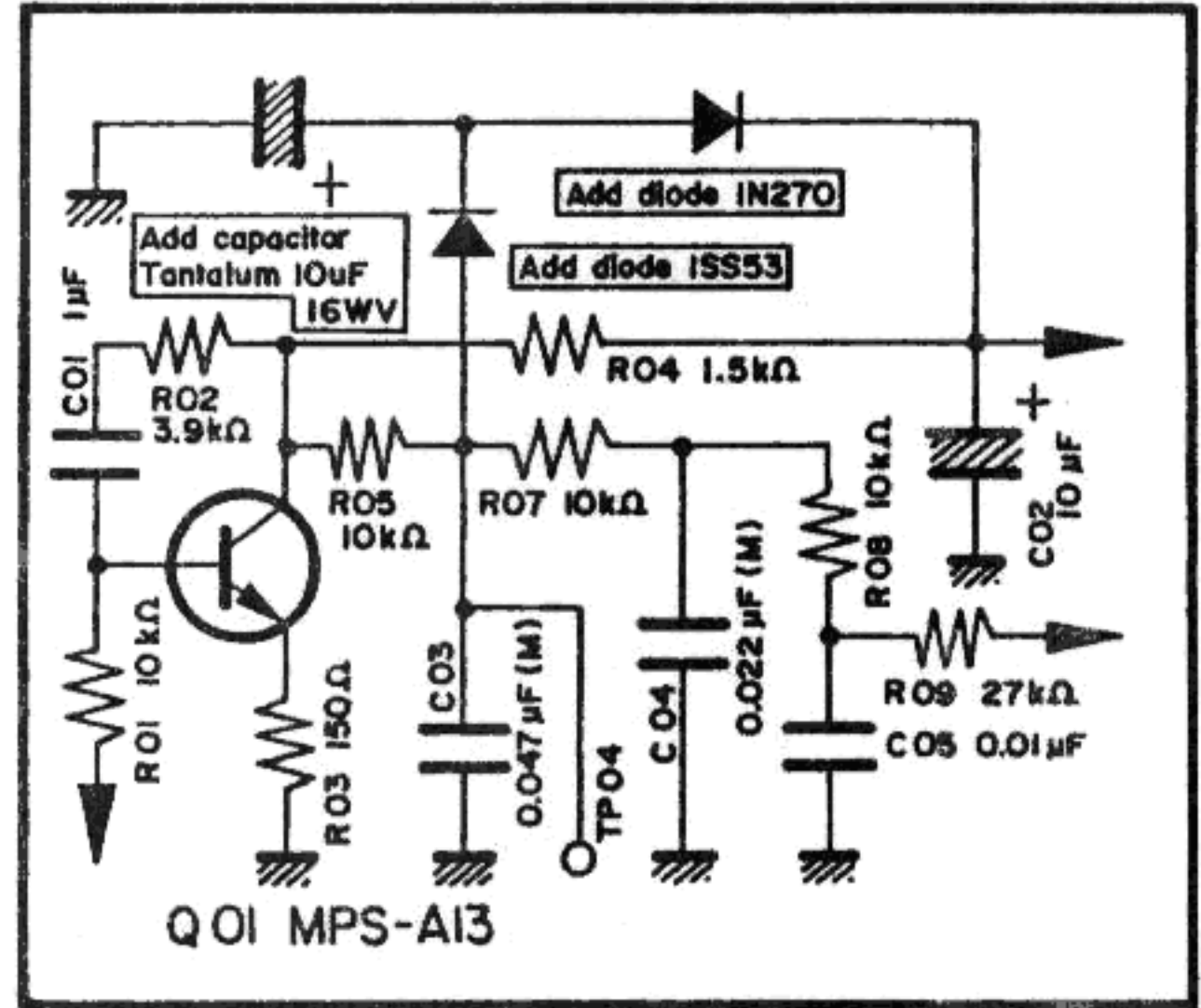
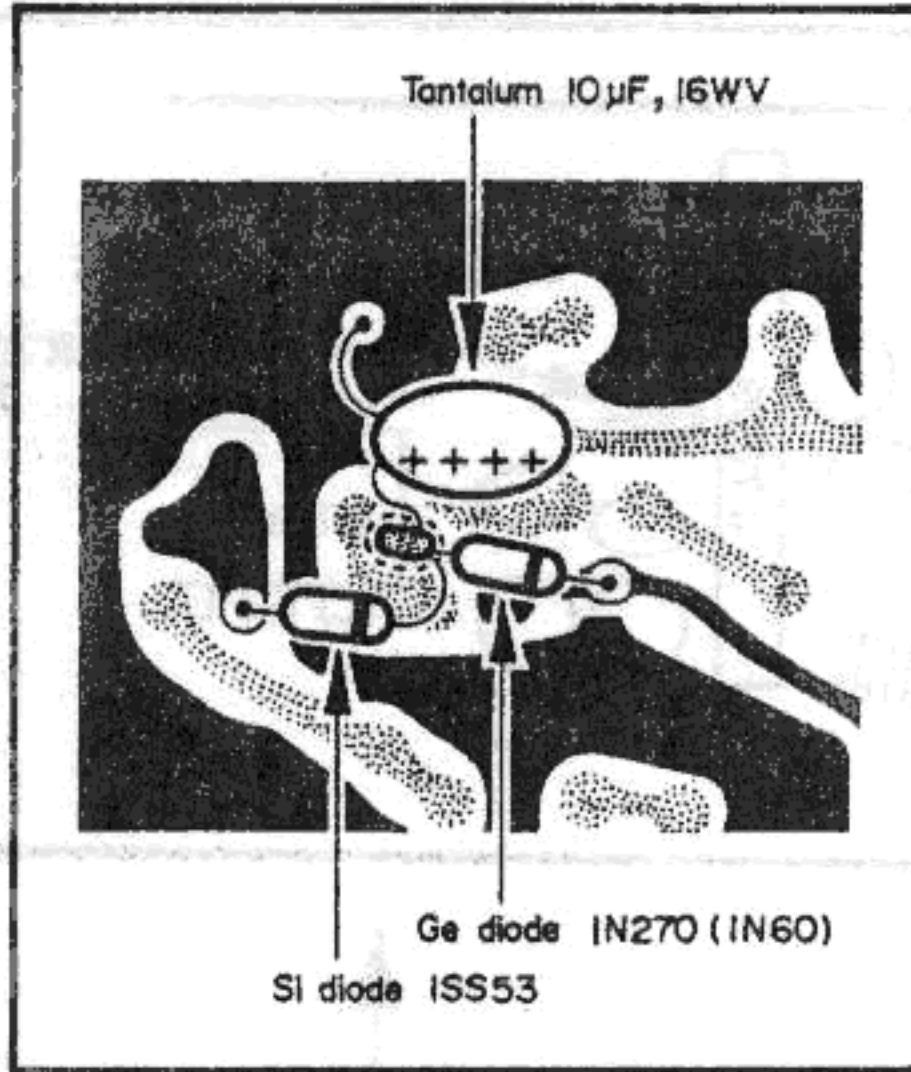

PLL/VCO UNIT Solder side

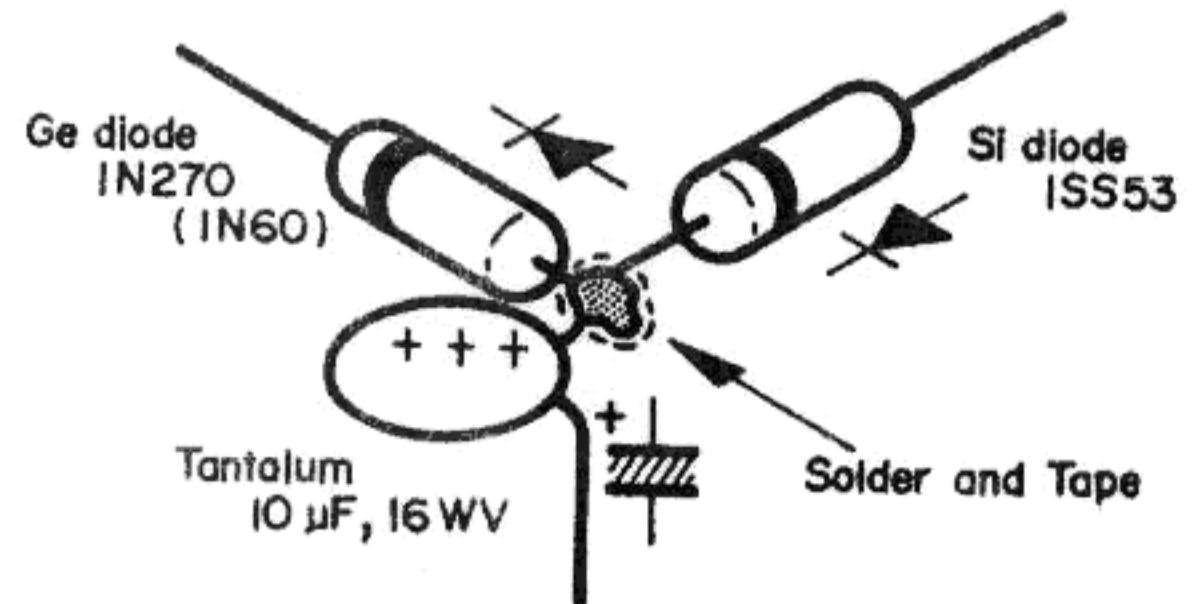
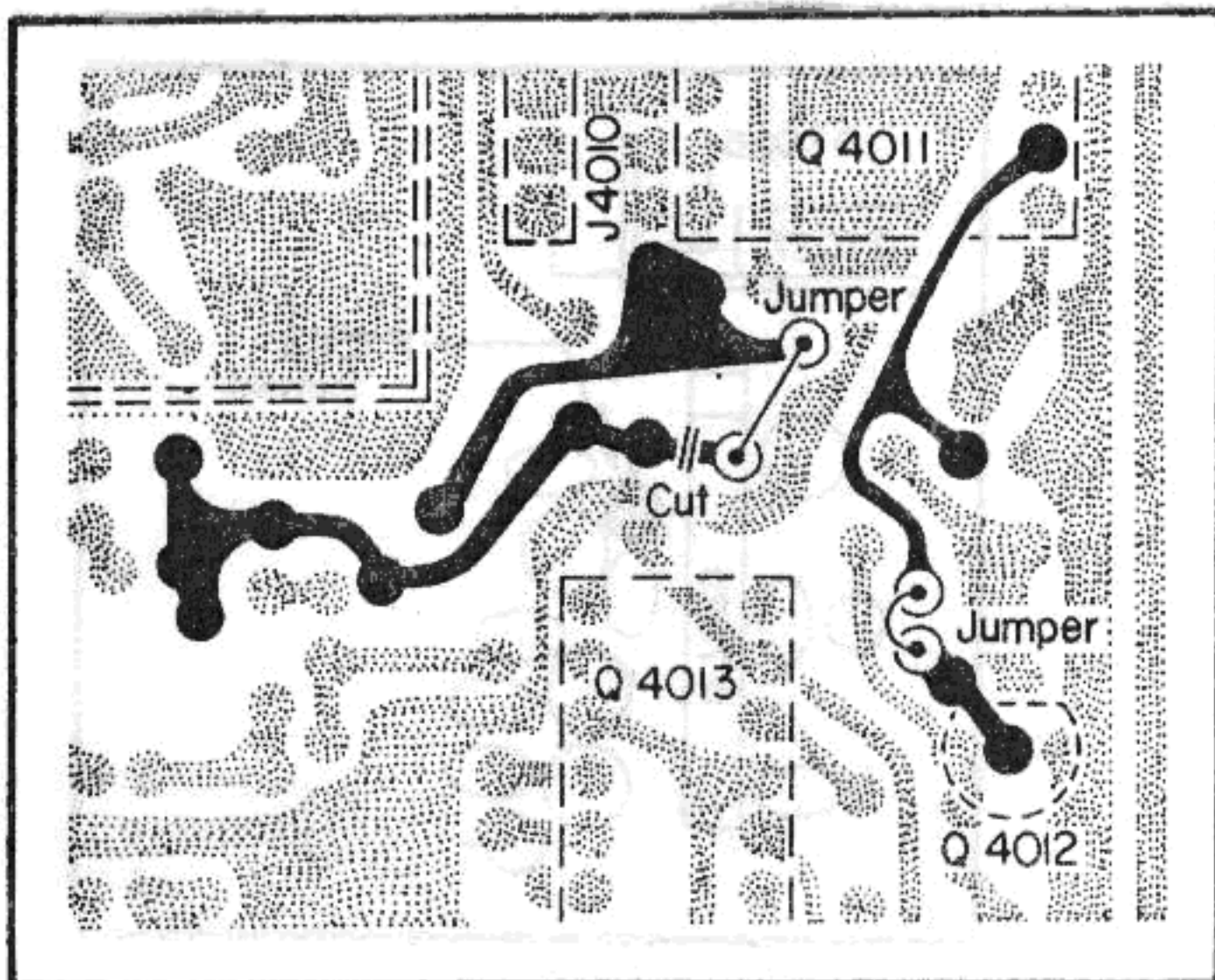

PLL/VCO UNIT

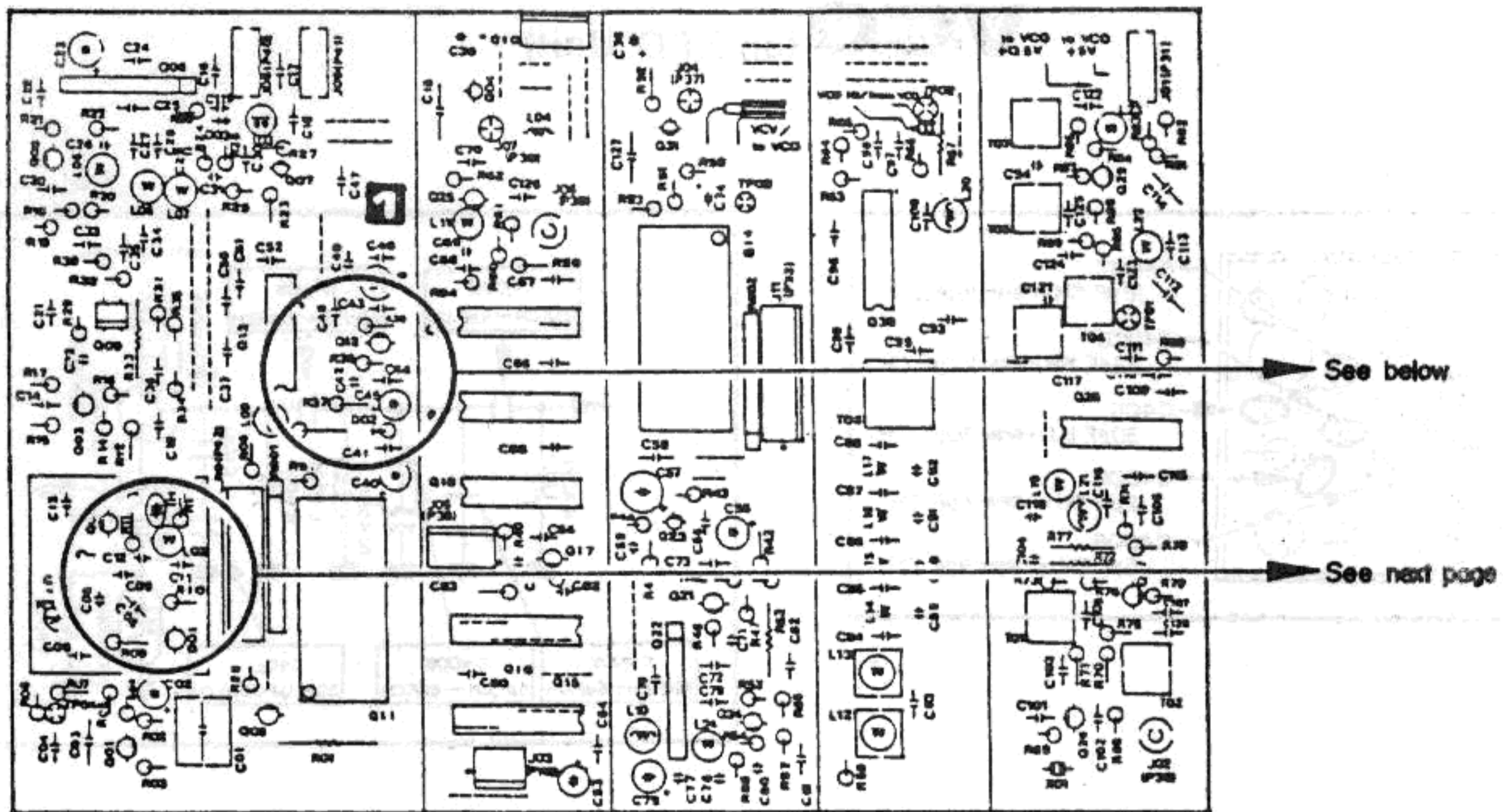

PLL/VCO UNIT

Component side

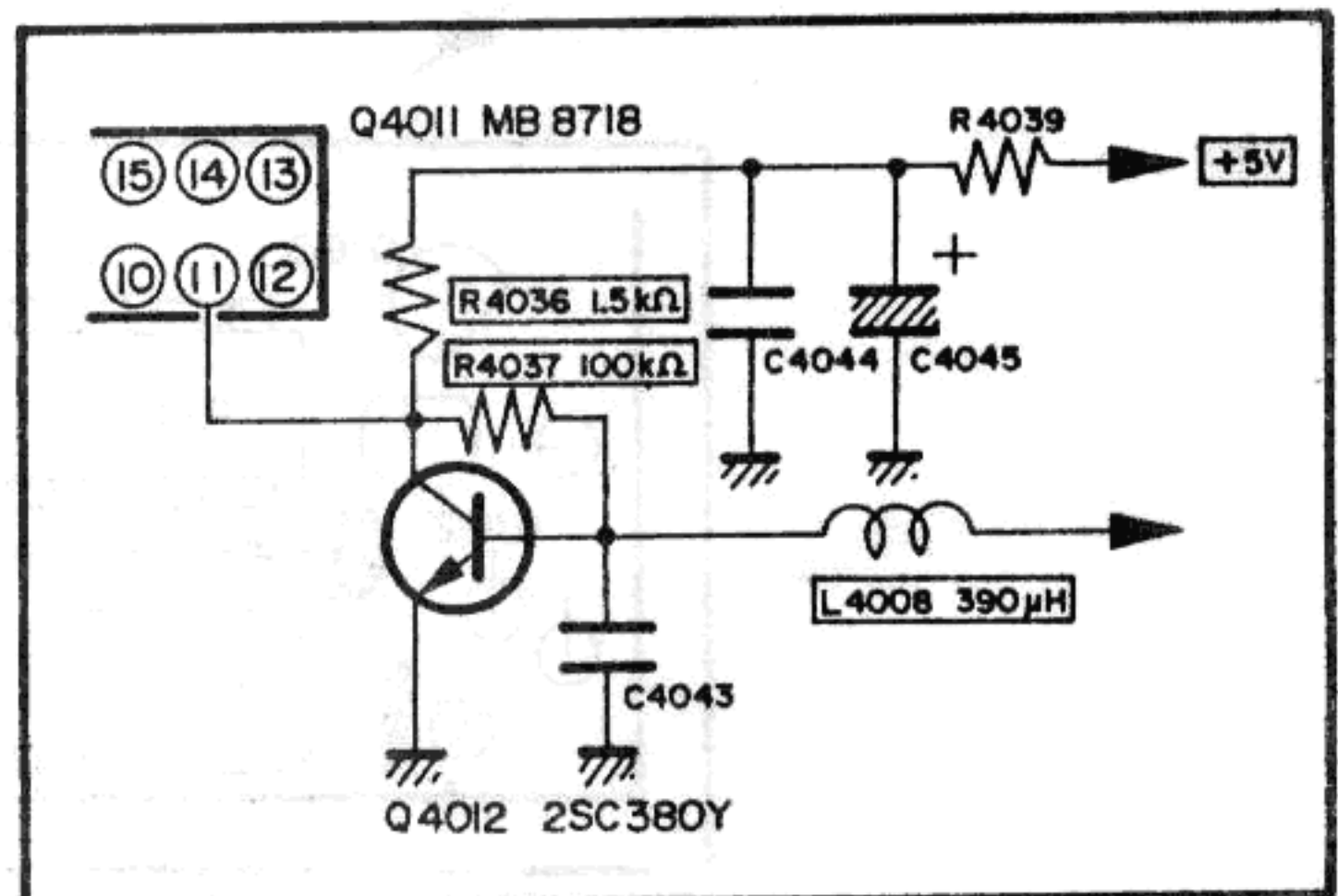
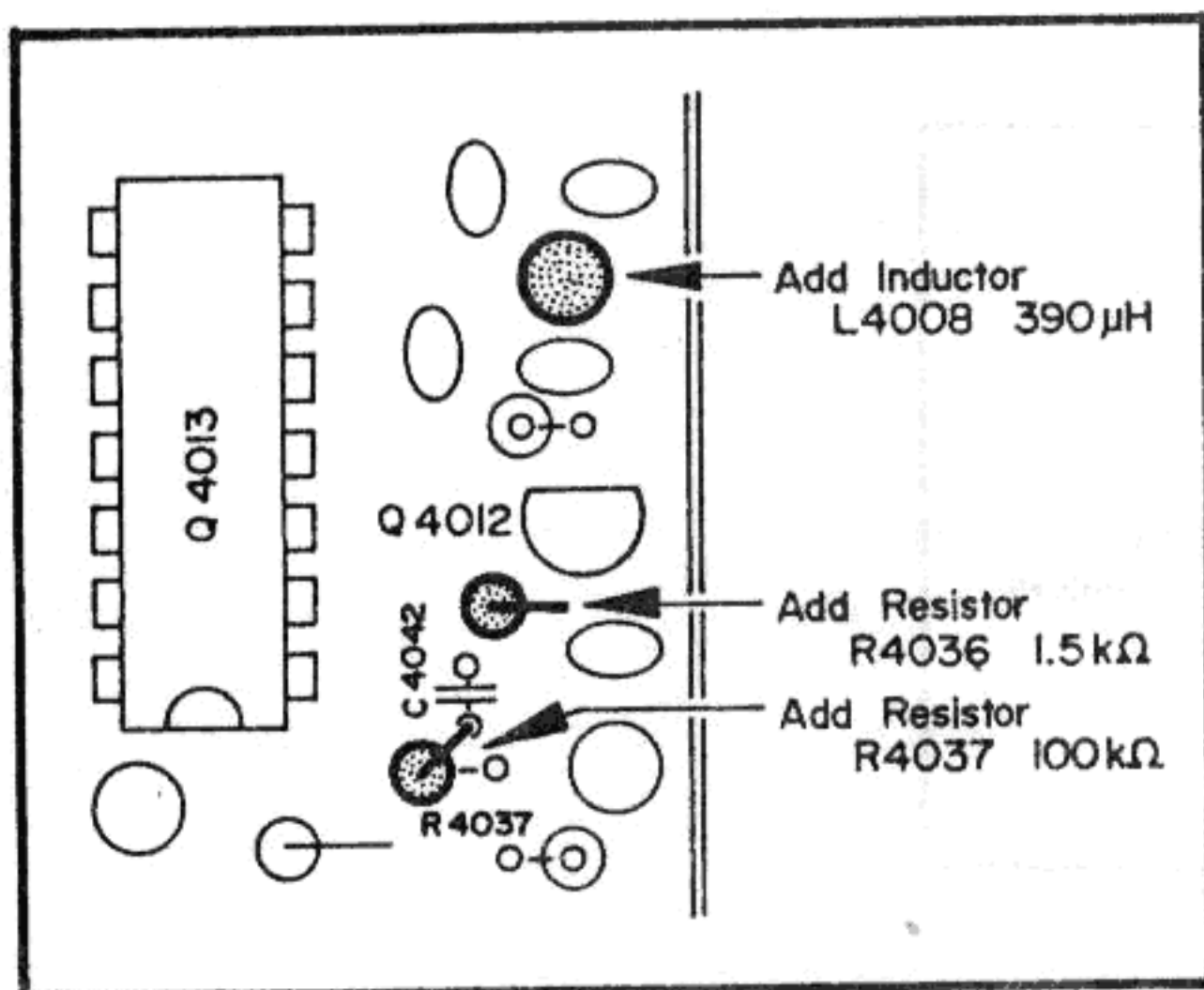
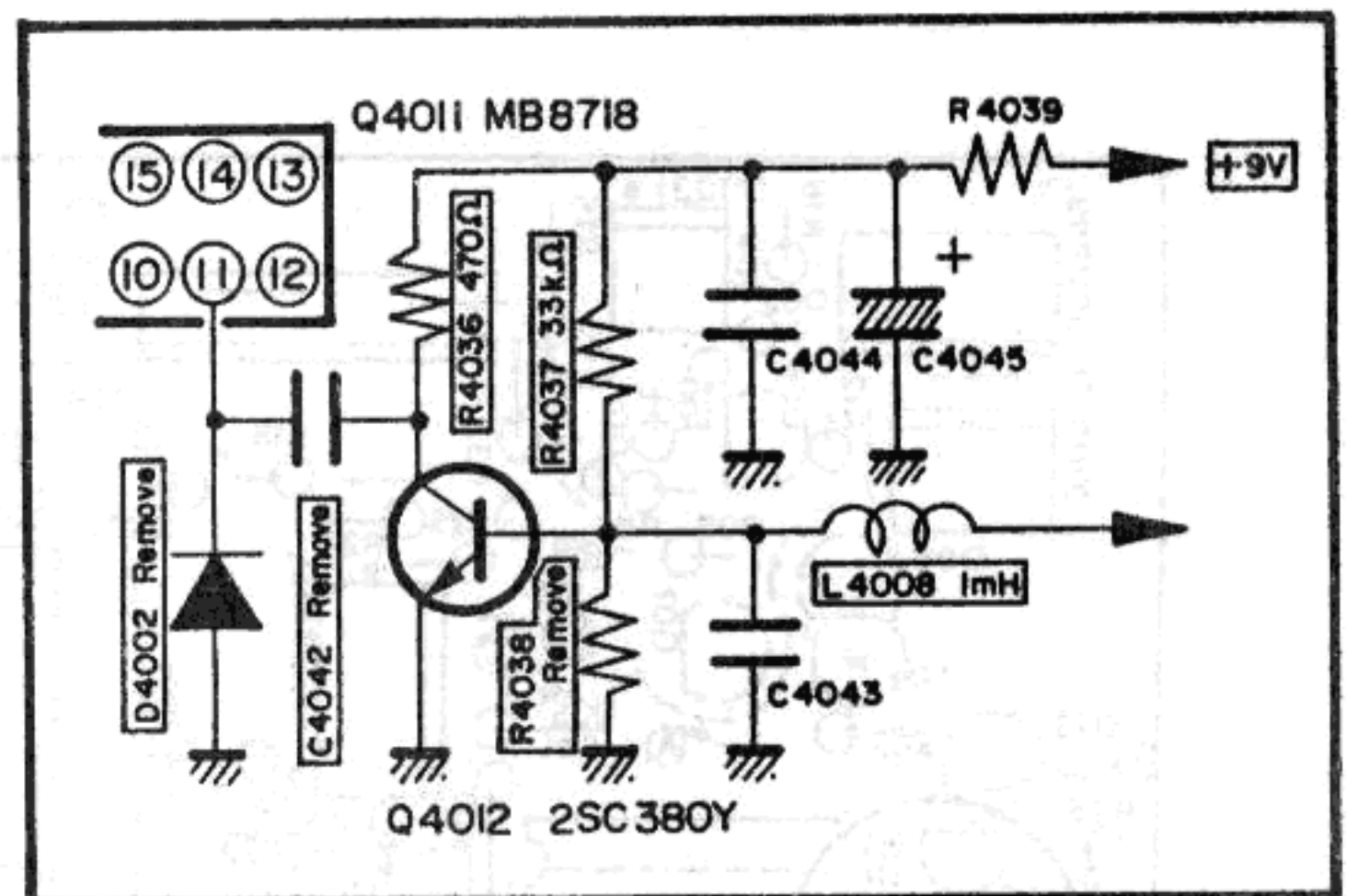
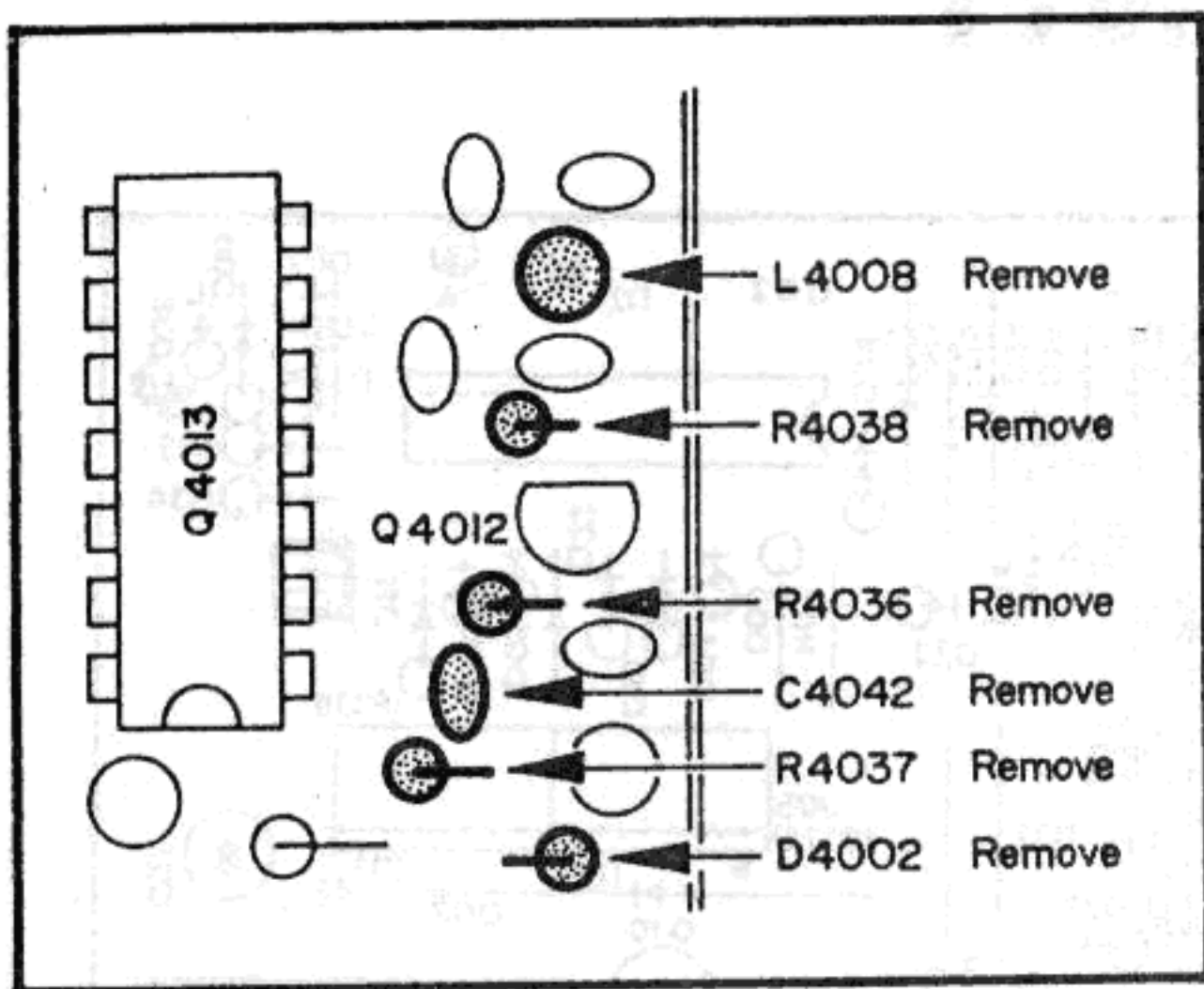

ERRATA FOR THE FT-980 TECHNICAL SUPPLEMENT

The following corrections apply to the first printing of the FT-980 technical supplement

RF Unit (page 8)

Add type 1SS53 (general purpose silicon) diode D_{1096} between the common anodes of the diodes connected to J_{1016} and pin 10 of Q_{1028} . The cathode of the new diode connects to Q_{1028} . Install on the solder side of the board, and use plastic insulating sleeves on each lead of the diode.

VFO Unit (page 9)

Remove resistors R_{7067} and R_{7093} .

PLL/VCO Unit (pages 10-12)

On the solder side of the board, cut the indicated track on the copper pattern in the area between Q_{4011} and Q_{4013} , and install the two jumpers as indicated in the figures on page 10.

Referring to page 11, remove resistors R_{4036} , R_{4037} and R_{4038} , capacitor C_{4042} , and diode D_{4002} and inductor L_{4008} . Replace R_{4036} with 1.5 kilohms in the same location as the original part. Replace R_{4037} with 100 kilohms, but install one lead in the hole originally used for the nearest lead of C_{4042} (removed), as illustrated. Replace L_{4008} with 390 μ H in the same location.

In the VCO enclosure on the PLL/VCO Unit (page 12), remove capacitors C_{4009} and C_{4011} , and replace both with the same value CH-type (instead of RH and UJ, removed). Make sure that these have not already been changed before removing: the CH types have black paint on the top, or are marked "CH". Also in the same area, replace C_{4006} with 4 pF CH, C_{4007} with 16 pF CH, and C_{4008} with 8 pF CH.

Add a silicon diode, a germanium diode and a 10 μ F, 16 WV tantalum capacitor on the solder side as indicated in the Figures on page 10.

FSK Unit

Remove capacitor C_{1802} , shown on page 12.

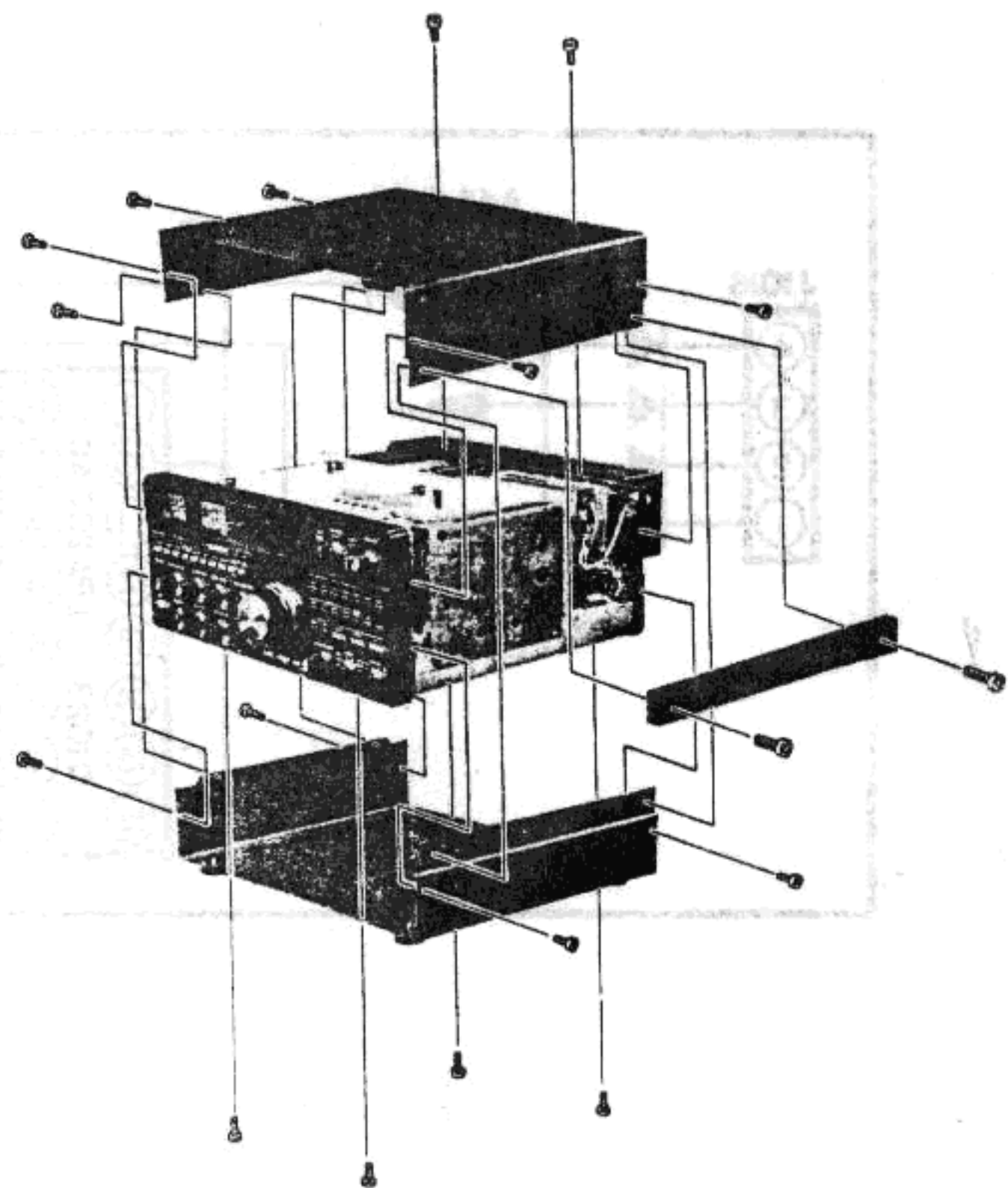

RF UNIT

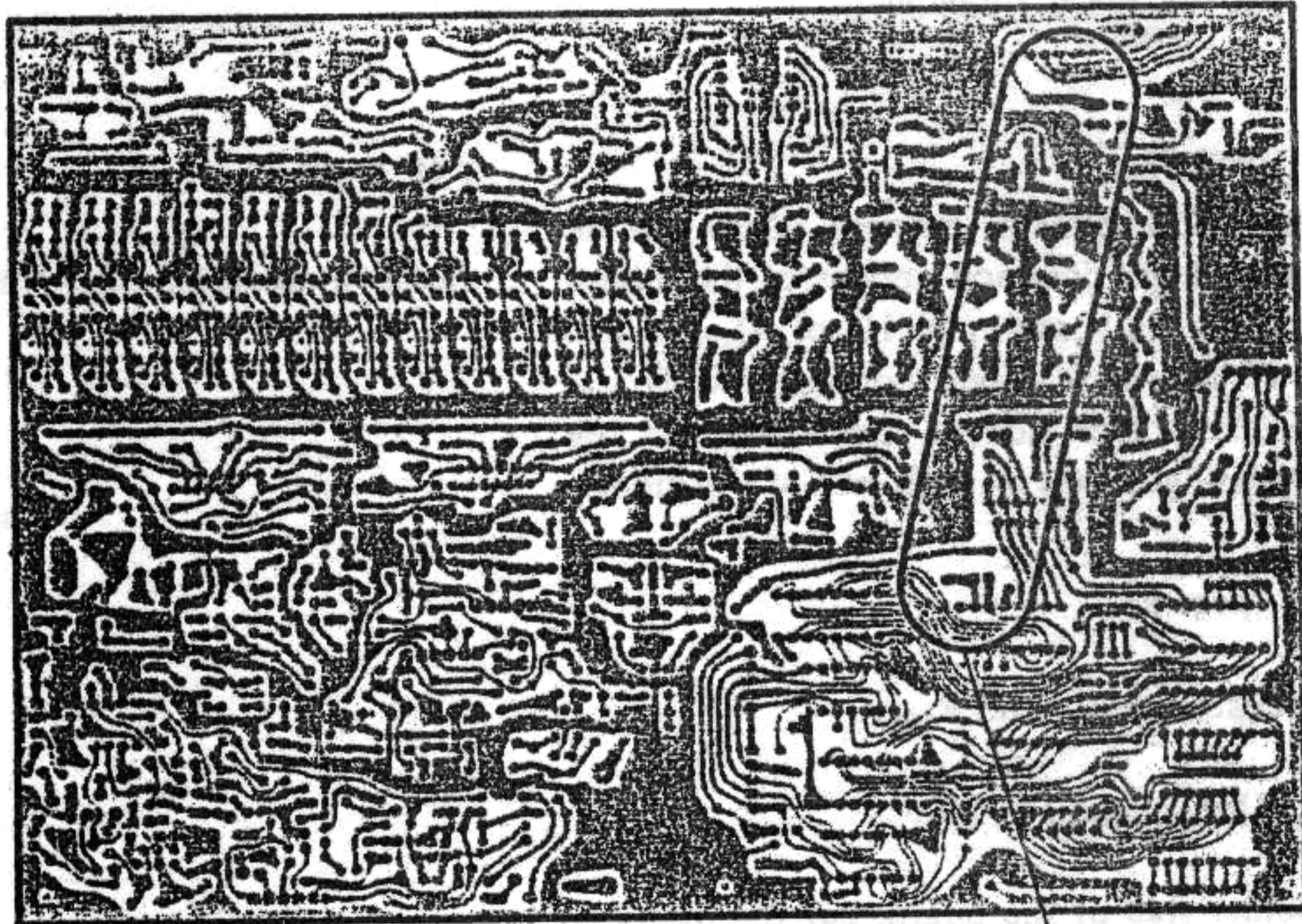

RF UNIT

Solder side

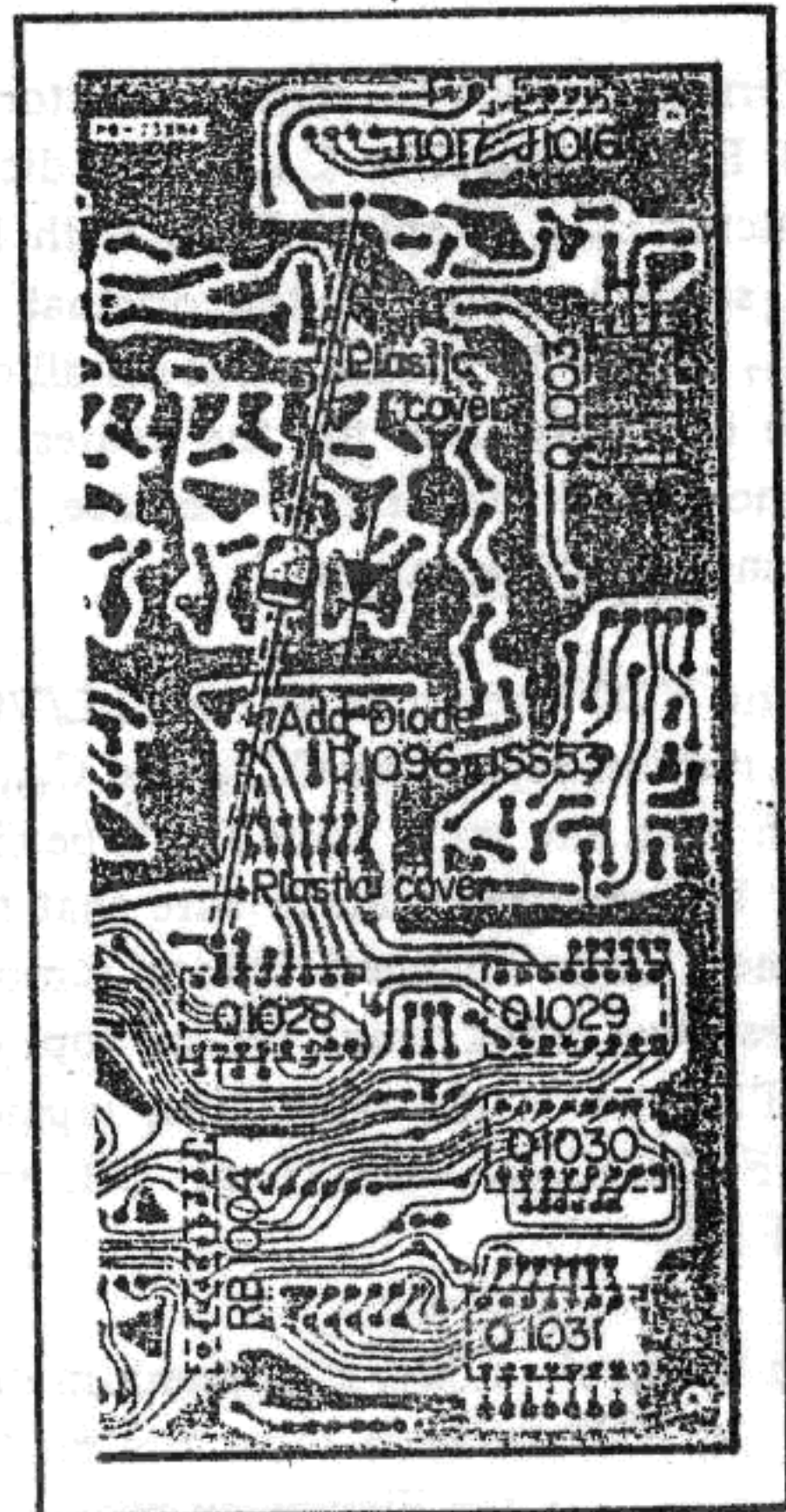
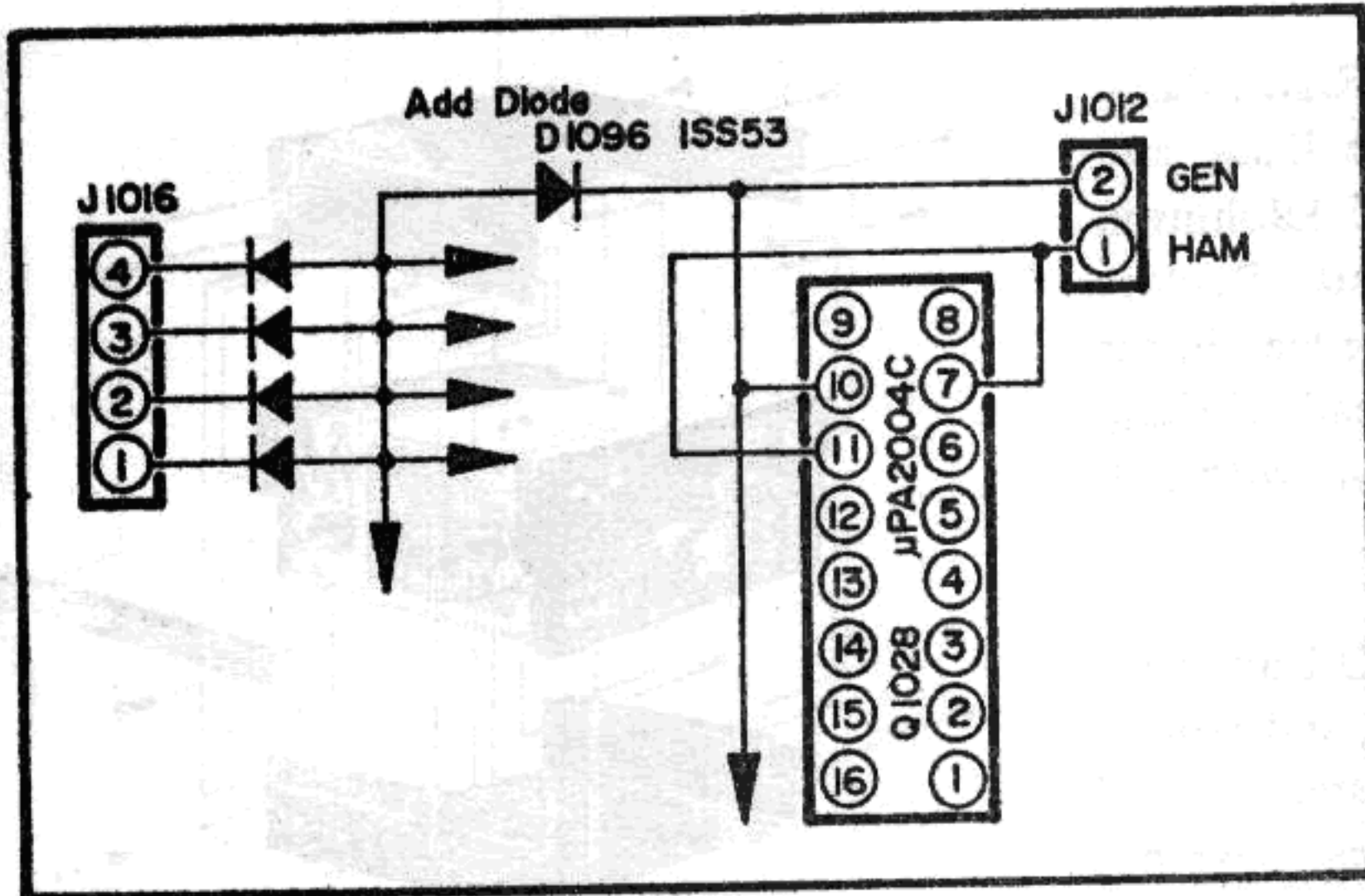

VFO UNIT

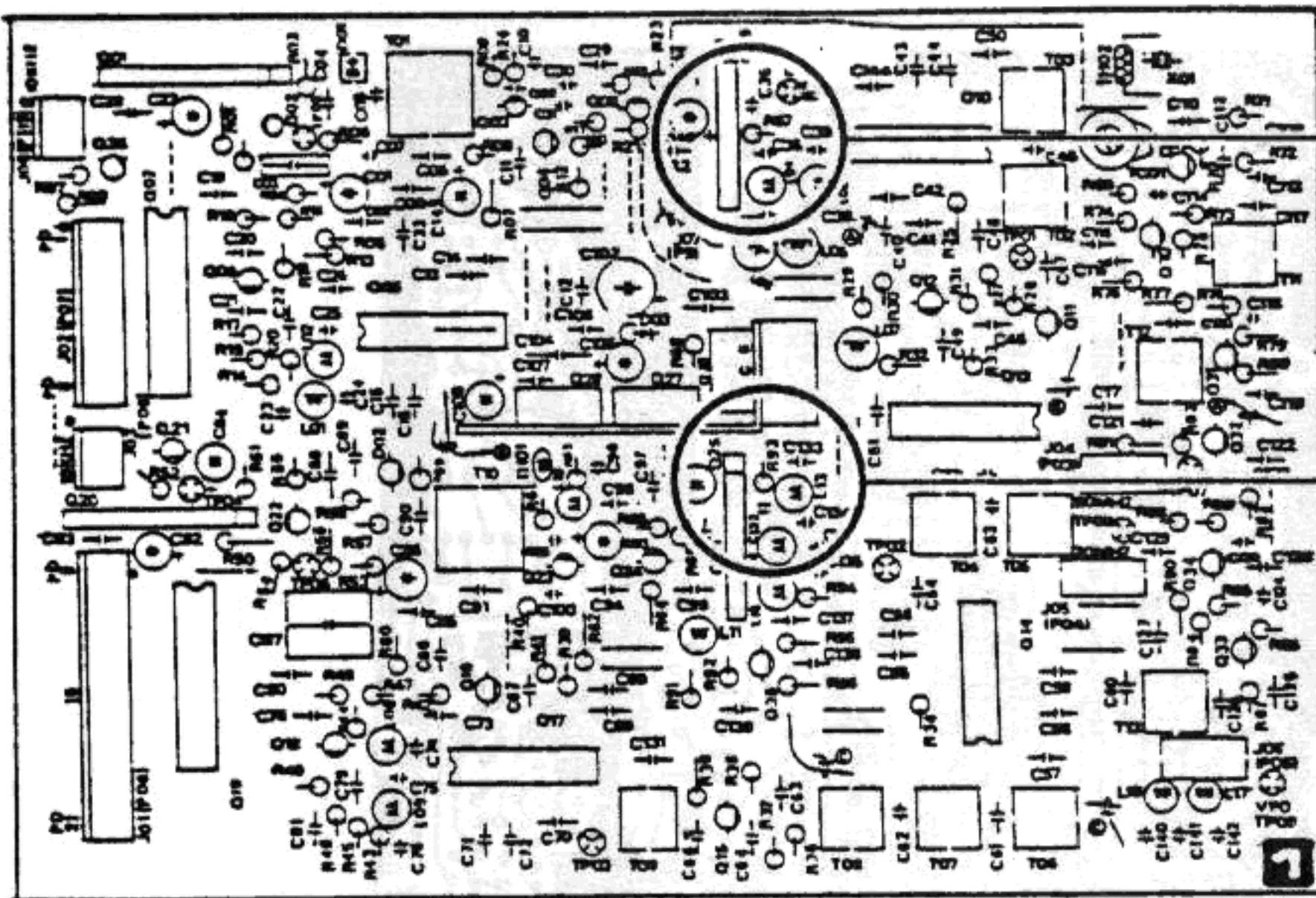
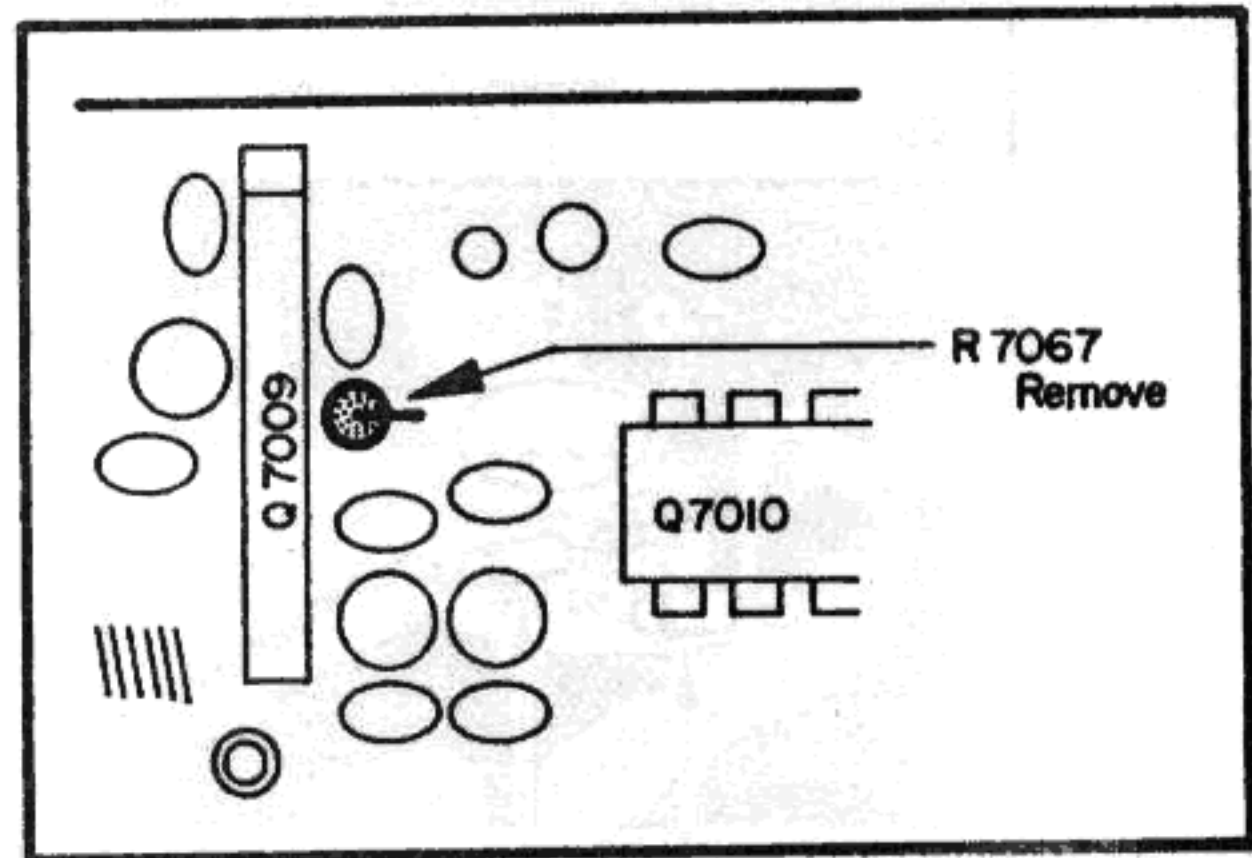

VFO UNIT

Component side

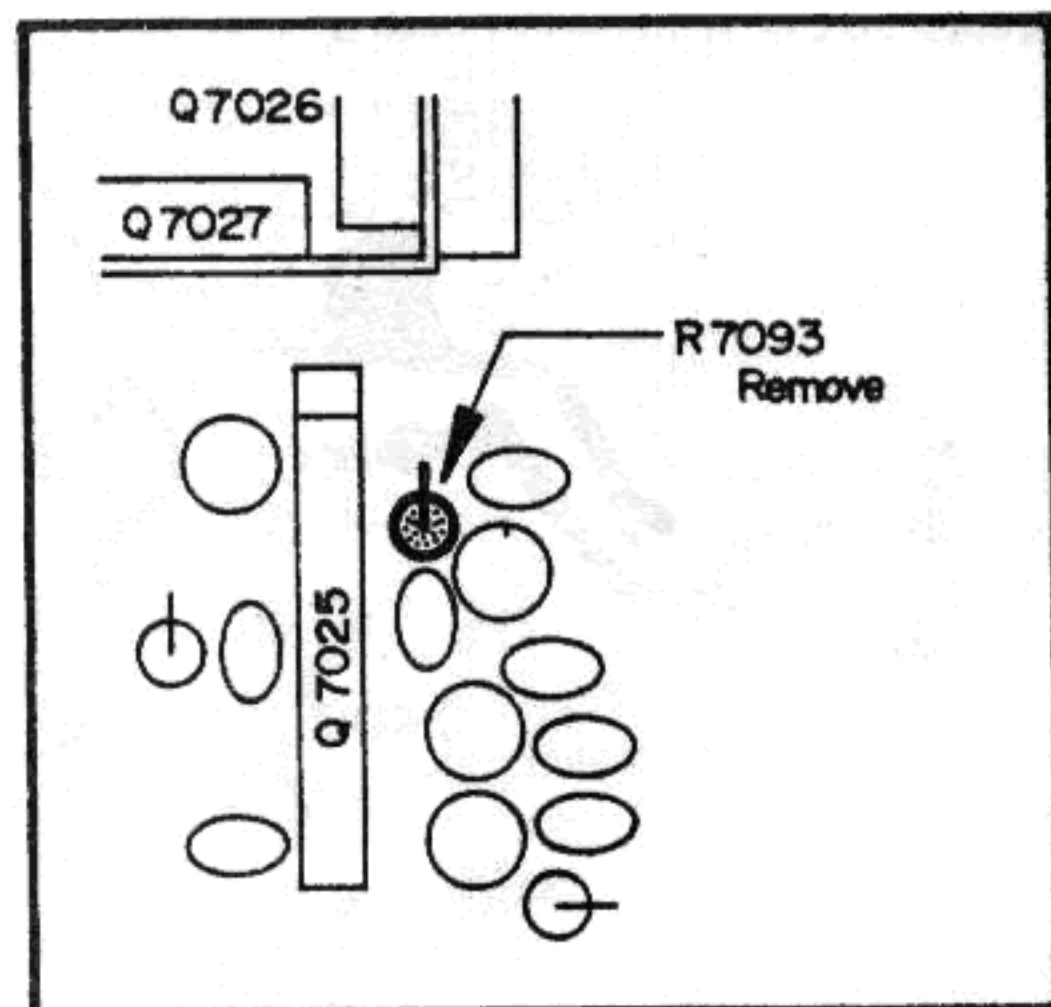

FT-980

OPTIONAL FILTER INSTALLATION

A. Required Parts (included w/kit)

This procedure is for installation of CW-W filter XF-8.9HC (Kit no. D2000011), and AM filter XF-8.9GA (Kit no. D2000012), and CW-N filter XF-455.8MCN (Kit no. D2000035); for any one or combination of these.

B. Modification Procedure

1. Disconnect the transceiver from the power source, and place it upside down on the work surface. Then remove the ten screws affixing the bottom cover, and the two screws affixing the carrying handle. Remove the cover and handle.
2. Locate the IF Unit, shown in the figure below, and remove the six screws marked with a star.
3. If installing the XF-8.9HC CW-W filter, refer to the figure below for the correct location on the board, and bolt the filter into place using the hardware supplied with the kit. Then solder the filter terminals into place on the solder side of the board. For this filter only, locate Jumper A as shown below, and change the connection of this jumper from the SSB to the CW terminal.

4. If installing the XF-8.9GA AM filter, refer to the figure below for the correct location on the board. Notice that there are three resistors in this filter location, which must be carefully unsoldered and removed before the filter is installed. Once the resistors have been removed, hold the filter snugly in place on the board while soldering the terminals on the solder side of the board.
5. For installation of the XF-455.8MCN CW-N filter, refer to the figure below for the correct location on the board. Hold the filter snugly in place on the board while soldering the terminals on the solder side of the board. Now refer to the figure below for the location of Jumper B, and change the connection of this jumper from the SSB to the CW position (but only when installing this filter).

Check the colors of the wires at pins 3 and 4 of P₇₁ (on J₂₀₀₁). Make sure that the white/red wire is at pin 3, and the white/orange wire is at pin 4. If not, reverse the connectors at these pins.

If the XF-455.8MCN CW-N filter is not being installed, and is not installed already, locate plug P₇₁ (on J₂₀₀₁), and reverse the wires in locations 3 and 4, so that the white/orange wire ends up at pin 3, and white/red at pin 4.

6. Replace the IF Unit and its six screws, making sure that no wires are stressed or pinched in the process. Then replace the bottom cover and its ten screws, followed by the carrying handle and its two screws.

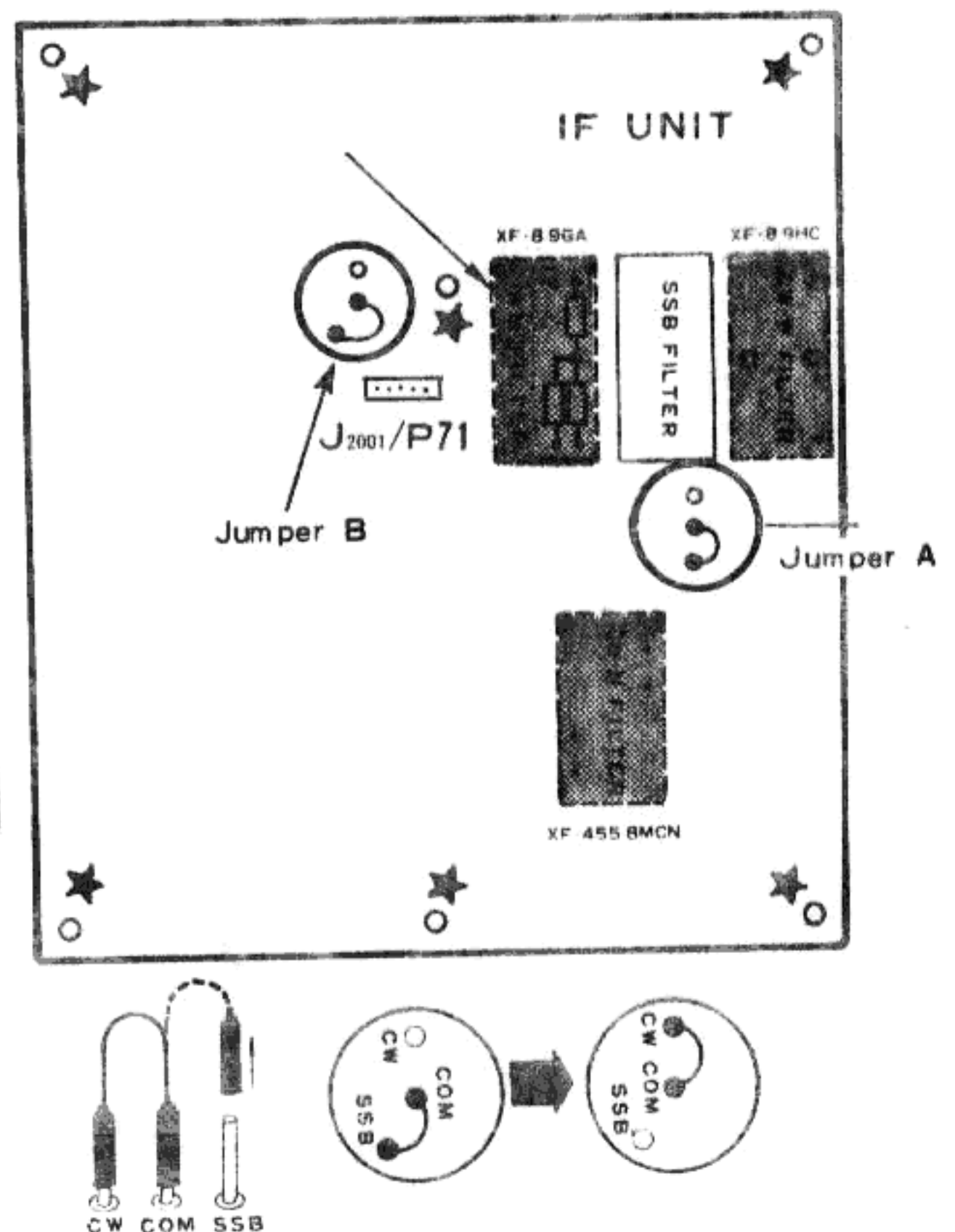
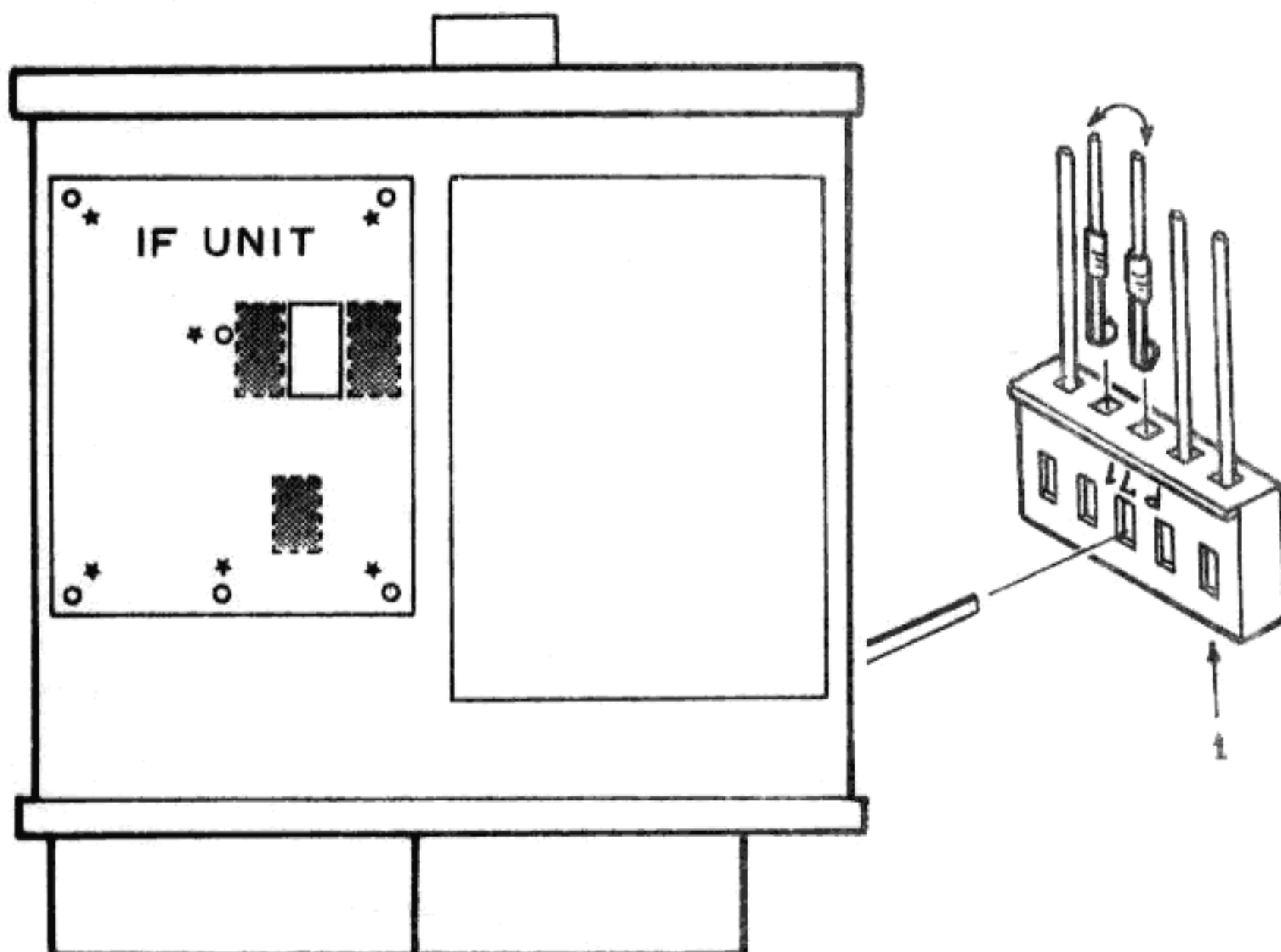

IMPORTANT NOTICE

To enable the FT-980 to operate full break-in with a linear amplifier designed for this purpose a small, high-speed relay is used in the T/R relay control circuit for the linear amplifier. Because this relay is small, certain precautions must be taken when connecting any linear amplifier.

First, make absolutely certain that a Back Pulse Cancelling Diode is installed across the coil of the T/R Relay in your linear amplifier. If such a diode is not installed, use the diode supplied with the FT-980, and install as shown in Figure 1.

Check the amount of current required to operate the T/R relay in the linear. If less than 200mA, the T/R control line can be connected directly to the TX GND and GND pins on the ACC-2 jack.

If the T/R relay in the linear requires more than 200mA, use a separate 12V DC relay and transistor between the linear and the ACC-1 jack, as shown in Figure 2. Make sure the coil of the added relay requires less than 200mA, and that the contacts are rated for a higher current than that required by the T/R relay in your linear.

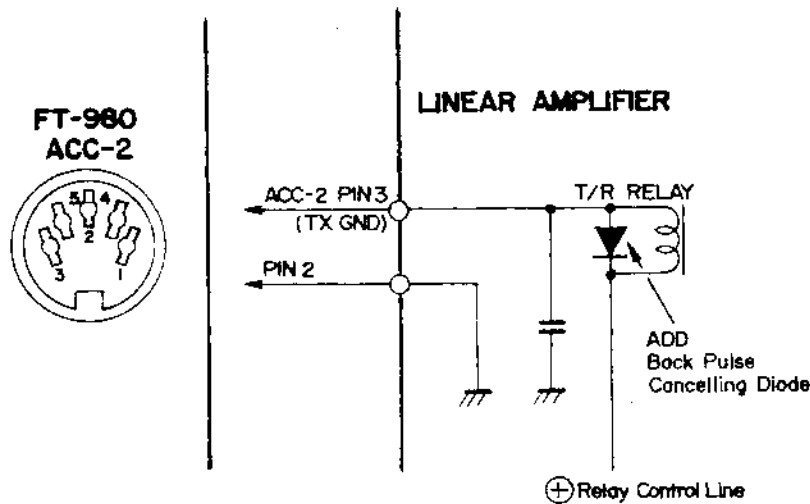

Figure 1

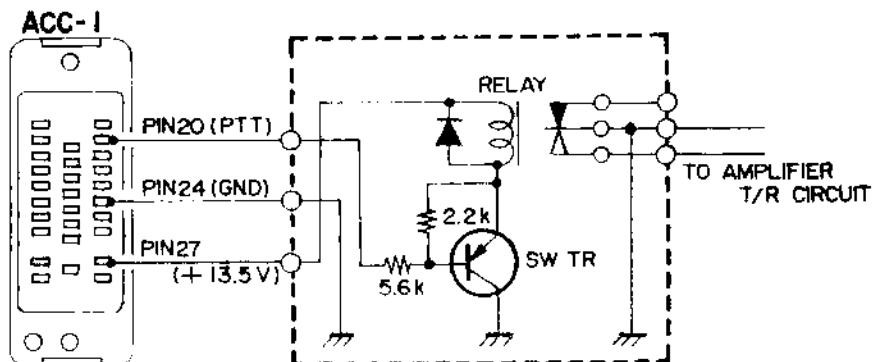

Figure 2

CAUTION

When a linear amplifier is used with the FT-980, check the current required to control the T/R relay in the linear amplifier. If less than 200 mA, the T/R control line can be directly connected to TX GND and GND on ACC-2 jack. However, also be sure that a BACK PULSE cancelling diode is installed across the T/R relay in your linear amplifier. If this diode is not present, install a general purpose rectifier diode as shown in Figure 1.

When the required T/R relay control is higher than 200 mA, the T/R control line from the linear amplifier must not be connected directly to the ACC-2 jack, but an extra relay box must be used to avoid damage to the T/R relay in the FT-980. Refer to Figure 2, and make the relay box for the interconnection. This relay box is not available from Yaesu.

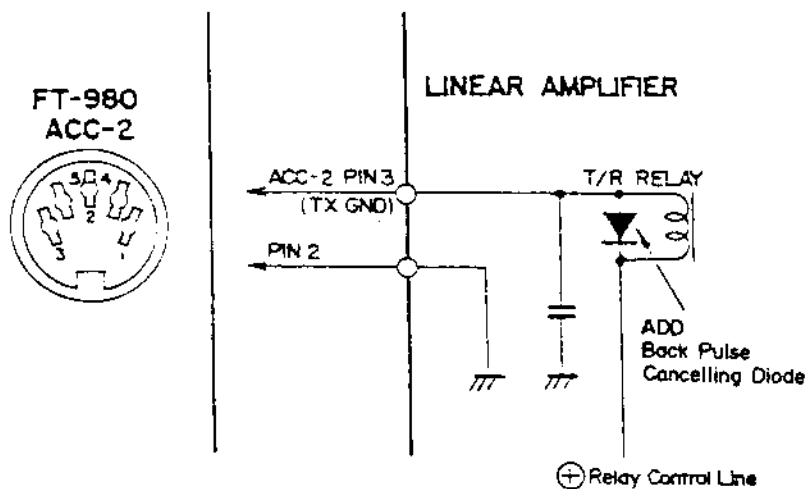

Figure 1

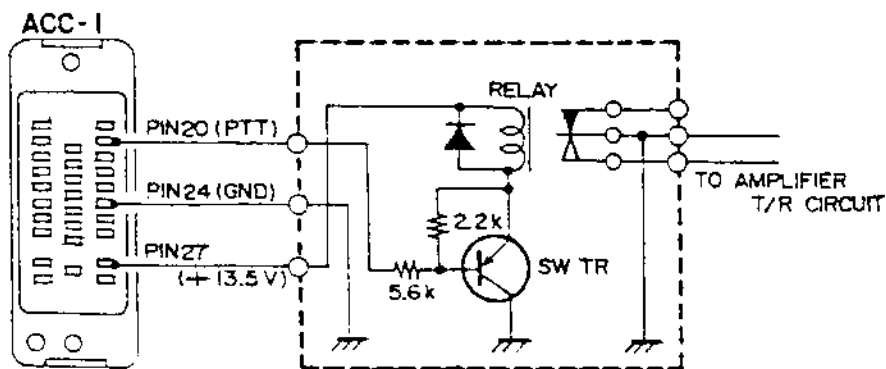

Figure 2